

**NEW HIERARCHIC THEORY OF WATER AND ITS ROLE IN BIOSYSTEMS.
BIVACUUM MEDIATED TIME EFFECTS, ELECTROMAGNETIC,
GRAVITATIONAL & MENTAL INTERACTIONS**

ALEX KAIVARAINEN

University of Turku,
Vesilinnantie 5, FIN-20014, Turku, Finland
H2o@karelia.ru
<http://www.karelia.ru/~alexk>

CONTENTS

SUMMARY

1. New Hierarchic Theory of Condensed Matter and its
Computerized Verification on Examples of Water & Ice
 - 1.1 **Basic notions and definitions of Hierarchic theory of matter**
 - 1.2 **Total Internal Energy of Condensed Matter**
 - 1.3 **Quantitative verification of Hierarchic theory
on examples of ice and water**
 - 1.3.1. *The coincidence of theoretical and experimental data for ice structure stability*
 - 1.3.2. *The coincidence of theoretical and experimental heat capacity of ice and water*
 - 1.3.3. *New State Equation for Condensed Matter*
 - 1.3.4. *Coincidence between calculated and experimental vapor pressure for ice and water*
 - 1.3.5. *Coincidence between calculated and experimental surface tension*
 - 1.3.6. *Coincidence between calculated and experimental thermal conductivity*
 - 1.4 **New Optoacoustic Device, Based on Hierarchic Theory:
Comprehensive Analyzer of Matter Properties (CAMP)**
2. Water as a Regulating Factor of Biopolymers
Properties and Evolution
 2. **Water as a Regulating Factor of Biopolymers
Properties and Evolution**
 - 2.1 **Role of water in dynamics of proteins**
 - 2.2 **The role of water in mechanism of protein-ligand specific complex formation
and signal transmission between domains and subunits**
 - 2.3 **The role of water in spatial parameters of proteins**
3. Multi-Fractional Model of Interfacial Water Structure.
Its Contribution to Morphogenetic Field
 - 3.1 **Possible role of interfacial water near cell's microfilaments in
morphogenetic field formation**
 - 3.2 **Infrared Laser and Ultrasound Radiation Based Cancer Cells
Selective Desintegrator**
4. Hierarchic Model of Consciousness:
From Molecular Bose Condensation to Synaptic Reorganization
 - 4.1 **Properties of Actin Filaments, Microtubules and Internal Water**
 - 4.2 **Stages of Hierarchic Model of Consciousness (HMC)**
 - 4.3 **The entropy-driven information processing**
 - 4.4 **Audio/Video Signals Skin Transmitter, Based on HMC**
5. Unified Model of Bivacuum, Duality of Matter and Fields,
as a Background of Psi-phenomena
 - 5.1 **Creation of sub-elementary particles & antiparticles**
 - 5.2 **Formation of elementary particles from sub-elementary particles**
 - 5.3 **Two Conservation Rules for Bivacuum Fermions (BVF¹) and sub-Elementary Particles**

(F_{\uparrow}^{\pm}) ,

as a Mass, Magnetic and Electric Dipoles of Bivacuum

5.4 The Relation Between the External and Internal Parameters of Elementary Particles

5.5 Duality, as a Result of Quantum Beats Between the Actual and Complementary States of Sub-elementary Particles, Forming the Elementary Particles

5.6 Quantum Roots of Golden Mean (GM)

5.7. Compensation principle of Bivacuum symmetry shifts, as a new explanation of fields, generated by elementary particles

5.8 Different presentations of the local energy contributions, related to spin field, electric and gravitational potentials at Golden mean conditions

5.9 Interrelation between the spin field, electromagnetic and gravitational fields energies and their space curvatures at Golden mean conditions

5.10 Curvature of Bivacuum domains of nonlocality

5.11 Neutrino and Antineutrino in Unified Model

5.12 Harmonization energy (HaE) and force (HaF) of Bivacuum, as a background of Time & Principle of Least Action

6 Possible mechanism of entanglement in microscopic and macroscopic systems

6.1 Quantum entanglement between coherent elementary particles

6.2. The mechanism of quantum entanglement in macroscopic systems

7. Bivacuum mediated Mind-Matter and Mind-Mind Interaction.

Virtual Replicas of Matter and Temporal effects

7.1 Explanation of Bivacuum mediated genetic information exchange between distant cells and different organisms

7.2 The examples of Virtual Channel (VC) action between Sender [S] (psychic) and targets [R]: physical fields and matter

7.3 The data, pointing to biological/biochemical aspects of Virtual Channel (VC) between Sender and receiver action

7.4 The physical basis for individual memory and sharing of mental images in remote viewing (RV) and telepathy

7.5 Temporal effects in evolution of Virtual Replicas

8 Experimental evidence in proof of Unified Model (UM)

8.1 Experimental confirmation of our theory of Bivacuum-mediated Mind-Matter Interaction

8.2 Imitation of Mind-Matter interaction by macroscopic flicker noise or macroscopic fluctuations

8.3 Experimental data, pointing that dissipation processes change the properties of Virtual replica (VR) of matter - [Sender] and interaction between [Sender] and [Receiver]

8.4 Possible theoretical background of S. Shnoll "Macroscopic fluctuations"

8.5 The life-times of Virtual Replicas (phantom effects)

8.6 The Superfluous Energy of Bivacuum and the Ways of its Regulation

8.7 Generation of unstable groups of coherent photons, electrons and positrons by fields, shifting Bivacuum fermions (dipoles) symmetry

8.8 The experimental program for verification of the proposed fundamental Bivacuum - Mediated Interaction (BMI)

9. Conclusion

10 Abbreviations and Definitions, Introduced in Unified Model of Matter - Fields Duality & Bivacuum Mediated Interactions

REFERENCES

SUMMARY

This paper contains few interrelated parts. The short version of new quantum Hierarchic theory, general for solids and liquids, created by the author is presented. Condensed matter in this theory is considered as a system of 3D standing waves (collective excitations) of different nature: thermal de Broglie waves (waves B), IR photons, related to intermolecular oscillations and thermal phonons (acoustic waves). Theory is verified by computer simulations on examples of pure water and ice, using special computer program (copyright 1997, Kaivarainen) yielding about 400 physical parameters, most of them hidden for direct experiment. The idea of new optoacoustic device with huge informational potential: Comprehensive Analyzer of Matter Properties (CAMP) with its various configurations and applications, based on Hierarchic theory is presented. The full version of this part of paper is on-line <http://arXiv.org/abs/physics/0102086>. Good correlation between simulated parameters of water and proteins dynamic structure points to crucial role of water in biopolymers evolution.

The idea of Infrared laser and ultrasound radiation induced cancer cells selective desintegrator, based on *biophysical* mechanism of cancer emergence, has been proposed.

It is shown, that multi-fractional model of interfacial water structure, introduced by author, can be responsible for some of morphogenetic field properties, related to alternating water activity. Computer simulations point, that coherent water clusters could be in state of mesoscopic molecular Bose condensation (mBC) even at physiological temperatures. The coherent IR radiation of such kind of enlarged water clusters in microtubules is supposed to be responsible for exchange interaction between microtubules of distant neurons, stimulating [gel-sol] transitions in neurons bodies, their volume and shape pulsation, and synaptic reorganization. It is a part of elementary act of consciousness (quantum Mind) worked out. The principle of Audio/Video Signals Skin Transmitter, Based on our Hierarchic model of consciousness, is suggested.

The Unified Model (UM) of Bivacuum, corpuscle [C] -wave [W] duality, electromagnetic and gravitational fields has been developed. Bivacuum is considered as the infinitive continuum, formed by the mass, electric and magnetic dipoles (Bivacuum fermions). Sub-elementary particles/antiparticles are the result of stable Bivacuum fermions symmetry shift, determined by resonant energy exchange interaction with Bivacuum. The triplets of sub-elementary particles and sub-elementary antiparticles and their combinations form the elementary particles. The [C \rightleftharpoons W] pulsation of sub-elementary particles are accompanied by emission - absorption of cumulative virtual clouds (CVC), formed by subquantum particles. The *irreversible* parts of CVC energy, determined by translational (longitudinal and transversal) contributions to kinetic energy of elementary particles, are responsible for electromagnetic and gravitational fields creation. Perturbation of Bivacuum properties, induced by [C \rightleftharpoons W] pulsation of particles, composing matter, we named *Virtual Replica* (VR) of matter. The massless nonlocal wave-guide (channel) between Sender [S] and Receiver [R] is formed by virtual spin waves (VirSW) of Bivacuum. The VirSW with properties of Nambu-Goldstone collective modes, are excited by the angular moment (spin) of *reversible* part of CVC energy (rotational), related to the rest mass of particles. The internal magnetic field and refraction index inside the virtual wave-guide (VirWG) are bigger, than the external ones, providing spatially directed exchange of virtual photons (energy) and spin state (information) between [S] and [R]. The macroscopic entanglement between [S] and [R] is a consequence of three factors: Harmonization force (HaF) of Bivacuum, realization of Principle of least action and modulation of virtual channels between [S] and [R] by nonlocal flicker noise. This flicker noise may have the same nature, as macroscopic fluctuations, discovered by S. Shnoll (1954-2003). In accordance to our theory, this noise can be a result of interference and quantum beats between nonlocal VirSW and Virtual Pressure Waves (VPW $^{\pm}$), activated in Bivacuum by [C \rightleftharpoons W] pulsation of elementary particles of [Sender] (Sun) and [Receiver] (different test systems). These two kinds of virtual waves form the virtual channels between [S] and [R]. The character of macroscopic fluctuations, providing the channels-mediated interaction, is dependent on properties of Virtual Replica of [S] - (Sun, perturbed by interaction with planets of Solar system) and Virtual Replica of [R] - (test systems on the Earth, perturbed by interaction with Moon). The time-dependent macroscopic fluctuations spectrums are dependent also on the relative position of Sun [S] and test-systems [R] and on the distance between them, i.e. on the Earth rotation (local time) and position of the Earth on the elliptic orbit around the Sun (month of the year). It is because the effects of beats and interference between the virtual waves, excited by [S] and [R] in Bivacuum, ability to form standing waves, are the function of the distance between them.

It is shown, that the pace of time:

$$\begin{aligned} \delta t/t &= -\delta(E_E + E_G)/(E_E + E_G) = \\ &= d \ln t = -d \ln(E_E + E_G) \end{aligned}$$

(real and virtual) is determined by the relative variations of the electromagnetic (E_E) and

gravitational (E_G) potentials of any closed system (real and virtual). The positive pace of virtual time, accompanied by decreasing of resulting ($E_E + E_G$), reflects the evolution/self-organization of complex VR_S of Solar system, including the VR_{Earth} of the Earth. It is possible, because the complex VR has a properties of active medium in state far from equilibrium. The resulting [Virtual Replica + Actual Matter and Fields] of the Universe due to possibility to self-organization and feedback reaction in system [$Matter \rightleftharpoons Fields \rightleftharpoons Virtual Replica$] acquire a functions of quantum supercomputer and Superconsciousness.

In combination with our model of Quantum Mind, these ideas were used for possible explanation of Bivacuum mediated ultraweak interaction, like mind-matter interaction, telepathy, remote vision, clairvoyance, etc. (see also <http://arXiv.org/abs/0207027> and <http://arXiv.org/abs/physics/0103031>).

The background of so called 'free energy of vacuum' are gravitational, electric and magnetic fields, shifting the symmetry of Bivacuum fermions (the mass, electric and magnetic dipoles) and making their resulting (differential) mass and charge nonzero. As a consequence, the interaction energy of the external gravitational, electric and magnetic fields with asymmetric Bivacuum dipoles - becomes nonzero also. The overunity devices (Brown, Bearden, Naudin, Searl and other) in their simplest versions use the uncompensated superfluous energy of asymmetric Bivacuum dipoles, generated by the Earth gravitation (in some sense, this energy is like the energy of waterfall). However, similar or opposite by sign symmetry shift of Bivacuum to that, induced by the Earth gravitation, can be reached as well by strong external magnetic (Searl, Bearden et al., Naudin) or electric (Brown) fields. The antigravitation effect can be achieved by the certain superposition of artificial gravitation, induced by centripetal acceleration, magnetic field of device, containing set of rotating magnets, with gravitational field of the Earth (Searl, Roshin and Godin). Such kinds of listed effects can be used for propulsion and as a source of pure energy.

1. New Hierarchic Theory of Condensed Matter and its Computerized Verification on Examples of Water & Ice

1.1 Basic notions and definitions of Hierarchic theory of matter

A quantum based new hierarchic quantitative theory, general for solids and liquids, has been developed.¹⁻³ It is assumed, that anharmonic oscillations of particles in any condensed matter lead to emergence of three-dimensional (3D) superposition of standing de Broglie waves of molecules, electromagnetic and acoustic waves. Consequently, any condensed matter could be considered as a 'gas' of 3D standing waves of corresponding nature. Our approach unifies and develops strongly the Einstein's and Debye's models and can be reduced to those after strong simplifications.

Collective excitations, like 3D standing de Broglie waves of molecules were analyzed, as a background of hierarchic model of condensed matter.

The most probable de Broglie wave (wave B) length is determined by the ratio of Plank constant to the most probable momentum of molecules, or by ratio of its most probable phase velocity to frequency. The waves B of molecules are related to their translations (tr) and librations (lb).

As the quantum dynamics of condensed matter is anharmonic and does not follow the classical Maxwell - Boltzman distribution, the real most probable de Broglie wave length can exceed the classical thermal de Broglie wave length and the distance between centers of molecules many times. *This makes possible the atomic and molecular mesoscopic Bose condensation (mBC) in solids and liquids at temperatures, below boiling point. It is one of the most important results of new theory, confirmed by computer simulations on examples of water and ice.*

Four strongly interrelated new types of quasiparticles (collective excitations) were introduced in our hierarchic model:

1. *Primary effectons (tr and lb)*, existing in "acoustic" (a) and "optic" (b) states represent the coherent clusters with resulting external momentum, equal to zero. *Secondary effectons* are the result of averaging of all effectons with nonzero external momentum, using Bose-Einstein

distribution;

2. *Convertons*, corresponding to interconversions between *tr* and *lb* types of the effectons (flickering clusters);

3. *Primary and secondary transitons* are the intermediate [$a \rightleftharpoons b$] transition states of the *tr* and *lb* primary and secondary effectons;

4. *Primary and secondary deformons* represent 3D superposition of IR electromagnetic and acoustic waves, correspondingly, activated by primary and secondary *transitons* and *convertons*.

Primary effectons (tr and lb) are formed by 3D superposition of the most probable standing de Broglie waves of the oscillating ions, atoms or molecules. The volume of effectons (*tr* and *lb*) may contain from less than one, to tens and even thousands of molecules. The first condition means validity of classical approximation in description of the subsystems of the effectons. The second one points to quantum properties of coherent clusters due to mesoscopic Bose condensation (mBC), in contrast to macroscopic BC, pertinent for superfluidity and superconductivity.

The liquids are semiclassical systems because their primary (*tr*) effectons contain less than one molecule and primary (*lb*) effectons - more than one molecule. The solids are quantum systems totally because both kind of their primary effectons (*tr* and *lb*) are mesoscopic molecular Bose condensates. These consequences of our theory are confirmed by computer calculations.

The 1st order [*gas* → *liquid*] transition is accompanied by strong degeneration of rotational (librational) degrees of freedom due to emergence of primary (*lb*) effectons (mBC) and [*liquid* → *solid*] transition - by degeneration of translational degrees of freedom due to Bose-condensation of primary (*tr*) effectons.

In the general case the effecton can be approximated by parallelepiped with edges determined by de Broglie waves length in three selected directions (1, 2, 3), related to symmetry of molecular dynamics. In the case of isotropic molecular motion the effectons' shape is approximated by cube. The edge-length of primary effectons (*tr* and *lb*) is considered as the "parameter of order" in our theory of phase transitions.

The in-phase oscillations of molecules in the effectons correspond to the effecton's (a) - acoustic state and the counterphase oscillations correspond to their (b) - optic state. States (a) and (b) of the effectons differ in potential energy only, however, their kinetic energies, momentums and spatial dimensions - are the same. The b-state of the effectons has a common feature with Frölich's polar mode. The ($a \rightarrow b$) or ($b \rightarrow a$) transition states of the *primary effectons* (*tr* and *lb*), defined as *primary transitons*, are accompanied by a change in molecule polarizability and dipole moment without density fluctuation. At this case these transitions lead to absorption or radiation of IR photons, respectively. Superposition (interception) of three internal standing IR photons of different directions (1,2,3), normal to each other - forms primary electromagnetic deformons (*tr* and *lb*).

On the other hand, the [$lb \rightleftharpoons tr$] *convertons* and *secondary transitons* are accompanied by the density fluctuations, leading to absorption or radiation of phonons. Superposition of three standing phonons, propagating in three directions (1,2,3), normal to each other, forms *secondary acoustic deformons (tr and lb)*.

Correlated collective excitations of primary and secondary effectons and deformons (*tr* and *lb*), localized in the volume of primary *tr* and *lb* electromagnetic deformons, lead to origination of *macroeffectons, macrotransitons and macrodeformons* (*tr* and *lb* respectively).

Macroconvertons are the result of simultaneous transitions [$a_{lb} \rightleftharpoons a_{tr}$] and [$b_{lb} \rightleftharpoons b_{tr}$] between the acoustic (a) and optic (b) modes of librational and translational effectons, accompanied by disassembly \rightleftharpoons assembly of coherent water clusters. This process is close to notion of 'flickering' clusters.

Correlated simultaneous excitations of *tr* and *lb* macroeffectons in the volume of superimposed *tr* and *lb* electromagnetic deformons lead to origination of *supereffectons*.

In turn, the simultaneous excitation of both: *tr* and *lb macrodeformons and macroconvertons* in the same volume means origination of *superdeformons*. Superdeformons are the biggest (cavitation) fluctuations, leading to microbubbles in liquids and to local defects in solids.

Total number of quasiparticles of condensed matter equal to $4!=24$, reflects all of possible combinations of the four basic ones [1-4], introduced above (Table 1). This set of collective excitations in the form of 3D standing waves of three types: thermal de Broglie waves, acoustic and electromagnetic ones - is proved to be able to explain virtually all the properties of all condensed matter.

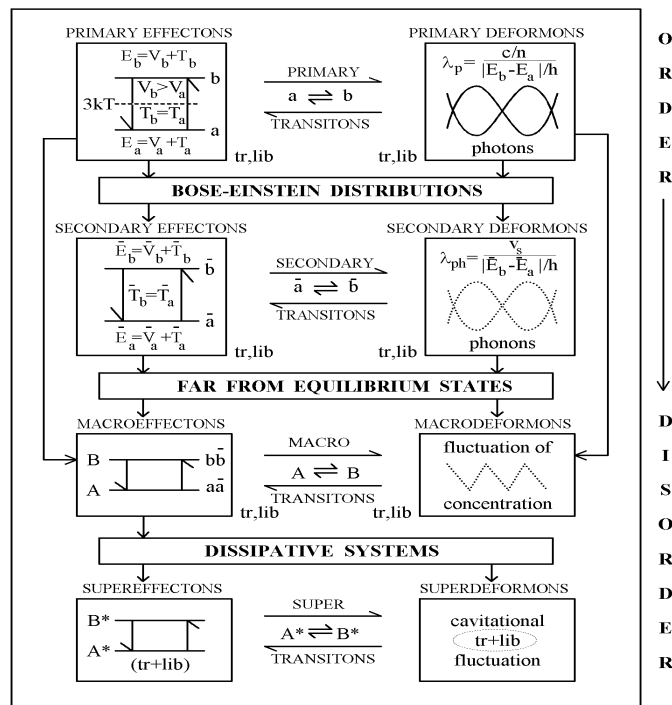

Table 1. Schematic representation of the 18 types of quasiparticles of condensed matter as a hierarchic dynamic system, based on the effectons, transitons and deformons. Total number of *quasiparticles*, introduced in Hierarchic concept is 24. Six collective excitations, related to *convertions*- interconversions between primary librational and translational effectons and their derivatives are not represented here for the end of simplicity.

The important positive feature of our hierarchic model of matter is that it does not need the semi-empirical intermolecular potentials for calculations, which are unavoidable in existing theories of many body systems. The potential energy of intermolecular interaction is involved indirectly in dimensions and stability of quasiparticles, introduced in our model.

The main formulae of theory are the same for liquids and solids and include following experimental parameters, which take into account their different properties: [1]- Positions of (tr) and (lb) bands in oscillatory spectra; [2]- Sound velocity; [3]- Density; [4]- Refraction index.

The knowledge of these four basic parameters at the same temperature and pressure makes it possible using our computer program, to evaluate more than 300 important characteristics of any condensed matter. Among them are such as: total internal energy, kinetic and potential energies, heat-capacity and thermal conductivity, surface tension, vapor pressure, viscosity, coefficient of self-diffusion, osmotic pressure, solvent activity, etc. Most of calculated parameters are hidden, i.e. inaccessible to direct experimental measurement.

This is the first theory able to predict all known experimental temperature anomalies for water and ice. The conformity between theory and experiment is good even without adjustable parameters. The hierarchic concept creates a bridge between micro- and macro- phenomena, dynamics and thermodynamics, liquids and solids in terms of quantum physics.

1.2 Total Internal Energy of Condensed Matter

The final formula for the total internal energy of (U_{tot}) of one mole of matter, leading from Hierarchic theory, considering condensed matter as a system of 3D standing waves is (see <http://arXiv.org/abs/physics/0102086>):

$$\begin{aligned}
U_{\text{tot}} = V_0 \frac{1}{Z} \sum_{tr,lb} & \left\{ \left[\begin{array}{c} n_{ef} \left(P_{ef}^a E_{ef}^a + P_{ef}^b E_{ef}^b + P_t E_t \right) \\ + n_d P_d E_d \end{array} \right] + \right. \\
& + \left[\bar{n}_{ef} \left(\bar{P}_{ef}^a \bar{E}_{ef}^a + \bar{P}_{ef}^b \bar{E}_{ef}^b + \bar{P}_t \bar{E}_t \right) + \bar{n}_d \bar{P}_d \bar{E}_d \right] + \\
& + \left[n_M \left(P_M^A E_M^A + P_M^B E_M^B \right) + n_D P_M^D E_M^D \right]_{tr,lb} + \\
& + V_0 \frac{1}{Z} \left[n_{\text{con}} \left(P_{ac} E_{ac} + P_{bc} E_{bc} + P_{cMt} E_{cMt} \right) + \right. \\
& + \left. \left(n_{cda} P_{ac} E_{ac} + n_{cdb} P_{bc} E_{bc} + n_{cMd} P_{cMd} E_{cMd} \right) \right] + \\
& + V_0 \frac{1}{Z} n_s \left[\left(P_S^{A*} E_S^{A*} + P_S^{B*} E_S^{B*} \right) + n_{D*} P_S^{D*} E_S^{D*} \right]
\end{aligned} \tag{1.1}$$

The meaning of the variables in formulae (1), necessary for the internal energy calculations, are presented in our paper (Kaivarainen, 2001). Total potential energy of one mole of condensed matter is defined by the difference between corresponding total internal energy and total kinetic energy: $V^{\text{tot}} = U^{\text{tot}} - T^{\text{tot}}$.

It is important to stress, that the same equations are valid for liquids and solids in our theory.

A lot of characteristics of condensed matter, composed from 24 quasiparticles - about 300, may be calculated, using hierarchic theory and CAMP computer program [copyright 1997, Kaivarainen]. For this end we need four basic input experimental parameters at the same temperature and pressure: 1) positions of translational and librational bands in middle/far IR spectrum of condensed matter; 2) sound velocity; 3) density or molar volume; 4) refraction index.

1.3 Quantitative verification of Hierarchic theory on examples of ice and water

1.3.1. The coincidence of theoretical and experimental data for ice structure stability

Our hierarchic theory makes it possible to calculate unprecedentedly big amount of parameters for liquids and solids. Part of them, accessible experimentally and taken from literature, are in good correspondence with CAMP - computer simulations.

For example, the calculated minimum of partition function for ice (Z) (Fig. 1a) corresponds to temperature of about -170°C . For the other hand, the interval from -198 to -173°C is known, indeed, as T- anomalies one due to the fact that the heat equilibrium of ice establishes very slowly in this range (Maeno, 1988). This fact is a consequence of the less probable ice structure (minimum value of partition function Z) near -170°C .

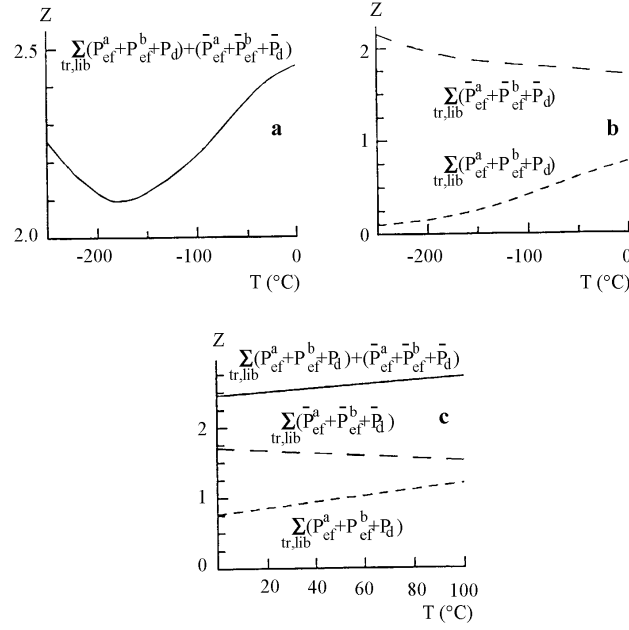

Figure 1.1 (a,b,c). Temperature dependences of the total partition function (Z) and contributions related to primary and secondary effectons and deformons for ice (a,b) and water (c).

1.3.2. The coincidence of theoretical and experimental heat capacity of ice and water

It follows from Fig. 2a that the mean theoretical value of heat capacity for ice in the interval from -75 to 0°C is equal to:

$$\bar{C}_p^{\text{ice}} = \frac{\Delta U_{\text{tot}}}{\Delta T} \approx 39 \text{ J/MK} = 9.3 \text{ cal/MK} \quad 1.2$$

For water within the whole range $\Delta T = 100^\circ\text{C}$, the theoretical change in the internal energy is: $\Delta U = 17 - 9.7 = 7.3 \text{ kJ/M}$ (Fig. 2b). This corresponds to mean value of heat capacity of water:

$$C_p^{\text{water}} = \frac{\Delta U_{\text{tot}}}{\Delta T} = 73 \text{ J/MK} = 17.5 \text{ cal/MK} \quad 1.3$$

These results of calculation agree well with the experimental mean values $C_p = 18 \text{ cal/MK}$ for water and $C_p = 9 \text{ cal/MK}$ for ice.⁴

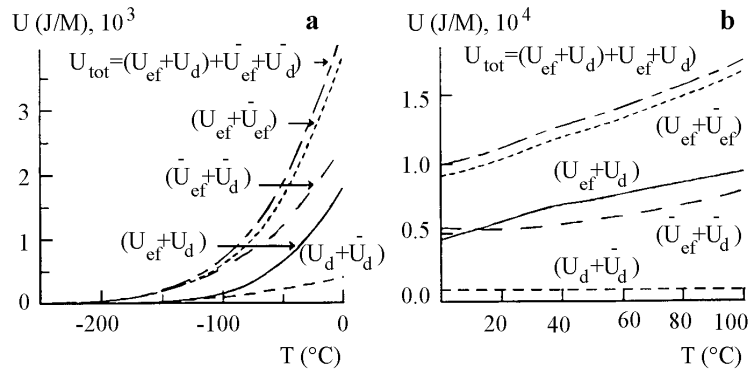

Figure 1.2. (a,b). Temperature dependences of the total internal energy (U_{tot}) and different contributions for ice (a) and water (b). Following contributions to U_{tot} are presented: $(U_{\text{ef}} + \bar{U}_{\text{ef}})$ is the contribution of primary and secondary effectons; $(U_d + \bar{U}_d)$ is the contribution of primary and secondary deformons; $(U_{\text{ef}} + U_d)$ is the contribution of primary effectons and deformons; $(\bar{U}_{\text{ef}} + \bar{U}_d)$ is the contribution of secondary effectons and deformons.

1.3.3. New State Equation for Condensed Matter

It was Van der Waals who choosed the first way more than a hundred years ago and derived the equation:

$$\left(P + \frac{a}{V^2}\right)(V - b) = RT \quad 1.4$$

where the attraction forces are accounted for by the amending term (a/V^2), while the repulsion forces and the effects of the excluded volume accounted for the term (b).

Equation (1.4) correctly describes changes in P,V and T related to liquid-gas transitions on the qualitative level. However, the quantitative analysis of (1.4) is approximate and needs the fitting parameters. The parameters (a) and (b) are not constant for the given substance and depend on temperature. Hence, the Van der Waals equation is only some approximation describing the state of a real gas.

Using our equation for the total internal energy of condensed matter (U_{tot}), we can present state equation in a more general form than (1.4). For this end we introduce the notions of *internal pressure* (P_{in}), including *all type of interactions* between particles of matter and excluded molar volume (V_{exc}):

$$V_{\text{exc}} = \frac{4}{3}\pi\alpha^*N_0 = V_0\left(\frac{n^2 - 1}{n^2}\right) \quad 1.5$$

where α^* is the acting polarizability of molecules in condensed matter; N_0 is Avogadro number, and V_0 is molar volume.

The new general state equation can be expressed as:

$$P_{\text{tot}}V_{\text{fr}} = (P_{\text{ext}} + P_{\text{in}})(V_0 - V_{\text{exc}}) = U_{\text{ef}} \quad 1.6$$

where: $U_{\text{ef}} = U_{\text{tot}}(1 + V/T_{\text{kin}}) = U_{\text{tot}}^2/T_{\text{kin}}$ is the effective internal energy and:

$$(1 + V/T_{\text{kin}}) = U_{\text{tot}}/T_{\text{kin}} = S^{-1} \quad 1.7$$

is the reciprocal value of the total structural factor; $P_{\text{tot}} = P_{\text{ext}} + P_{\text{in}}$ is total pressure, P_{ext} and P_{in} are external and internal pressures; $V_{\text{fr}} = V_0 - V_{\text{exc}} = V_0/n^2$ (see eq.1.5) is a free molar volume; $U_{\text{tot}} = V + T_{\text{kin}}$ is the total internal energy, V and T_{kin} are total potential and kinetic energies of one mole of matter.

For the limit case of ideal gas, when $P_{\text{in}} = 0$; $V_{\text{exc}} = 0$; and the potential energy $V = 0$, we get from (1.6) the Clapeyrene - Mendelejev equation:

$$P_{\text{ext}}V_0 = T_{\text{kin}} = RT$$

One can use equation of state (1.6) for estimation of sum of *all types of internal matter interactions*, which determines the internal pressure P_{in} :

$$P_{\text{in}} = \frac{U_{\text{ef}}}{V_{\text{fr}}} - P_{\text{ext}} = \frac{n^2 U_{\text{tot}}^2}{V_0 T_{\text{kin}}} - P_{\text{ext}} \quad 1.8$$

where: the molar free volume: $V_{\text{fr}} = V_0 - V_{\text{exc}} = V_0/n^2$;
and the effective total energy: $U_{\text{ef}} = U_{\text{tot}}^2/T_{\text{kin}} = U_{\text{tot}}/S$; where $S = T_{\text{kin}}/U_{\text{tot}}$ is a total structural factor.

1.3.4. Coincidence between calculated and experimental vapor pressure for ice and water

There was not earlier the satisfactory quantitative theory for *vapor pressure* calculation.

Such a theory has been derived, using our notion of collective excitations: *superdeformons*, representing the biggest thermal fluctuations.^{2,3} The basic idea is that the external equilibrium vapor pressure is related to internal one (P_{in}^S) with coefficient determined by the probability of

cavitation fluctuations (superdeformons) in the **surface layer** of liquids or solids.

In other words due to excitation of superdeformons with probability (P_D^S), the internal pressure (P_{in}^S) in surface layers, determined by the total contributions of all intramolecular interactions turns to external one - vapor pressure (P_V). It is something like a compressed spring energy realization due to trigger switching off.

For taking into account the difference between the surface and bulk internal pressure (P_{in}) we introduce the semi-empirical surface pressure factor (q^S) as:

$$P_{in}^S = q^S P_{in} = q^S \left(\frac{n^2 U_{tot}}{V_0 S} - P_{ext} \right) \quad 1.9$$

where: P_{in} corresponds to eq.(1.8); $S = T_{kin}/U_{tot}$ is a total structure factor.

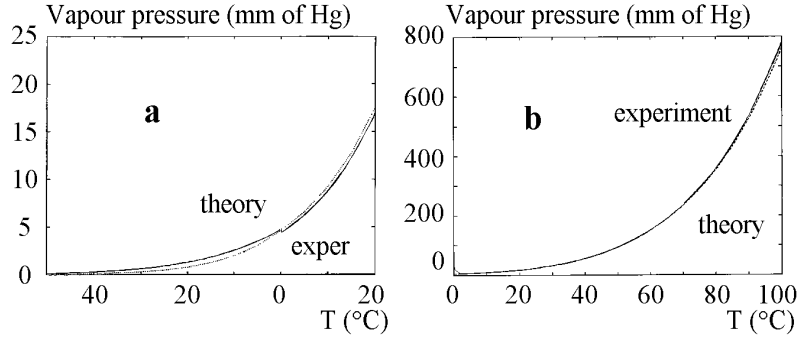

Figure. 1.3. a) Theoretical (—) and experimental (••) temperature dependences of vapor pressure (P_{vap}) for ice (a) and water (b), including phase transition region. The experimental data were taken from Handbook of Chem. & Phys. 67 ed., CRC press, 1986-1987.

Multiplying (1.9) to probability of superdeformons excitation we obtain for vapor pressure, resulting from evaporation or sublimation, the following formulae:

$$P_{vap} = P_{in}^S \cdot P_D^S = q^S \left(\frac{n^2 U_{tot}^2}{V_0 T_{kin}} - P_{ext} \right) \exp \left(-\frac{E_D^S}{kT} \right) \quad 1.10$$

where:

$$P_D^S = \exp \left(-\frac{E_D^S}{kT} \right) \quad 1.11$$

is a probability of superdeformons excitation (see eqs. 3.37, 3.32 and 3.33 from³).

The pressure surface factor (q^S) could be presented as:

$$q^S = P_{in}^S / P_{in}$$

Theoretical calculated temperature dependences of vapor pressure, described by (1.10) coincide very well with experimental ones for water at $q_{liq}^S = 3.1$ and for ice at $q_{sol}^S = 18$ (Fig. 1.3).

The almost five-times difference between q_{sol}^S and q_{liq}^S means that the *surface* properties of ice differ from *bulk* ones much more than for liquid water.

1.3.5. Coincidence between calculated and experimental surface tension

The resulting surface tension is introduced in our mesoscopic model as a sum:

$$\sigma = (\sigma_{tr} + \sigma_{lb}) \quad 1.12$$

where: σ_{tr} and σ_{lb} are translational and librational contributions to surface tension. Each of these components can be expressed using our mesoscopic state equation (1.6), taking into account the

difference between surface and bulk total energies (q^S), introduced in previous section:

$$\sigma_{tr} = \frac{1}{\frac{1}{\pi}(V_{lb_{ef}})_{tr,lb}^{2/3}} \left[\frac{q^S P_{tot}(P_{ef} V_{ef})_{tr,lb} - P_{tot}(P_{ef} V_{ef})_{tr,lb}}{(P_{ef} + P_t)_{tr} + (P_{ef} + P_t)_{lb} + (P_{con} + P_{cMt})} \right] \quad 1.13$$

where $(V_{ef})_{tr,lb}$ are volumes of primary tr and lib effectons, related to their concentration $(n_{ef})_{tr,lb}$ as:

$$(V_{ef})_{tr,lb} = (1/n_{ef})_{tr,lb};$$

$$r_{tr,lb} = \frac{1}{\pi} (V_{ef})_{tr,lb}^{2/3}$$

is an effective radius of the primary translational and librational effectons, localized on the surface of condensed matter; q^S is the surface factor, equal to that used in vapor pressure calculations; $[P_{tot} = P_{in} + P_{ext}]$ is a total pressure; $(P_{ef})_{tr,lb}$ is a total probability of primary effecton excitations in the (a) and (b) states:

$$(P_{ef})_{tr} = (P_{ef}^a + P_{ef}^b)_{tr}$$

$$(P_{ef})_{lb} = (P_{ef}^a + P_{ef}^b)_{lb}$$

$(P_t)_{tr}$ and $(P_t)_{lb}$ in (13) are the probabilities of corresponding transiton excitation;

$P_{con} = P_{ac} + P_{bc}$ is the sum of probabilities of [a] and [b] *convertons*; $P_{cMt} = P_{ac} P_{bc}$ is a probability of Macroconvertons excitation.

The eq. (1.13) contains the ratio:

$$(V_{ef}/V_{ef}^{2/3})_{tr,lb} = l_{tr,lb} \quad 1.14$$

where: $l_{tr} = (1/n_{ef})_{tr}^{1/3}$ and $l_{lb} = (1/n_{ef})_{lb}^{1/3}$ are the length of the ribs of the primary translational and librational effectons, approximated by cube.

The resulting surface tension can be presented as:

$$\sigma = \sigma_{tr} + \sigma_{lb} = \pi \frac{P_{tot}(q^S - 1) \left[(P_{ef})_{tr} l_{tr} + (P_{ef})_{lb} l_{lb} \right]}{(P_{ef} + P_t)_{tr} + (P_{ef} + P_t)_{lb} + (P_{con} + P_{cMt})} \quad 1.15$$

The results of computer calculations of σ (eq. 1.15) for water and experimental data are presented at Fig.1.4.

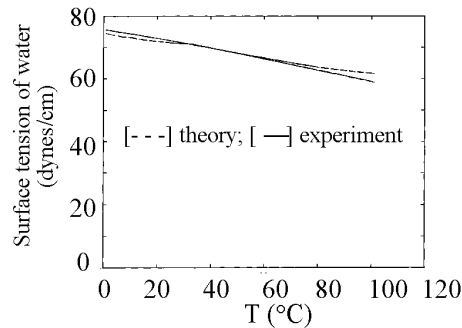

Figure 1.4. Experimental (—) and theoretical (---) temperature dependences of the surface tension for water. The experimental data were taken from Handbook of Chem. & Phys., 67 ed., CRC press, 1986-1987.

It is obvious, that the correspondence between theory and experiment is very good,

confirming in such a way the correctness of our model and Hierarchic concept in general.

1.3.6. Coincidence between calculated and experimental thermal conductivity

Thermal conductivity may be related to phonons, photons, free electrons, holes and [electron-hole] pairs movement. We will discuss here only the main type of thermal conductivity in condensed matter, related to phonons.

Hierarchic theory introduce two contributions to thermal conductivity: related to phonons, radiated by secondary effectons and forming *secondary* translational and librational deformons ($\kappa_{sd})_{tr,lb}$ and to phonons, radiated by *a* and *b* convertons [*tr/lb*], forming the convertons-induced deformons ($\kappa_{cd})_{ac,bc}$:

$$\kappa = (\kappa_{sd})_{tr,lb} + (\kappa_{cd})_{ac,bc} = \frac{1}{3} C_v v_s [(\Lambda_{sd})_{tr,lb} + (\Lambda_{cd})_{ac,bc}] \quad 1.16$$

where: free runs of secondary phonons (tr and lb) are represented as:

$$1/(\Lambda_{sd})_{tr,lb} = 1/(\Lambda_{tr}) + 1/(\Lambda_{lb}) = (\bar{v}_d)_{tr}/v_s + (\bar{v}_d)_{lb}/v_s$$

consequently:

$$1/(\Lambda_{sd})_{tr,lb} = \frac{v_s}{(\bar{v}_d)_{tr} + (\bar{v}_d)_{lb}} \quad 1.17$$

and free runs of convertons-induced phonons:

$$1/(\Lambda_{cd})_{ac,bc} = 1/(\Lambda_{ac}) + 1/(\Lambda_{bc}) = (v_{ac})/v_s + (v_{bc})/v_s$$

The heat capacity: $C_V = \partial U_{tot}/\partial T$ can be calculated also from our theory.

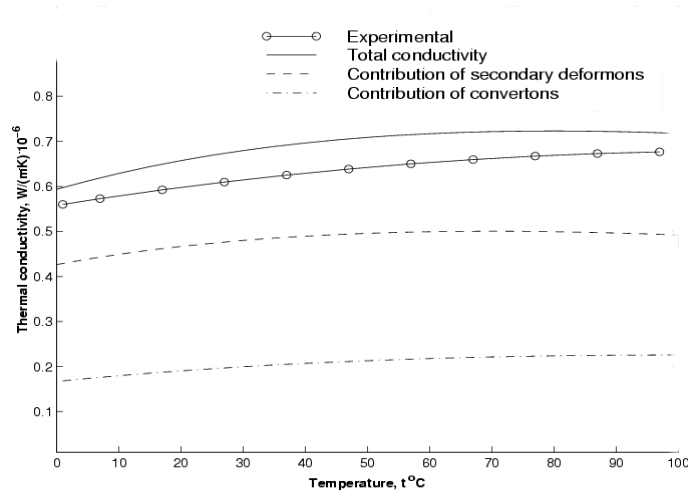

Figure 1.5. Temperature dependences of total thermal conductivity for water and contributions, related to acoustic deformons and [*lb/tr*]convertons. The experimental data were taken from Handbook of Chem. & Phys., 67 ed., CRC press, 1986-1987.

1.3.7. Coincidence between calculated and experimental viscosity for liquids and solids

The viscosity is determined by the energy dissipation as a result of medium (liquid or solid) structure deformation. Viscosity, corresponding to the shift deformation, is named *shear viscosity*. So-called *bulk viscosity* is related to deformation of volume parameters and corresponding dissipation. These types of viscosity have not the same values.

The new hierarchic theory of viscosity has been developed. The dissipation processes, related to ($A \rightleftharpoons B$)_{tr,lb} cycles of translational and librational macroeffectons and (a,b)-convertons excitations were analyzed.

In contrast to liquid state, the viscosity of solids is determined by the biggest fluctuations:

supereffectons and superdeformons, resulting from simultaneous excitations of translational and librational macroeffectons and macrodeformons in the same volume.³

The contributions of translational and librational macrodeformons to resulting viscosity are present in following way:

$$\eta_{tr,lb}^M = \left[\frac{E_D^M}{\Delta v_f^0} \tau^M \left(\frac{T_k}{U_{tot}} \right)^3 \right]_{tr,lb} \quad 1.18$$

where: (Δv_f^0) is the reduced fluctuating volume; the energy of macrodeformons: $[E_D^M = -kT(\ln P_D^M)]_{tr,lb}$.

The cycle-periods of the *tr* and *lb* macroeffectons has been introduced as:

$$[\tau^M = \tau_A + \tau_B + \tau_D]_{tr,lb} \quad 1.19$$

where: characteristic life-times of macroeffectons in A, B-states and that of transition state in the volume of primary electromagnetic deformons can be presented, correspondingly, as follows:

$$[\tau_A = (\tau_a \tau_{\bar{a}})^{1/2}]_{tr,lb} \quad \text{and} \quad [\tau_A = (\tau_a \tau_{\bar{a}})^{1/2}]_{tr,lb} \quad 1.20$$

$$[\tau_D = |(1/\tau_A) - (1/\tau_B)|^{-1}]_{tr,lb} \quad 1.21$$

Using (1.18 - 1.21) it is possible to calculate the contributions of $(A \rightleftharpoons B)$ cycles of translational and librational macroeffectons to viscosity separately.

The averaged contribution of Macroexcitations (*tr* and *lb*) in viscosity is:

$$\eta^M = \left[(\eta)_{tr}^M (\eta)_{lb}^M \right]^{1/2} \quad 1.22$$

The resulting theoretical viscosity (Fig. 1.6) was calculated as a sum of the averaged contributions of macrodeformons and convertons:

$$\eta = \eta^M + \eta_c \quad 1.23$$

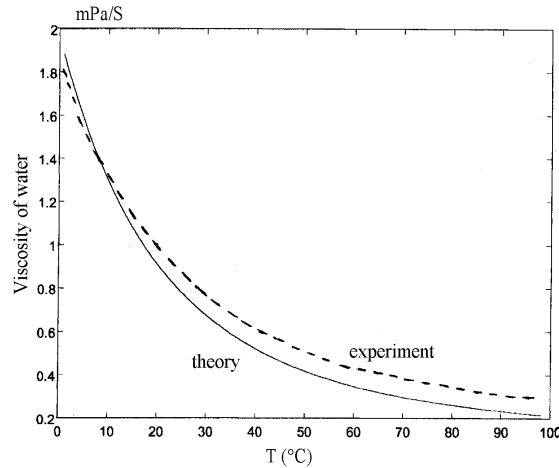

Figure 1.6. Theoretical and experimental temperature dependences of water viscosity. The experimental data were taken from Handbook of Chem. & Phys. 67 ed., CRC press, 1986-1987.

Like in the cases of thermal conductivity, viscosity and vapor pressure, the results of theoretical calculations of self-diffusion coefficient coincide well with experimental data for water in temperature interval $(0 - 100^\circ\text{C})$.³ The coefficient of self-diffusion in solids also may be evaluated using the CAMP computer program.

The important conclusion, leading from the examples presented above, is that as far the final results of calculations are in a good accordance with experiment, it means that a lot of intermediate parameters, hidden from direct experiment, characterizing the spatial and dynamic properties of number of collective excitations of condensed matter - also correctly describe the matter properties.

1.4 New Optoacoustic Device, Based on Hierarchic Theory: Comprehensive Analyzer of Matter Properties (CAMP)

The set of formulae obtained in our theory allows to calculate about 300 physical parameters of any condensed matter (liquid or solid). Most of them are hidden, i.e. inaccessible for direct experimental measurements.

Simulations evaluation of these parameters can be done using our computer program: CAMP (copyright 1997, Kaivarainen) and the following experimental methods:

1. Far-middle FT-IR or FT-Raman spectroscopy for determination the positions of translational or librational bands: $(50-2500) \text{ cm}^{-1}$; 2. Sound velocimetry; 3. Densitometry; 4. Refractometry.

Corresponding data may be obtained at the same temperature and pressure from the same sample (liquid or solid), located in more than one cell and from the same cell for study of nonequilibrium dynamics or kinetic processes.

This leads to idea of new optoacoustic device: Comprehensive Analyzer of Matter Properties (CAMP), which may provide a huge amount of data of any condensed system under study.

The most complicated and expensive component of CAMP is FT-IR or FT-Raman or Brillouin spectrometer for registration of spectra in far and middle IR region. The most sensitive parameter is sound velocity.

One of possible CAMP configuration (Table 2) includes special attachment to FT-IR spectrometer (Harrick Scientific Co.), making it possible registration of reflection spectra in far/middle IR region and the refraction index dispersion. Such approach allows to study the properties of samples with strong IR absorption (i.e. aqueous systems) and non transparent mediums. For the other hand, the equipment, provided by Anton-Paar Co., makes it possible a simultaneous measurement of sound velocity and density.

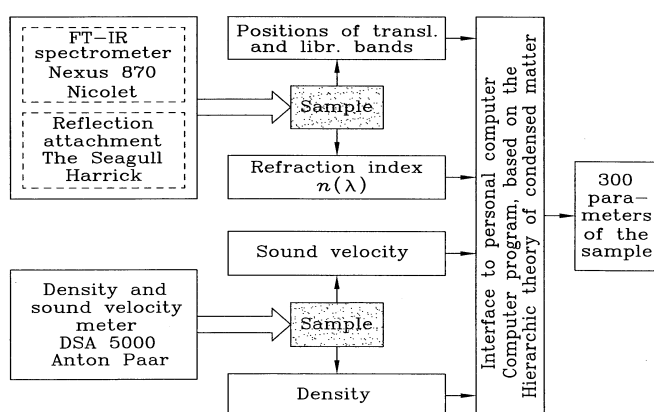

Table 2. One of the possible configuration of Comprehensive analyzer of Matter Properties (CAMP)

The unified system of modified FT-IR and/or Raman spectrometer, densitometer, sound velocimeter, refractometer, measuring the same sample at similar conditions is necessary to assembly. Simulation of corresponding parameters, using the interface of such system with personal computer will provide CAMP function.

The another configuration of CAMP may include the FT-Brillouin light scattering spectrometer, based on Fabry-Perrot interferometer. It makes possible simultaneous measurement of hypersound velocity (from the Doppler shift of side bands of Brillouin spectra) and positions of intermolecular bands [tr and lb] from the Stokes/antiStokes satellite components on the central peak of Brillouin spectra. This means combination of possibilities of Raman spectroscopy and sound velocimetry.

CAMP may allow monitoring of perturbation of very different physical properties of condensed matter under the influence of solute molecules in dilute solutions and external electromagnetic or acoustic fields.⁷

Comprehensive Analyzer of Matter Properties (CAMP) represents a basically new type of scientific equipment, allowing to get incomparable big amount of information concerning physics of liquids or solids. It can be very useful for investigation of dynamics and mesoscopic structure of pure matter as well as solid and liquid solutions, the colloid systems and host-guest systems.

The demo-version of CAMP-computer program is available and may be ordered from the author or directly downloaded from the front page of web site: www.karelia.ru/~alexk [see also 'Looking for partners']. This program demonstrates potential possibilities of new optoacoustic device on examples of water and ice.

2. Water as a Regulating Factor of Biopolymers Properties and Evolution

The dynamic model of proteins⁵ leads to the following classification of dynamics in the native globular proteins (see also <http://arXiv.org/abs/physics/0003093>).

1. *Small-scale (SS) dynamics*: low amplitude (less than 1 Å) thermal fluctuations of atoms, aminoacids residues, and displacements of alpha - helices and beta - structures within domains and subunits, at which the effective Stokes radius of domains does not change. This type of motion can differ in the content of A and B conformers, corresponding to closed and open to water interdomain and intersubunit cavities. The range of characteristic times at SS dynamics of the surface aminoacids residues is around ($10^{-10} - 10^{-12}$) sec., determined by activation energies of conformational transitions and microviscosity. It corresponds to calculated frequency of ($a \rightleftharpoons b$) transitions of primary translational [tr] effectons (Fig. 2.2). The SS internal vibrations of aminoacids in rigid core of domains may be very slow $\sim 10^4 \text{ s}^{-1}$;

2. *Large-scale (LS) dynamics* is subdivided into *LS-pulsation* and *LS-librations* (see Fig.2.1) in form of limited diffusion of domains and subunits of proteins:

a) *LS-pulsations* are represented by relative translational-rotational displacements of domains and subunits at distances about 3 Å or more. Thus, big cavities of proteins, fluctuate between states of less (A) and more (B) water-accessibility. The life-times of these states depending on protein structure and external conditions are in the range of (10^{-4} to 10^{-7}) s. The [A - B] pulsations are accompanied by reversible sorption-desorption of (20 - 50) water molecules from the protein's cavities;

b) *LS-librations* represent the relative rotational - translational motions of domains and subunits in composition of A and B conformers with correlation times $\tau_M \simeq (1 - 5) \cdot 10^{-8}$ s without [A - B] transitions.

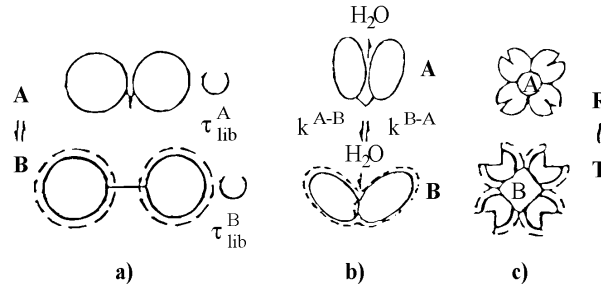

Figure 2.1 Examples of large-scale (LS) protein dynamics: $A \leftrightarrow B$ pulsations and librations with correlation times ($\tau_{\text{lib}}^B < \tau_{\text{lib}}^A$) (Kaivarainen, 1985, 1995): a) mobility of domains connected by flexible hinge or contact region, like in the light chains of immunoglobulins; b) mobility of domains that form the active sites of proteins, like in hexokinase, papain, pepsin, lysozyme etc. due to flexibility of contacts; c) mobility of subunits forming the oligomeric proteins like hemoglobin. Besides transitions of the active sites of each subunit, the ($A \leftrightarrow B$) pulsations with frequencies of ($10^4 - 10^6$) s^{-1} are pertinent to the common central cavity.

The librational mobility of domains and subunits is revealed by the fact that the experimental value of τ_M is less than the theoretical one (τ_M^t) calculated on the Stokes-Einstein formula:

$$\tau_M^t = (V/k) \eta/T \quad 2.1$$

This formula is based on the assumption that the whole protein can be approximated by a rigid sphere. It means, that the large-scale dynamics can be characterized by the "flexibility factor", in the absence of aggregation equal to ratio:

$$fl = (\tau_M/\tau_M^t) \leq 1 \quad 2.2$$

LS - librations of domains are accompanied by "flickering" of water cluster in the open cavity between domains or subunits. The process of water cluster "flickering", i.e. [disassembly \rightleftharpoons assembly] is close to the reversible first-order phase transition, when:

$$\Delta G_{H_2O} = \Delta H_{H_2O} - T\Delta S_{H_2O} \approx 0 \quad 2.3$$

Such type of transitions in water-macromolecular systems could be responsible for so called "enthalpy-entropy compensation effects".

2.1 Role of water in dynamics of proteins

The "flickering clusters" means excitation of [lb/tr] conversions between librational and translational primary water effectons, accompanied by [association/dissociation] of coherent water.

The water cluster (primary lb effecton) association and dissociation in protein cavities in terms of mesoscopic model represent the (ac) - convertons or (bc) - convertons. These excitations stimulate the LS- librations of domains in composition of B-conformer. The frequencies of (ac) and (bc) convertons, has the order of about $10^8 c^{-1}$, like the frequency of primary librational effectons excitation. This value coincides well with experimental characteristic times for protein domains librations Fig 2.2 b. The (ac) and (bc) convertons represent transitions between similar states of primary librational and translational effectons: [$a_{lb} \rightleftharpoons a_{tr}$] and [$b_{lb} \rightleftharpoons b_{tr}$] (see Introduction).

For the other hand, the Macroconvertons, representing simultaneous excitation of ($ac + bc$) convertons, are responsible for [$B \rightleftharpoons A$] large-scale pulsations of proteins. The frequency of macroconvertons excitation is about $5 \cdot 10^6 s^{-1}$ at physiological temperatures (Fig.2.2c).

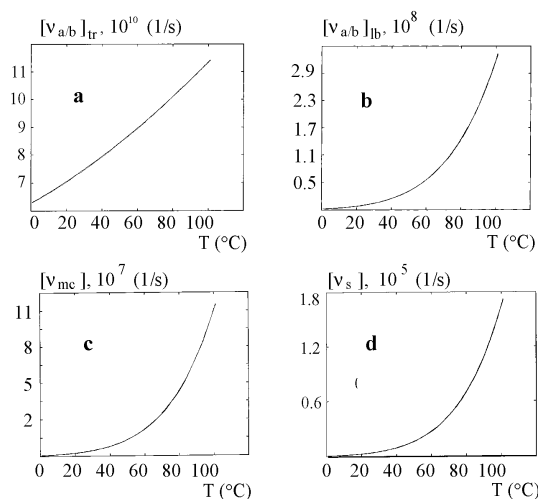

Figure 2.2. (a) - Frequency of primary $[tr]$ effectons excitations;
 (b) - Frequency of primary $[lb]$ effectons excitations;
 (c) - Frequency of $[lb/tr]$ Macroconvertons (flickering clusters) excitations;
 (d) - Frequency of Superdeformons excitations.

At the temperature interval $(0-100)^{\circ}C$ the frequencies of translational and librational macrodeformons (tr and lb) are in the interval of $(1.3-2.8) \cdot 10^9 s^{-1}$ and $(0.2-13) \cdot 10^6 s^{-1}$ correspondingly.

The calculated frequency of primary translational effectons $[a \leftrightarrow b]_{tr}$ excitations at $20^{\circ}C$ (Fig. 2.2 a) is $\nu \sim 7 \cdot 10^{10} (1/s)$. It corresponds to electromagnetic wave length in water $\lambda = (cn)/\nu \sim 6mm$ with refraction index ($n = 1.33$). For the other hand, there are a lot of evidence, that irradiation of very different biological systems with such coherent electromagnetic field exert great influences on their properties.

The frequency of Superdeformons excitation (Fig.2.2d) is much lower, than that of macroconvertons: $\nu_s \sim (10^4 - 10^5) s^{-1}$. Superdeformons are responsible for cavitational fluctuations in liquids and disassembly of protein filaments. The pulsation frequency of oligomeric proteins, like hemoglobin or disassembly (peptization) of actin and microtubules could be also related with such big fluctuations. The life-times of (A) and (B) conformer markedly exceeds the transition-time between them (10^{-9} to 10^{-11}) s.

The (A - B) pulsations of various cavities in allosteric proteins are correlated. The corresponding A and B conformers have different Stokes radii and effective volume. The geometrical deformation of the inter-subunits large central cavity of oligomeric proteins and the destabilization of the water cluster located in it, lead to relaxational change of (A - B) equilibrium constant, providing their cooperative properties.

At the temperature interval $(0-100 C^{\circ})$ the frequencies of translational and librational macrodeformons (tr and lb) are in the interval of $(1.3-2.8) \cdot 10^9 1/s$ and $(0.2-13) \cdot 10^6 s^{-1}$ correspondingly. It is obvious, that between the dynamics/function of proteins, membranes, etc. and dynamics of their aqueous environment the strong correlation exists.

2.2 The role of water in mechanism of protein-ligand specific complex formation and signal transmission between domains and subunits

According to our model of specific complexes formation the following order of events is assumed (Fig. 2.3):

1. Ligand (L) collides with the active site (AS), formed usually by two domains, in its open (b) state: the structure of water cluster in AS is being perturbed and water is forced out of AS cavity totally or partially;
2. Transition of AS from the open (b) to the closed (a) state occurs due to strong shift of $[a \leftrightarrow b]$ equilibrium to the left, i.e. to the AS domains large scale dynamics;
3. A process of dynamic adaptation of complex $[L+AS]$ begins, accompanied by the directed

ligand diffusion in AS cavity due to its domains small-scale dynamics and deformation of their tertiary structure;

4. If the protein is oligomeric with few AS, then the above events cause changes in the geometry of the central cavity between subunits in the open state leading to the destabilization of the large central water cluster and the shift of the $A \rightleftharpoons B$, corresponding to $R \rightleftharpoons T$ equilibrium of quaternary structure leftward. Water is partially forced out from central cavity.

Due to the feedback mechanism this shift can influence the $[a \leftrightarrow b]$ equilibrium of the remaining free AS and promotes its reaction with the next ligand. Every new ligand stimulates this process, promoting the positive cooperativity. The negative cooperativity also could be resulted from the interaction between central cavity and active sites;

5. The terminal [*protein – ligand*] complex is formed as a consequence of the relaxation process, representing deformation of domains and subunits tertiary structure. This stage could be much slower than the initial ones [1-3]. As a result of it, the stability of the complex grows up.

Dissociation of specific complex is a set of reverse processes to that described above which starts from the $[a^* \rightarrow b]$ fluctuation of the AS cavity.

In multidomain proteins like antibodies, which consist of 12 domains, and in oligomeric proteins, the cooperative properties of H_2O clusters in the cavities can determine the mechanism of signal transmission from AS to the remote effector regions and allosteric protein properties.

The stability of a librational water effecton as coherent cluster strongly depends on its sizes and geometry. This means that very small deformations of protein cavity, which violate the [cavity-cluster] complementary condition, induce a cooperative shift of $[A \leftrightarrow B]$ equilibrium leftward. The clusterphilic interaction, introduced earlier^{5,6} turns to hydrophobic one due to $[lb/tr]$ conversion.

This process can be developed step by step. For example, the reorientation of variable domains, which form the antibodies active site (AS) after reaction with the antigen determinant or hapten deforms the next cavity between pairs of variable and constant domains forming F_{ab} subunits (Fig.2.3). The leftward shift of $[A \leftrightarrow B]$ equilibrium of this cavity, in turn, changes the geometry of the big central cavity between F_{ab} and F_c subunits, perturbing the structure of the latter. Therefore, the signal transmission from the AS to the effector sites of F_c subunits occurs due to the balance shift between clusterphilic and hydrophobic interactions. This signal may be responsible for complement- binding sites activation and triggering the receptors function on the lymphocyte membranes.

The leftward shift of $[A \leftrightarrow B]$ equilibrium in a number of cavities in the elongated multidomain proteins can lead to the significant decrease of their linear size and dehydration. The mechanism of muscular contraction is probably based on such phenomena and clusterphilic interactions. The clusterphilic interactions means that interaction of the open protein cavity with water cluster is energetically more preferable, than with the same number of molecules after cluster disassembly.⁶

For such a nonlinear system the energy is necessary for reorientation of the first couple of domains only. The process then goes on spontaneously with decreasing the averaged protein chemical potential. The chemical potential of the A- conformer is usually lower than that of B- conformer ($\bar{G}_A < \bar{G}_B$) and the relaxation of protein is accompanied by the leftward $A \leftrightarrow B$ equilibrium shift of cavities, accompanied by decreasing of the averaged protein dimensions.

The shift of $[A - B]$ equilibrium of central cavity of oligomeric proteins determines their cooperative properties during consecutive ligand binding in the active sites. Signal transmission from the active sites to the remote regions of macromolecules is also dependent of $[A - B]$ equilibrium(Fig. 2.3).

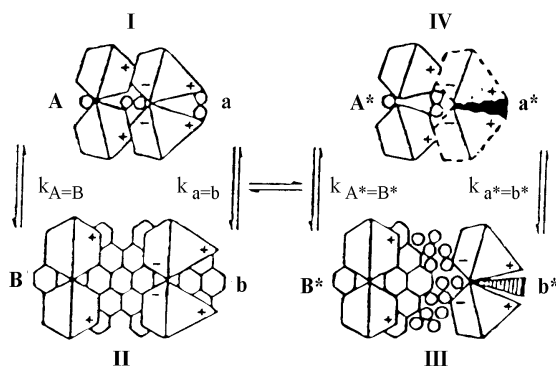

Figure 2.3. The schematic picture of the protein association (Fab subunits of antibody with a ligand), which is accompanied by destabilization of water clusters in cavities, according to dynamic model (Kaivarainen, 1985). The dotted line denotes the perturbation of the tertiary structure of the domains forming the active site. Antibodies of IgG type contain usually two such Fab subunit and one Fc subunit, conjugated with 2Fab by flexible hinge, forming the general Y-like structure.

The evolution of the ideas of the protein-ligand complex formation proceeded in the following sequence:

1. "Key-lock" or the rigid conformity between the geometry of an active site and that of a ligand (Fisher, 1894);
2. "Hand-glove" or the so-called principle of induced conformity (Koshland, 1962);
3. At the current stage of complex-formation process understanding, the crucial role of protein dynamics gets clearer. Our model allows us to put forward the "Principle of Stabilized Conformity (PSC)" instead that of "induced conformity" in protein-ligand specific reaction (Kaivarainen, 1985).

Principle of Stabilized Conformity (PSC) means that the geometry of the active site (AS), optimal from energetic and stereochemical conditions, is already existing *before* reaction with ligand. The optimal geometry of AS is to be the only one selected among the number of others and stabilized by ligand, but not induced "de nova".

2.3 The role of water in spatial parameters of proteins

The number of water molecules within the primary librational effectons of water, which could be approximated by a cube, decreases from 280 at (0°C) to 3 at (100 °C) (Fig. 2.4). It should be noted that at physiological temperatures (35-40 C) such quasiparticles contain nearly 40 water molecules. This number is close to that of water molecules that can be placed in the open interdomain protein cavities judging from X-ray data⁵. Structural domains are space-separated units with a mass of (1-2)·10⁻³ D. Protein subunits, as a rule consist of two or more domains.

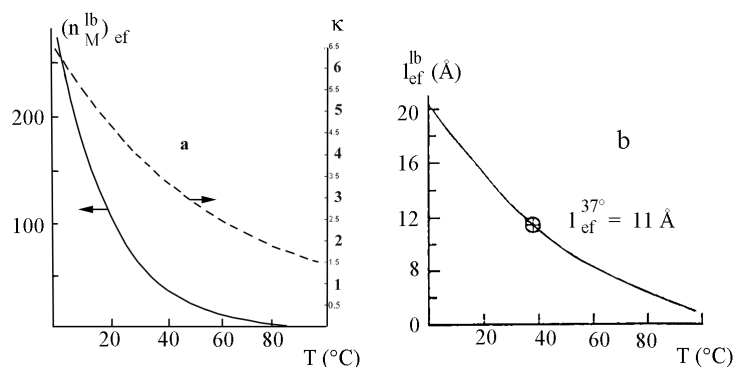

Figure 2.4. (a) : The temperature dependencies of the number of H_2O molecules in the volume of primary librational effecton $(n_M^{lb})_{ef}$, left axis) and the number of H_2O per length of this effecton edge (κ , right axis); (b): the temperature dependence of the water primary librational

effecton (approximated by cube) edge length [$l_{ef}^{lib} = \kappa(V_0/N_0)^{1/3}$].

The number of H_2O molecules within the *primary librational effectons* of water, which could be approximated by a cube, decreases from $n_M = 280$ at 0^0 to $n_M \simeq 3$ at 100^0 (Fig. 3a). It should be noted that at physiological temperatures ($35 - 40^0$) such quasiparticles contain nearly 40 water molecules. Similar by order dimensions of heavy water clusters (about 10 Å) with saturated hydrogen bonds were revealed using inelastic neutron scattering method by Texeira et al., in 1987.

The dimensions of water clusters are close to dimensions of the open interdomain protein cavities judging from X-ray data (Kaivarainen, 1985). The flickering of these clusters, i.e. their [disassembly \rightleftharpoons assembly] due to [lb\tr] conversions in accordance to our model is directly related to the large-scale dynamics of proteins, presented on Fig. 2.1).

It is important finding that the linear dimensions of the interdomain water clusters (about 11 Å) in 'open' states of protein cavities at physiological temperature, calculated using our software, are close to common ones for protein domains. Such spatial correlation indicate that the properties of water exerted a strong influence on the biological evolution of macromolecules, namely, their dimensions and allosteric properties due to cooperativity of intersubunit water clusters.

The correlation between dimensions of microtubules (about 10 microns) and wave-length of standing librational IR photons, composing primary electromagnetic deformons in water, points that not only spatial characteristics of biopolymers, but also the cell's dimensions are determined by water properties [1, 2]. Consequently, the calculations, based on our hierarchic theory, give a strong evidence, that water was one of the most important factors in evolution of biopolymers and cells.

The new mechanism of ATP hydrolysis energy utilization in muscle contraction and role of water in cancer also is presented in full paper <http://arXiv.org/abs/physics/0003093>.

3. Multi-Fractional Model of Interfacial Water Structure. Its Contribution to Morphogenetic Field

Our model of multi-fractional water structure, formed on solid-liquid interface, is based on Hierarchic theory of condensed matter.^{3,6} Classification and description of FOUR interfacial water fractions, in accordance to our Multi-fractional model of interfacial (solid-liquid) water structure:

1. *The first fraction is Primary hydration Shell (PS)* with maximum energy of interaction with surface. The structure and dynamics of this 1st fraction can differ strongly from those of bulk water. Its thickness: corresponds to 1-3 solvent molecule. In accordance to generally accepted and experimentally proved models of hydration of macromolecules and colloid particles, we assume that PS of strongly bound water molecules, serves like intermediate shell, neutralizing the specific chemical properties of surface (charged, polar, nonpolar, etc.). Such strongly bound water can remain partially untouched even after strong dehydration of samples in vacuum. This 1st fraction of interfacial water serves like a matrix for second fraction - vicinal water shell formation. The properties of vicinal water are independent on specific chemical structure of the surface - from quartz plates, mineral grains and membranes to large macromolecules (Clegg and Drost-Hansen, 1991). This can be a result of "buffering" effect of primary hydration shell;⁸

2. *The second fraction - vicinal water (VW)* is formed by primary librational [lb] effectons - coherent molecular clusters with properties of mesoscopic Bose-condensate (mBC) with saturated hydrogen bonds and less density than the average one of bulk water. It is a result of [lb] effecton adsorption from the bulk volume on the primary hydration shell (PS). Vicinal water (VW) can be formed in the volume of pores, near the curved and plate interfaces as a result of interaction with strongly surface-bound water of PS.

The decreasing of most probable [lb] thermal momentums of water molecules, especially in direction, normal to the surface of macromolecule or colloid particle as a consequence of

interaction with primary shell (PS), should lead to increasing of corresponding edge's length of primary [lb] effectons, forming VW, as compared to the bulk water effectons. This selected immobilization of water molecules change the cube-like shape of effectons of the bulk water to shape of elongated parallelepiped for the effectons of VW. It is a result of increasing of corresponding wave B length of water molecules as a ratio of Plank constant to their most probable momentum.

The increasing of life-time of these enlarged primary [lb] effectons in the (a) state - means the increasing of their stability and concentration in the volume of VW.

As far we assume, that VW is a result of adsorption of primary librational effectons on primary hydration shell and their elongation in direction, normal to surface, we can make some predictions: a) The thickness of VW can be about 30-75 Å, depending on properties of surface (geometry, polarity), temperature, pressure and presence the perturbing solvent structure agents (the linear dimension of primary librational effecton of bulk water at 25⁰C is only about 15 Å); b) The elongation of primary [lb] effectons in direction, normal to the surface, should be resulted in increasing the intensity of librational IR photons superradiation in the same direction;⁶ c) The vicinal water (VW) of second interfacial fraction should differ by number of physical parameters from the bulk water.

For example, VW should have: lower density; bigger heat capacity; bigger sound velocity; bigger viscosity; smaller dielectric relaxation frequency, etc. The lower mobility of water molecules of vicinal water is confirmed directly by almost 10 times difference of dielectric relaxation frequency (2·10⁹ Hz) as respect to bulk one (19·10⁹ Hz).⁸ The increasing of temperature should lead to decreasing the vicinal librational effectons dimensions and thickness of VW shell;

3. *The third fraction of interfacial water*: surface-stimulated Bose-condensate (SS-BC) is represented by 3D network of primary [lb] effectons (mBC) with a thickness of (50-300 Å), stabilized by Josephson contacts. It is a next hierarchical level of interfacial water self-organization, using the second vicinal fraction (VW) as a matrix of nucleation centers for SS-BS. The time of gradual formation of this 3D net of linked to each other coherent clusters (strings of polyeffectons), can be much longer than that of VW and more sensitive to temperature and mechanical perturbations. The second and third fractions of interfacial water can play an important role in biological cells activity regulation;

4. The biggest and most fragile *forth fraction* of interfacial water is a result of slow orchestration of bulk primary effectons in the volume of primary (electromagnetic) [lb] deformons. The primary deformons appears as a result of superposition of three standing IR librational photons, normal to each other. Corresponding IR photons are radiated by the enlarged primary [lb] effectons of vicinal water and those of SS-BC. The linear dimension of librational IR deformons is about half of librational IR photons wave length, i.e. 5 microns.

This "electromagnetically orchestrated water (EM-OW)" fraction easily can be destroyed not only by temperature increasing, ultrasound and Browning movement, but even by mechanical shaking. The time of spontaneous reassemble of this fraction after destruction has an order of hours and is dependent strongly on temperature, viscosity and dimensions of colloid particles.

3.1 Possible role of interfacial water near cell's microfilaments in morphogenetic field formation

In biosystems, like living cells, the IR radiation of second (VW) and third (SS-BC) fractions of interfacial water, orchestrated in the internal core of microtubules (MT) and around MTs and actin filaments, may contribute to "morphogenetic field", revealed by A. Gurwicz in form of EM field. Later it was confirmed in different laboratories, that EM radiation is accompanied the cells division and differentiation. The directed IR *superradiation* of interfacial water in cytoplasm should be dependent on orientation of microtubules and actin filaments. The known non-linear optical effect - "superradiation"⁹ is a part of our Hierarchic theory of matter.^{3,5} It is a consequence of water coherent clusters - mesoscopic Bose condensate (mBC) ability to quantum beats between their optic and acoustic modes. Superradiation should be maximum from the ends

of microtubules, in accordance with theory of this effect. Superposition of corresponding coherent IR photons can be responsible for formation of primary deformons, stimulating cavitational fluctuations in certain volumes of cytoplasmic water and reversible disassembly of MTs and actin filaments.

In accordance to our Hierarchic model of consciousness, described in next section, the intensity of IR coherent photons superradiation is maximum from the ends of microtubules (MTs). Their superposition leads to formation of hologram like system of primary deformons, responsible for distant cell-cell interaction and regulation of their cytoplasmic dynamics. The structure of microtubules is presented on Fig. 3.1.

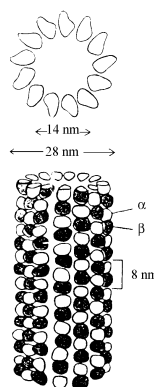

Figure 3.1. Construction of microtubule from α and β tubulins, globular proteins with molecular mass 55 kD, existing in form of dimers ($\alpha\beta$).

Each $\alpha\beta$ dimer is a dipole with negative charges, shifted towards α subunit. Consequently, microtubules, as an oriented elongated structure of dipoles system, have the piezoelectric properties (Athestaedt, 1974).

Hollow core of MT is has a diameter of 140 Å. All the internal water of MT may represent the 1st, 2nd and 3d fractions of interfacial water, described above. The spatial orientation of two bundles of MTs, containing about $2 \cdot 25 = 50$ MTs is determined by orientation of two centrioles, forming as a rule the right angle (Fig 4.1). Consequently, the directions of penetration of IR librational photons, superradiated from the ends of MTs, usually fixed on cell's membrane, also have the almost right angle relative orientation. Interception of these coherent IR photons with those, superradiated by other cells leads to formation of 3D standing waves, i.e. IR primary [lb] deformons with linear dimension of 5 microns ($1/2$ [lb] photon wave-length).

Distribution of density of inorganic ions, especially bivalent like Ca^{2+} , and probability of their fluctuations, affecting the water activity, should be regulated by anisotropy of the electric field tension in the volume of 3D electromagnetic standing waves. We suppose, that the corresponding spatial distribution of water activity ($a_{\text{H}_2\text{O}}$) plays the important modulation role in proteins dynamics/function and dynamic equilibrium of [assembly \rightleftharpoons disassembly] of microtubules and actin filaments, responsible for cell's shape.

The process of cavitational fluctuations 'collapsing' with frequency of superdeformons excitation ($\sim 10^4$ Hz) is accompanied by high-frequency (UV and visible) "biophotons" radiation due to recombination of dissociated to hydroxyl and proton water molecules. These biophotons may be responsible for short range morphogenetic field in contrast to coherent IR photons, standing for long-range morphogenetic field.

This could be one of the possible mechanism of morphogenetic field action. The another component of morphogenetic field may be related with superposition of virtual replicas (VR) of DNA, microtubules, actin filaments, responsible for cells 3D structure. The notion of VR leads from our Unified model of Bivacuum and wave - corpuscle duality, as base for quantum entanglement, discussed in section 5 of this paper.

3.2 Infrared Laser and Ultrasound Radiation Based Cancer Cells

Selective Desintegrator

The idea of selective cancer cells desintegrator is based on *biophysical* mechanism of cancer emergence (Kaivarainen, 1995; 2000). The absence of contact inhibition in the case of cancer cells population growth may be a result of insufficient decreasing of water activity between cells, because of specific [*cell – cell*] contacts destruction. The shape of normal cells under control of cell's filaments is a specific one, providing good dense contacts between cells with limited amount of water in the inter cell space, in contrast to contacts of transformed cells.

The primary reason of these contacts deterioration can be a shift of dynamic equilibrium: [assembly - disassembly] of microtubules (MT) and actin filaments to the right due to mistakes in biosynthesis of their subunits. The partial disassembly of cytoskeleton's actin filaments and microtubules may also be a result of some genetically controlled mistakes in biosynthesis of membrane channels (ionic pumps), leading to increasing of concentration of $[Ca^{2+}]$ ions in cytoplasm (Kaivarainen, 1995). Decreasing of concentration of any other types of ions: Na^+ ; K^+ ; H^+ ; Mg^{2+} in cytoplasm, as the result of corresponding ionic pumps destruction, also may lead to disassembly of filaments.

The amount of water, involved in hydration shells of the actin and tubulin subunits increases after their dissociation, and the water activity in cytoplasm decreases, correspondingly. As a consequence of concomitant osmotic water 'pumping' into cells, they tend to swell and acquire a nonspecific ball-like shape. Finally, the number and density of direct contacts between the membranes of transformed cells decreases and the mechanism of contact inhibition of cells division become destroyed. Normally, the certain decline of the water activity between cells could be a triggering signal for inhibition of cell division (proliferation).

Our *biophysical* model of cancer emergency is in accordance with available experimental data.

One of possible approach to problem of tumor inhibition and organism healing, based on our model, is related to the decreasing of intra-cell water activity by means of chemical and physical factors for restoration the contact inhibition.

Another approach to cancer healing, based on mechanism described above, is the IR laser treatment of transformed cells with IR photons frequencies (about $3 \cdot 10^{13} \text{ s}^{-1}$), stimulating excitation of cavitation fluctuations in water (emergency and collapsing of microbubbles), inducing a collective disassembly of microtubules (MTs), actin filaments and *gel* → *sol* transition. The corresponding centriols destruction will prevent cells division and should give a good therapeutic effect. The IR Laser based selective cancer cells eliminator, proposed here, can be combined with ultrasound (US) treatment of tissues and blood. Such US treatment with frequency of about 40 kHz in accordance to our Hierarchic theory of water should make cancer cells more sensitive to IR laser beam action and increases the probability of cavitation fluctuations in water.

The method of cancer cells elimination, proposed here, is based on assumption that stability of MTs in transformed cells is weaker than that of normal cells. This difference should provide the selective of action of the ultrasound and laser beam on the cancer and normal cells, remaining the normal cells undamaged.

Hierarchic theory of condensed matter (see section 1), verified by computer simulations on examples of water and ice, predicts the frequency in radio frequency range of about 10^7 Hz , modulating the above mentioned carrying frequency of IR radiation. Such EM modulation, like the combination with ultrasound treatment, should increase the yield of cancer cells destruction effect in blood and tissues of patients.

4. Hierarchic Model of Consciousness:

From Molecular Bose Condensation to Synaptic Reorganization

Our Hierarchic Model of Consciousness (HMC)^{10,11} is based on Hierarchic Theory of Matter, developed by the author.^{3,5}

The idea of Karl Pribram of his book: 'Languages of the Brain' (1977) of holographic principles of memory and braining is very popular in quantum models of consciousness. Our model also supports this general idea and try to transform it in concrete shape. The code way of keeping information in the form of the effectons and deformons as 3D standing waves (de Broglie waves, electromagnetic, acoustic and vibro-gravitational), generated by microtubules, containing water in state of mesoscopic Bose condensation (mBC) - looks very effective and may be used in quantum computer technology¹⁰.

Hameroff and Penrose^{12,13} proposed the "orchestrated objective reduction (Orch OR)" model of quantum computation in microtubules (MT) of brain. They suppose, that quantum nonlocal interaction between huge number of MT may provide coherency of their thermal dynamics. Based on principle of uncertainty in coherent form it was calculated, that if the difference in volume of alternative states of very big number (10^9) of dynamically coherent tubulin dimers ($\alpha\beta$) is about 10% during 0.5 s (arbitrary assumption), the quantum gravity induced self-collapse to one quantum state may occur.

The idea of Penrose and Hameroff about quantum gravity induced self-collapse of MT system is compatible with our model, if we assume, that collapse is resulted from change of mass of fraction of mBC of water molecules in hollow core of microtubules, triggered by membranes depolarization. The mBC_{H_2O} of water and mBC_{MT} of microtubules may form the unified [water - protein] coherent quantum domains with dimensions of few nanometers, which may be regulated by ($\alpha\beta$) dimers conformation and dynamics.

4.1 Properties of Actin Filaments, Microtubules and Internal Water

The actin filaments are composed from two chains of G-actin, forming double helix with diameter of 40 Å. The actin filaments are the polar structure with different properties of two ends. Disassembly of actin and (*gel* → *sol*) transition is dependent strongly on water activity and energy of thermal fluctuation. Polymerization of actin do not needs energy. Simple increasing of salt concentration (decreasing of water activity), approximately till to physiological one - induce polymerization and strong increasing of viscosity in cytoplasm.

Microtubules sometimes can be as long as axons of nerve cells, i.e. tenth of centimeters long. Microtubules (MT) in axons are usually parallel and are arranged in bundles. Microtubules associated proteins (MAP) form a "bridges", linking MT and are responsible for their interaction and cooperative system formation. Brain contains a big amount of microtubules. *Their most probable length is about 10^5 Å.*

Strong interrelation must exist between properties of internal water in MT and structure and dynamics of their walls, depending on [$\alpha - \beta$] tubulins interaction. The biggest cavitation fluctuations of internal water - (superdeformons) in the volume of 3D standing IR photons can induce total cooperative disassembly of MT, leading to [*gel* → *sol*] transition in cytoplasm. Superdeformons excitation in MT internal water could be an explanation of experimentally revealed dynamic instability (catastrophes).

The equilibrium of "closed" (A) and "open" (B) states of nonpolar cavities between α and β tubulins in ($\alpha\beta$) dimers can be shifted to the (B) one, under the change of external electric field in a course of membrane depolarization. It can be a consequence of piezoelectric properties of MTs and will stimulate the formation of coherent water clusters in the open nonpolar cavities of ($\alpha\beta$) dimers. The open cavities can serve as a centers of molecular Bose condensation (mBC) in form of coherent water cluster.

The relative orientation of MT in different cells, optimal for maximum [MT-MT] resonance interaction by means of coherent IR photons, could be achieved due to twisting of centrioles, changing spatial orientation of MT.

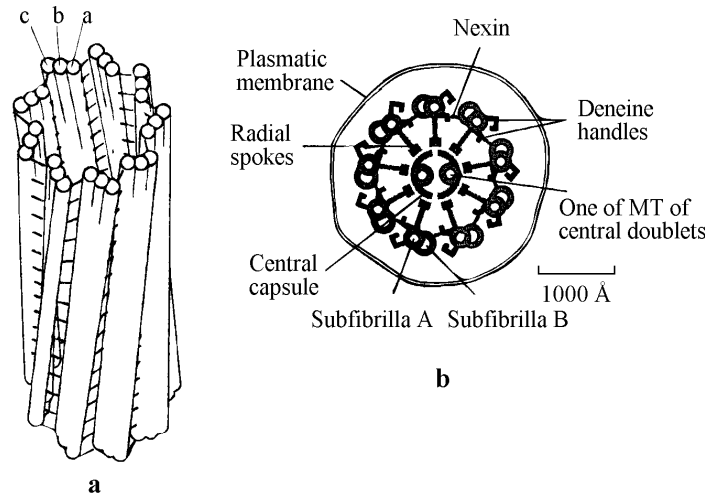

Figure. 4.1. (a) : The scheme of centriole construction from nine triplets of microtubules. The length and diameter of cylinder are 3000 Å and 1000 Å, correspondingly. Each of triplets contain one complete microtubule (MT) and two noncomplete MT; (b): the scheme of cross-section of cilia with number of MT doublets and MT-associated proteins (MAP): $[2 \cdot 9 + 2] = 20$. One of MT of periphery doublets is complete and another is noncomplete (subfibrilles A and B).

Results of our computer simulations for pure *bulk* water shows, that the distance between centers of primary [lb] effectons, approximated by cube exceed their linear dimension to about 3.5 times (Fig 4.2b). For our case of interfacial water in MTs, when the librational effecton's edge can be about 23 Å at physiological temperature, it means that the average distance between the effectons centers is about: $d = l_{ef}^{lb} \cdot 3.5 = 23 \cdot 3.5 \sim 80 \text{Å}$. This corresponds well to equidistant (80 Å) spacing between clefts of ($\alpha\beta$) dimers in the internal core of MT. Such a regular spatial distribution of the internal flickering water clusters in MT is an important factor for realization of the [optoacoustic - conformational] signal propagation along the MT, accompanied by correlated radiation/absorption of librational ($\sim 700 \text{cm}^{-1}$) IR photons and alternating closing *and* opening clefts between α and β tubulins (see Fig. 4.3).

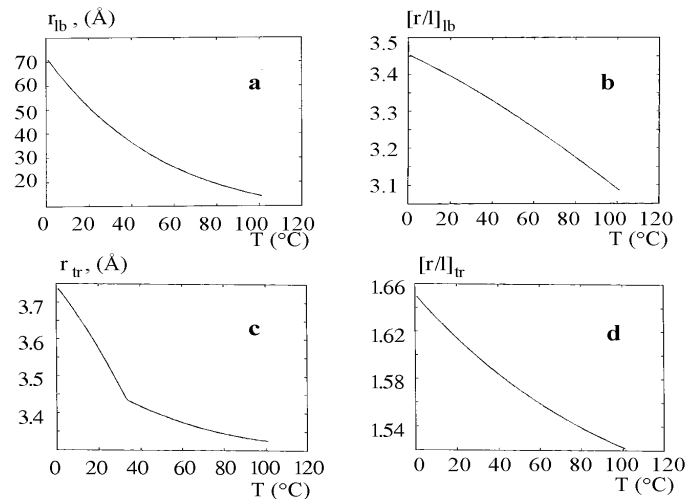

Figure. 4.2. Theoretical temperature dependencies of: (a) - the space between centers of primary [lb] effectons; (b) - the ratio of space between primary [lb] effectons to their length; (c) - the space between centers of primary [tr] effectons; (d) - the ratio of space between primary [tr] effectons to their length.

At the "rest" state the resulting concentration of internal anions of neurons is bigger than that of external ones, providing the difference of potentials equal to 50-100 mV. As far the thickness

of membrane is only about 50\AA , it means that the gradient of electric tension is about: 100.000 V/cm i.e. it is extremely high. It is changing strongly in the process of reversible depolarization of membranes.

The [gel-sol] transition, induced by cavitational fluctuations of water in cytoplasm (superdeformons) and MTs disassembly, can be accompanied by coherent "biophotons" emission/absorption in the ultraviolet (UV) and visible range. Such radiation is possible due to water molecules [dissociation \rightleftharpoons recombination] in a course of cavitational fluctuations. These high-frequency coherent photons exchange, like the IR photons and nerve impulses may be responsible for synchronized firing of distant neuron ensembles in head brain.¹⁴ The firing is a complex nonlinear process. Its characteristic time of about 1/50 of second (20ms) is much longer than pure quantum phenomena in MTs.

One of the important consequence of our HMC is that interactions of distant neurons in head brain can be realized not only by means of nerve impulse propagation via axons. Simultaneous neurons excitation may be accompanied also by resonant photon exchange between MT of the 'tuned' distant neurons.

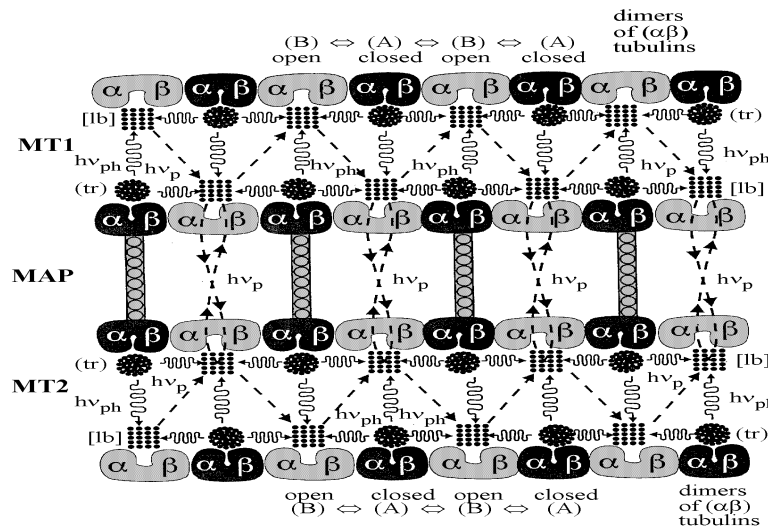

Figure .4.3 The schematic presentation of the local, acousto-conformational and distant - electromagnetic interactions between microtubules (MT1 and MT2), connected by MAP.

MAP– microtubules associated proteins stabilize the overall structure of MTs. They prevent the disassembly of MTs in bundles of axons and *cilia* in a course of their coherent bending. In neuron's body the concentration of MAP and their role in stabilization of MTs is much lower than in cilia. The local acousto-conformational signals between MT are realized via MTs - associated proteins (MAP), induced by transitions of the cleft, formed by α and β tubulins, between closed (A) and open (B) states. The orchestrated dynamics of individual MT as quantum conductor is a result of phonons ($h\nu_{ph}$) exchange between ($\alpha\beta$) clefts due to [lb/tr] conversions, corresponding to water clusters, "flickering", in-phase to [$B \rightleftharpoons A$] pulsations of clefts. The distant interactions between different MT are the consequence of IR photons and coherent vibro - gravitational waves exchange. The corresponding two types of waves are excited as a result of orchestrated ($a \rightleftharpoons b$) transitions of water primary librational effectons, localized in the open B- states of ($\alpha\beta$) clefts. Coherent disassembly or bending of MTs could be responsible for [volume/shape] pulsation of the nerve cells body or cilia bending. The former process is accompanied by redistribution of synaptic contacts on the surface of cells.

4.2 Stages of Hierarchic Model of Consciousness

In accordance with our HMC, the sequence of following interrelated stages is necessary for elementary act of perception and memory (see Fig.2), resulted from simultaneous excitation and depolarization of big enough number of neurons, forming cooperative ensemble:

1. The change of the electric component of neuron's body internal electromagnetic field as a

result of cells depolarization; 2. Opening the potential - dependent Ca^{2+} channels and increasing the concentration of these ions in cytoplasm. Activation of Ca^{2+} - dependent protein gelsolin, which stimulate fast disassembly of actin filaments; 3. Shift of $A \rightleftharpoons B$ equilibrium between the closed (A) and open to water (B) states of cleft, formed by α and β tubulins in tubulin pairs of microtubules (MT) to the right as a consequence of piezoelectric effect, induced by depolarization of membrane of nerve cell; 4. Increasing the life-time and dimensions of coherent "flickering" water clusters in MT, representing the 3D superposition of de Broglie standing waves of H_2O molecules in hollow core of MT. It is a result of the water molecules immobilization in the 'open' nonpolar clefts of $(\alpha\beta)$ dimers of MT; 5. Increasing the superradiance of coherent IR photons induced by synchronization of quantum transitions of the *effectons* between *acoustic* and *optic* like states. Corresponding increasing of probability of superdeformons (cavitational fluctuations) excitation in water of cytoplasm; 6. The *disassembly of actin filaments system to huge number of subunits, [gel \rightarrow sol] transition and increasing of water fraction in hydration shell of proteins in cytoplasm*. This transition is a result of cavitational fluctuations and destabilization of actin filaments by Ca^{2+} . Corresponding decreasing the water activity in cytoplasm - increases strongly the passive osmotic diffusion of water from the external volume to the cell; 7. As a consequence of previous stage, a jump-way increasing of the nerve cell body volume (pulsation), accompanied by disrupting the (+) ends of MTs with cytoplasmic membranes occur. This stage makes it possible for MTs to change their orientation inside neuron's body; 8. Spatial "tuning" - collective reorientation of MTs of simultaneously excited neurons to geometry, corresponding to minimum potential energy of distant (but not nonlocal) electromagnetic and vibro-gravitational interaction between MTs and centrioles twisting; 9. Decreasing the concentration of Ca^{2+} to the critical one, when disassembly of actin filaments is stopped and $[\text{gel} \rightleftharpoons \text{sol}]$ equilibrium shifts to the left again, stabilizing the new MTs system spatial configuration and corresponding nerve cell body volume and geometry. This new geometry of nerve cells after fixation of (+) ends of MTs back to plasmatic membrane - determine the new distribution of ionic channels activity and reorganization of synaptic contacts in all excited ensemble of neurons after relaxation, i.e. *short-term and long-term memory*.

This cyclic consequence (hierarchy) of quantum mechanical, physicochemical and classical nonlinear events can be considered as elementary acts of memorizing and consciousness. The total period of listed above stages can be as long as 500 ms, i.e. half of second.

The resonance wave number of excitation of superdeformons, leading from our model, is equal to 1200 ($1/\text{cm}$). The experiments of Albrecht-Buehler^{15,16} revealed that just around this frequency the response of surface extensions of 3T3 cells to weak IR irradiation is maximum. Our model predicts that IR irradiation of microtubules system *in vitro* with this frequency will dramatically increase the probability of microtubules catastrophes. It's one of the way to verify our model experimentally.

Except superradiance, two other known cooperative optic effects could be involved in supercatastrophe realization: *self-induced bistability and pike regime* of IR photons radiation. Self-induced bistability is light-induced phase transition. It could be related to nonlinear shift of $[a \rightleftharpoons b]$ equilibrium of primary librational water effectons in MT to the right, as a result of saturation of IR (lb)-photons absorption. As far the molecular polarizability and dipole moments in (a) and (b) states of the primary effectons - differs, such shifts of $[a \rightleftharpoons b]$ equilibrium should be accompanied by periodic jumps of dielectric permeability and stability of coherent water clusters. These shifts may be responsible for the pike regime of librational IR photons absorption and radiation. *As far the stability of b-states of lb effectons is less than that of a-states, the characteristic frequency of pike regime can be correlated with frequency of MTs - supercatastrophe activation.*

The Brownian effects, which influence reorientation of MTs system and probability of cavitational fluctuations, stimulating $[\text{gel} - \text{sol}]$ transition in elementary act of consciousness - represent in our model the *non-computational element of consciousness*. Other models relate this element to wave function collapsing.

4.3 The entropy-driven information processing

It leads from our HMC that changes of system of electromagnetic, acoustic and vibro-gravitational 3D standing waves in the ensemble of nerve cells, produced by the internal water of MTs in a process of braining - may change the properties of this water in a course of MT system reorientation and 'tuning'.

This process induces redistribution of probabilities of different water excitations in huge number of microtubules. It means corresponding change of informational entropy $\langle I \rangle$:^{10,11}

$$\langle I \rangle = \sum_i P_i \lg(1/P_i) = - \sum_i P_i \lg(P_i) \quad 4.1$$

where: P_i is a probability of the (i) state with energy (E_i), defined as:

$$P_i = \frac{\exp(-\frac{E_i}{kT})}{\sum_i \exp(-\frac{E_i}{kT})} \quad 4.2$$

For total system the relation between entropy (S) and information (I) is:

$$S(e.u.) = k \cdot \ln W = (k \cdot \ln 2)I = 2.3 \cdot 10^{-24} I (bit) \quad 4.3$$

where statistical weight of macro system is:

$$W = \frac{N!}{N_1! N_2! \dots N_q!} \quad 4.4$$

the total number of internal water molecules in macrosystem of interacting MT is:

$$N = N_1 + N_2 + \dots + N_q;$$

[q] is number of non degenerated states of 24 quasiparticles of the internal water in MTs.

The *reduced information* of condensed matter (Kaivarainen, 2000d) to the number of molecules (n_i) in each kind of excitations:

$$n_i = v_i/v_{H_2O} = (1/n_i)/(V_0/N_0) \quad 4.4a$$

- gives characteristic not only of quantity (I) but also about the quality of the information (**Iq**) for each collective excitation and their sum:

$$\langle \mathbf{Iq} \rangle = -[N_0/V_0] \cdot \sum_i P_i \lg_2(P_i)/n_i \quad 4.5$$

where N_0 and V_0 are the Avogadro number and molar volume; n_i is a concentration of excitation of (i)-type.

The distant energy exchange between MT, accompanied by the change of P_i for different excitations can be considered as an informational exchange between nerve cells. It is related to change of fractions of water excitations in system of interacting MTs.

4.4 Audio/Video Signals Skin Transmitter, Based on HMC

We propose the idea of new device, where the laser beam with energy of cavitation fluctuations activation, corresponding to wave number 1200 (1/cm), and ultraweak intensity will be modulated by acoustic and/or video signals. The modulated output optic signals will be transmitted from laser to the nerve nodes of skin, using wave-guides. It is supposed that the nerve impulses, stimulated by modulated laser beam, can propagate via complex axon-synapse system to brain centers, responsible for perception and processing of audio and video information. The long-term memorizing process also can be stimulated effectively by Skin Transmitter, as far it should increase the number of reorganized synaptic contacts.

The direct and feedback reaction between brain centers, responsible for audio and video

information processing and certain nerve nodes on skin, like acupuncture points, is predictable.

There are another resonant EM frequencies also, different from cavitational ones, for example the macroconvertions frequency, enable to stimulate big fluctuations of water in MTs and their disassembly. Verification of these important consequences of our model and elaboration of Audio/Video Signals Skin - Transmitter is the intriguing task of future. The practical realization of Audio/Video Signals Skin Transmitter will be a good additional evidence in proof of HMC and useful for lot of people with corresponding diseases.

The full paper on this subject is on-line <http://arXiv.org/abs/physics/0003045>).

The selective *cancer cells degenerator*, based on different probability of water cavitational fluctuation stimulation in cytoplasm of normal and cancer cells, has been also proposed (see section 3.2).

5. Unified Model of Bivacuum, Duality of Matter and Fields, as a Background of Psi-phenomena

The coherent physical theory of psi-phenomena is absent yet due to its high complexity and multilateral character. It is clear also, that such *Quantum-Psi* theory should be based on new physical paradigm, including unification of electromagnetism and gravitation.

The original mechanism of *Bivacuum* mediated Mind-Matter and Mind-Mind interaction, proposed, is based on the following stages of our long term efforts (see http://arXiv.org/find/physics/1/au:+Kaivarainen_A/0/1/0/all/0/1), including:

- Unified model of Bivacuum, [Corpuscle (C) \rightleftharpoons Wave (W)] duality of particles, Electromagnetism, Gravitation & Time. The Superfluous Energy of Asymmetric Bivacuum (<http://arXiv.org/abs/physics/0207027>);
- The model of elementary particles, as superposition of sub-elementary particles and sub-elementary antiparticles, forming the triplets. Consequently, the matter and antimatter in our model are unified on sub-elementary level;
- New Hierarchic theory of liquids and solids, verified on examples of water and ice by computer simulations (<http://arXiv.org/abs/physics/0102086>);
- New Hierarchic model of elementary act of consciousness, based on exchange interaction between microtubules of distant neurons by means of coherent IR photons, inducing the reversible [gel \rightleftharpoons sol] transition in cytoplasm of neuron's body and synaptic reorganization (<http://arXiv.org/abs/physics/0003045>);
- Introducing the concept of Virtual Replica (VR) of matter and living organisms in Bivacuum (phantoms), as a consequence of our Unified model (UM) (<http://arXiv.org/abs/physics/0103031>);
- The specific quantum and neurodynamics processes, responsible for 'Psi field';
- The role of local, nonlocal and distant Bivacuum mediated quantum phenomena, including formation of standing virtual pressure waves (VPW $^{\pm}$), spin waves (VirSW) and quantum teleportation in Mind-Matter and Mind-Mind interaction;
- The new approach to problem of real and virtual time. Its relation to Principle of least action, electromagnetism and gravitation;
- The ability of the Solar system Virtual Replica (SVR) and the Earth one, as part of SVR, to act as a quantum supercomputer, memorizing the past and extrapolating the future.

Unified Model (UM) represents the next stage of our efforts for unification of vacuum, matter, fields and time from few ground postulates. New concept of Bivacuum is introduced, as a dynamic cell-type matrix of the Universe with superfluid and nonlocal properties, composed from *microscopic* sub-quantum particles of the opposite energies, separated by energetic gap. We proceed from the important result of Dirac's theory, pointing to equal probability of positive and negative energy in the Universe. The collective quantum excitations of *sub-quantum particles and antiparticles* form the correlated pairs [*actual* rotor (V^+) + *complementary* antirotor (V^-)], which represent *mesoscopic double cells-dipoles*. The dimensions of sub-quantum particles are supposed to be less, than Plank length (10^{-33} cm) (see Neil's Boid site:

www.rialian.com/rnboyd/).

The notions of quantum mechanics became applicable after collective excitations of subquantum particles acquire the ability to form a standing waves, like Bivacuum rotors and antirotors.

The *macroscopic* structure of Bivacuum is formed by the infinitive number of cells-dipoles, unified in form of virtual Bose condensate (VirBC) with nonlocal properties, due to their infinitive external translational de Broglie wave length. The rotor (V^+) and antirotor (V^-) of cell-dipoles have the opposite quantized energy, virtual mass, spin, charge and magnetic moments.

In symmetric *primordial* Bivacuum, i.e. in the absence of matter and fields, the absolute values of all these parameters in each dipole are equal. The radiuses of *primordial* rotor and antirotor are equal to Compton radius vortex: $[L^+ = L^- = L_0 = \hbar/m_0c]_{1,2,3}^i$, where m_0^i is the rest mass of the electrons of three leptons generation ($i = e, \mu, \tau$).

Such a cells-dipoles are named Bivacuum fermions ($BVF^\uparrow = \mathbf{V}^+ \uparrow \uparrow \mathbf{V}^-$) and Bivacuum antifermions ($BVF^\downarrow = \mathbf{V}^+ \downarrow \downarrow \mathbf{V}^-$). Their opposite half integer spins $S = \pm \frac{1}{2}\hbar$, notated as (\uparrow and \downarrow), depend on direction of clockwise or anticlockwise rotation of pairs of [rotor (\mathbf{V}^+) + antirotor (\mathbf{V}^-)], forming them. Bivacuum bosons ($BVB^\pm = \mathbf{V}^+ \uparrow \downarrow \mathbf{V}^-$) represent the intermediate state between BVF^\uparrow and BVF^\downarrow .

In *secondary* Bivacuum, in presence of matter and fields, the properties of rotors and antirotors do not compensate each other and BVF^\uparrow and BVB^\pm turns to asymmetric. In such a conditions they acquire very small, but nonzero mass, momentum and charge.

Virtual particles and antiparticles in our model are the result of certain combinations of virtual clouds ($\mathbf{VC}_{j,k}^+ \sim V_j^+ - V_k^+$)ⁱ and anti clouds ($\mathbf{VC}_{j,k}^- \sim V_j^- - V_k^-$)ⁱ, composed from sub-quantum particles. Virtual clouds and anti clouds emission/absorption represents a correlated transitions between different excitation states (j, k) of rotors ($V_{j,k}^+$)ⁱ and antirotors ($V_{j,k}^-$)ⁱ of Bivacuum dipoles [BVF^\uparrow]ⁱ and [BVB^\pm]ⁱ. Three generation of Bivacuum fermions correspond to three lepton generation ($i = e, \mu, \tau$).

The process of [*creation* \rightleftharpoons *annihilation*] of virtual clouds is accompanied by oscillation of *virtual pressure* (VP^\pm) in form of *positive and negative virtual pressure waves* (VPW^+ and VPW^-), forming in certain conditions the autowaves in Bivacuum with properties of active medium.

In primordial Bivacuum the virtual pressure waves: VPW^+ and VPW^- , emitted/absorbed in a course of exchange interaction between [BVF^\uparrow and BVF^\downarrow]ⁱ of opposite spins, totally compensate each other. However, in asymmetric secondary Bivacuum, in presence of matter and fields such a compensation of virtual clouds ($\mathbf{VC}_{j,k}^+$) and anti clouds ($\mathbf{VC}_{j,k}^-$) with positive [\cup] or negative [\cap] angular moments (spins) is perturbed and the resulting pressure of virtual particles or antiparticles becomes nonzero.

In contrast to real particles, the virtual ones may exist only in the wave [W] phase, but not in corpuscular [C] phase (see Section 3). It is a reason, why [VPW^\pm] and their superposition in form of the virtual autowaves do not obey the laws of relativist mechanics and causality principle.

The correlated **virtual Cooper pairs** of Bivacuum fermions (BVF) with opposite spins ($S = \pm \frac{1}{2}\hbar$) :

$$[\mathbf{BVF}^\uparrow \bowtie \mathbf{BVF}^\downarrow]_{S=0} \equiv [(\mathbf{V}^+ \uparrow \uparrow \mathbf{V}^-) \bowtie (\mathbf{V}^+ \downarrow \downarrow \mathbf{V}^-)]_{S=0} \quad 5.1$$

Such pairs are bosons and have a properties of massless *Goldstone bosons* with zero spin: $S = 0$.

Superposition of their virtual clouds ($\mathbf{VC}_{j,k}^\pm$), emitted and absorbed in a course of correlated transitions of [$\mathbf{BVF}^\uparrow \bowtie \mathbf{BVF}^\downarrow$]^{j,k} between (j) and (k) sublevels compensate the virtual energy of each other - totally in primordial Bivacuum and partly in secondary Bivacuum. The latter case is a reason for the excessive virtual pressure origination:

$$\Delta \mathbf{VP}^\pm = |\mathbf{VP}^+ - \mathbf{VP}^-| \sim |\mathbf{VC}_{j,k}^+ - \mathbf{VC}_{j,k}^-|_{S=0} \geq 0 :$$

$$(BVF^\uparrow)^{j,k} \equiv (\mathbf{V}^+ \uparrow \uparrow \mathbf{V}^-)^{j,k} \quad 5.2$$

$$\Downarrow \quad \Leftrightarrow \quad |(\mathbf{VC}_{j,k}^+)^{\cup} - (\mathbf{VC}_{j,k}^-)^{\cup}|_{S=0}^{j,k} \geq 0$$

$$(BVF^\downarrow)^{j,k} \equiv (\mathbf{V}^+ \downarrow \downarrow \mathbf{V}^-)^{j,k} \quad 5.3$$

The Goldstone modes in Bivacuum is a result of collective excitations of system of virtual bosons $[BVF^\uparrow \bowtie BVF^\downarrow]_{S=0}$. The energy distribution in a system of weakly interacting bosons (ideal gas), described by Bose-Einstein statistics, do not work for *Goldstone bosons* of Bivacuum due to strong coupling of pairs of $[BVF^\uparrow \bowtie BVF^\downarrow]_{S=0}$, forming virtual Bose condensate (VirBC) with nonlocal properties.

Each of Bivacuum fermions, forming Goldstone bosons, has a properties of *Goldstone fermions (Goldstino)*. In the absence of Bivacuum supersymmetry breach (in primordial Bivacuum), the BVF^\uparrow and BVF^\downarrow are the massless neutral particles.

In secondary Bivacuum, when supersymmetry is broken under the influence of external fields, the repulsion between BVF^\uparrow of the same spins is a consequence of Pauli principle action, based, in accordance to our UM, on the effect of excluded volume, induced by simultaneous emission of virtual clouds (\mathbf{VC}^\uparrow), as a result of their in-phase $[C \rightarrow W]$ transitions.

In secondary Bivacuum, i.e. in presence of matter and fields, their external group velocity ($\mathbf{v} \geq \mathbf{0}$), inertial mass and resulting charge becomes nonzero (<http://arXiv.org/abs/physics/0207027>). The corresponding de Broglie wave length, which determines the dimensions of virtual Bose condensate, is equal to:

$$\lambda_{\text{virBC}} = \frac{\mathbf{h}}{\mathbf{m}_c^+ \mathbf{v}^2 / \mathbf{c}} \leq \infty \quad 5.3a$$

In accordance to our models of Bivacuum, this length, which determines the region of nonlocality, is infinitive in primordial Bivacuum, and has the huge cosmic scale in secondary Bivacuum (<http://arXiv.org/abs/physics/0207027>).

This means, that the *Pauli repulsion* between the BVF^\uparrow of parallel spins may be realized on very big distances, determined by linear dimensions of domains of virtual Bose condensate (VirBC), formed by **2D virtual sheets, composed by Bivacuum fermions** with opposite spins, forming *virtual Cooper pairs*: $[BVF^\uparrow \bowtie BVF^\downarrow]_{S=0}$ in Bivacuum (eq. 5.3a).

The interaction between such domains depends on their boarding conditions.

Changing the dimensions of VirBC domains by increasing or decreasing of Bivacuum symmetry shift, which determines the space curvature, could be used for regulation of attraction - repulsion forces equilibrium in Bivacuum.

The optimal relative orientation of spins of Bivacuum fermions (BVF) in the case of spin-spin interaction, providing the attraction, is the antiparallel one. The parallel spin orientation provides the repulsion in accordance to Pauli principle. The spin-spin exchange interaction in a system of BVF^\uparrow may contribute to the energy of zero-point oscillation of Bivacuum.

The energy distribution in a system of weakly interacting fermions (ideal gas of fermions), described by Fermi-Dirac statistics, do not work for Bivacuum fermions (BVF^\uparrow) in Bivacuum, where they are strongly correlated.

The important role in quantum entanglement and nonlocal interaction, providing formation of Psi-channel between Sender [S] and Receptor [R], plays the exchange spin-spin interaction between Bivacuum fermions. This kind of quantum exchange interaction between BVF^\uparrow and BVF^\downarrow is a result of two principles action: *the identity principle and Pauli principle*. The Pauli principle is responsible for repulsion of fermions with similar spin orientation in the volumes with radius, less than de Broglie wave length of these fermions.

5.1 Creation of sub-elementary particles & antiparticles

The sub-elementary *fermions and antifermions* (\mathbf{F}_\uparrow^+ and \mathbf{F}_\uparrow^-) of the opposite charge (+/-) and energy emerge due to stable symmetry violation between the *actual* (V^+) and *complementary*

(V^-) rotors of BVF^\dagger cells-dipoles: $[BVF^\dagger \rightarrow \mathbf{F}_\dagger^\pm]$. Such a stability of symmetry shift corresponds to realization of Golden mean conditions $[\phi = 0.618 = (\mathbf{v}^\phi/c)^2]$, when the difference between the *rotating* kinetic energies of the actual and complementary states is equal to the energy of rest mass (m_0c^2) of sub-elementary particles:

$$(|m_C^+c^2| - |m_C^-c^2|)_{rot}^\phi = m_0c^2 \quad 5.3b$$

The spatial image of [C] phase of sub-elementary particle (Fig.5.1) represents the [actual rotor + complementary vortex] dipole, corresponding to the [actual mass (m_C^+) + complementary mass (m_C^-)] dipole (<http://arXiv.org/abs/physics/0207027>).

The spatial image of [W] phase in form of cumulative virtual cloud (CVC) of sub-quantum particles is a parted hyperboloid (<http://arXiv.org/abs/physics/0207027>).

The sub-elementary particles: *fermions and antifermions* (\mathbf{F}_\dagger^+ and \mathbf{F}_\dagger^-) of the opposite charge (+/-) and energy, composing the matter, emerge due to stable symmetry violation between the actual (V^+) and complementary (V^-) rotors of BVF^\dagger cells-dipoles: $[BVF^\dagger \rightarrow \mathbf{F}_\dagger^\pm]$ (Fig. 5. 1).

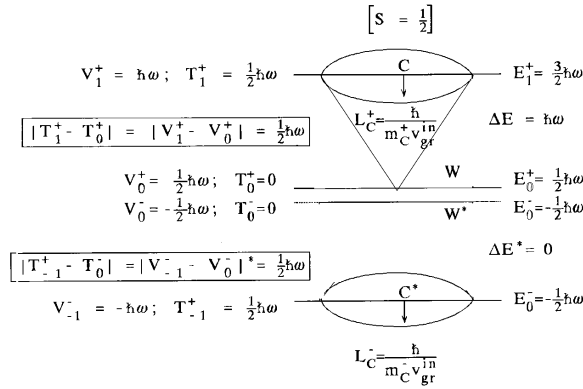

Fig.5.1. The spatial image of [C] phase of sub-elementary particle in form of [actual rotor + complementary vortex] dipole, corresponding to the [actual mass (m_C^+) + complementary mass (m_C^-)] dipole (<http://arXiv.org/abs/physics/0207027>).

5.2 Formation of elementary particles from sub-elementary particles

The coherent triplet of two sub-elementary fermions and one sub-elementary antifermion: $\langle [\mathbf{F}_\dagger^- \times \mathbf{F}_\dagger^+] + \mathbf{F}_\dagger^+ \rangle^{e^+}$ and triplet of two sub-elementary antifermion and one sub-elementary fermion: $\langle [\mathbf{F}_\dagger^+ \times \mathbf{F}_\dagger^-] + \mathbf{F}_\dagger^- \rangle^{e^-}$ represent the positron and electron, correspondingly.

The absolute values of energy of sub-elementary particles/antiparticles in triplets are equal and determined presumably by energy of *uncompensated* $[\mathbf{F}_\dagger^\pm]$. Certain combinations of such triplets from e , μ and τ electrons and positrons form u , d quarks and photons (<http://arXiv.org/abs/physics/0207027>).

In case of photons, the properties, like mass, charge, except spins, of three sub-elementary particles are compensated by properties of three sub-elementary antiparticles.

Consequently, in our UM the matter and antimatter are unified on sub-elementary level, providing stability of elementary particles and antiparticles.

The in-phase $[C \rightleftharpoons W]$ pulsation of pairs $[\mathbf{F}_\dagger^- \times \mathbf{F}_\dagger^+]$ of triplets provides the dynamic exchange interaction of elementary particles with Bivacuum and modulation of Bivacuum *virtual pressure waves* (VPW^+ and VPW^-).

The structure of triplets is stabilized by exchange of virtual clouds of sub-quantum particles between two sub-elementary fermions or antifermions of the opposite spins: $[\mathbf{F}_\dagger^+]$ and \mathbf{F}_\dagger^+ or $[\mathbf{F}_\dagger^-]$ and \mathbf{F}_\dagger^- in a course of their *counterphase* pulsation.

Stabilization of pair of sub-elementary fermion and antifermion of mirror symmetry $[\mathbf{F}_\dagger^- \times \mathbf{F}_\dagger^+]$ or $[\mathbf{F}_\dagger^+ \times \mathbf{F}_\dagger^-]$, pulsing in-phase, occur due to minimization of local Bivacuum

energy/symmetry shift, reflecting the spatially localized energy conservation. The pulsation of these pair and uncompensated sub-elementary particle are counterphase. However, their energy, mass, charge are strictly interrelated (virtually the same) and dictated by the uncompensated $\mathbf{F}_{\dagger}^{\pm}$.

The orientation of sub-elementary particles/antiparticles in triplets is normal to each other. The external dimensionality of sub-elementary particles/antiparticles is supposed to be equal to [1] in contrast to their internal dimensionality, equal to [3]. This fact can be responsible for three dimensional properties of the actual matter and space.

For the other hand, it means that each triplet of sub-elementary particles/antiparticles have 9 internal dimensions and 3 external spatial dimensions.

Asymmetric double cells in form of [vortex + rotor] dipoles or sub-elementary particles, forming elementary particles, get the ability to move as respect to symmetric ones with external group velocity $v_{gr}^{ext} > 0$. The pulsation between such asymmetric (excited) and former symmetric (ground) shape of double cells represents, in accordance to our Unified model, the [corpuscle (C) \rightleftharpoons wave (W)] transitions. These transitions are accompanied by jump-way propagation of triplets of asymmetrically excited double cells in certain combinations, representing elementary particles.

The existence of different 3D structures of virtual autowaves, formed by VPW^{\pm} , modulated by external EM, gravitational fields and matter dynamics, are also the important feature of secondary Bivacuum. The notion of *Virtual Replica (VR)* of condensed matter is introduced,¹⁷ as a multidimensional standing VPW^{\pm} , forming the autowaves in Bivacuum under the influence of hierarchy of matter quantum and molecular dynamics.

5.3 Two Conservation Rules for Bivacuum Fermions (BVF^{\dagger}) and sub-Elementary Particles ($\mathbf{F}_{\dagger}^{\pm}$), as a Mass, Magnetic and Electric Dipoles of Bivacuum

Two internal conservation rules, responsible for stability of BVF^{\dagger} and **sub-elementary** particles and antiparticles (\mathbf{F}_{\dagger}^{+} and \mathbf{F}_{\dagger}^{-}), forming elementary particles of all three generations ($i = e, \mu, \tau$), are postulated in our Unified Model (UM).

I. Conservation rule of the actual and complementary internal kinetic energies of vortex and antivortex: V^{+} and V^{-} of $BVF^{\dagger} = [V^{+} \updownarrow V^{-}]^i$ and their asymmetric vortex and rotor states of $F_{\dagger}^{\pm} = [V^{+} \updownarrow V^{-}]^{i*}$, correspondingly, in form of equality of modules of the internal actual $|2T_{kin}^{+}|^{in}$ and complementary $|-2T_{kin}^{-}|^{in}$ kinetic energies to the rest mass energy (m_0c^2):

$$\left[|2T_{kin}^{+}|^{in} = |m_C^{+}|(v_{gr}^{in})^2 = |-2T_{kin}^{-}|^{in} = |-m_C^{-}|(v_{ph}^{in})^2 = m_0c^2 = const \right]^i \quad 5.4$$

where the product of *internal* group (v_{gr}^{in}) and phase (v_{ph}^{in}) velocities is equal to product of *external* group ($v_{gr} \equiv v_{gr}^{ext}$) and phase ($v_{ph} \equiv v_{ph}^{ext}$) velocities of sub-elementary particle in composition of elementary particle:

$$v_{gr}^{in}v_{ph}^{in} = v_{gr}v_{ph} = c^2 \quad 5.5$$

From (5.4), taking into account (5.5), we get for the ratio of complementary (m_C^{-}) and actual (m_C^{+}) mass of sub-elementary particle:

$$\frac{|m_C^{-}|}{|m_C^{+}|} = \left[\frac{v_{gr}^{in}}{v_{ph}^{in}} \right]^2 = \left[\frac{(v_{gr}^{in})^2}{c^2} \right]^2 \quad 5.6$$

The resulting internal momentum of sub-elementary fermion squared ($P_0^2 = m_0^2 c^2$) is permanent and equal to Compton's one:

$$P_0^2 = P^+P^- = (m_C^+ v_{gr}^{in})(|-m_C^-| v_{ph}^{in}) = (m_C^+ v_{gr})(|-m_C^-| v_{ph}) = 5.7$$

$$= m_0^2 c^2 = \frac{\hbar^2}{L_0^2} = const; \quad P_0 = m_0 c = m_0 \omega_0 L_0 \quad 5.7a$$

where the permanent resulting radius of sub-elementary particle, as a [vortex + rotor] dipole is equal to Compton vorticity radius, determined by particle's rest mass (m_0):

$$L_0 = \frac{\hbar^2}{m_0 c} = (L^+ L^-)^{1/2} \quad 5.8$$

where for each sub-elementary particle, the radius of actual vortex is $L^+ = \hbar/(m_C^+ v_{gr}^{in}) = \hbar/P^+$ and the radius of complementary rotor: $L^- = \hbar/(|-m_C^-| v_{ph}^{in}) = \hbar/P^-$.

As far from (5.4) we have:

$$(2T_k^+)^{in} = \frac{(P^+)^2}{m_C^+} = (2T_k^-)^{in} = \frac{(P^-)^2}{|-m_C^-|} = m_0 c^2 \quad 5.9$$

we get for the ratio of cross section of the actual vortex [$S^+ = \pi(L^+)^2$] and complementary rotor [$S^- = \pi(L^-)^2$]:

$$\frac{S^+}{S^-} = \frac{\pi(L^+)^2}{\pi(L^-)^2} = \frac{(P^-)^2}{(P^+)^2} = \frac{|-m_C^-|}{m_C^+} = 1 - (v/c)^2 \quad 5.10$$

where, in accordance to our model: $|-m_C^-| = m_0[1 - (v/c)^2]^{1/2}$ and $m_C^+ = m_0/[1 - (v/c)^2]^{1/2}$

In *primordial Bivacuum*, when sub-elementary particles F_{\ddagger}^{\pm} are absent, the properties of rotors and antirotors of BVF^{\ddagger} are characterized by equalities:

$$m_C^+ = |-m_C^-| = m_0 \quad 5.10a$$

$$v_{gr}^{in} = v_{ph}^{in} = c$$

$$(2T_k^+)^{in} = (2T_k^-)^{in} = (2T_k^0) = P_0^2/m_0 \quad 5.10b$$

$$where : P_0 = m_0 \omega_0 L_0 = m_0 c \quad 5.10c$$

In slightly asymmetric *secondary Bivacuum* in presence of matter and fields, the equalities (5.10a) for BVF^{\ddagger} are perturbed or broken.

II. Conservation of the absolute values of the internal actual (μ_+) and complementary (μ_-) magnetic moments of vortex and antivortex: V^+ and V^- of Bivacuum fermions:

$BVF^{\ddagger} = [V^+ \uparrow V^-]^i$ and their asymmetric states: vortex and rotor of sub-elementary particles:

$F_{\ddagger}^{\pm} = [V^+ \uparrow V^-]^{i*}$, correspondingly, in form of the equality of their modules to the Bohr magneton (μ_B^{\pm}):

$$|\pm\mu_+| \equiv \frac{1}{2}|e_+| \frac{|\pm\hbar|}{|m_C^+| v_{gr}^{in}} = |\pm\mu_-| \equiv \frac{1}{2}|-e_-| \frac{|\pm\hbar|}{|-m_C^-| v_{ph}^{in}} = \mu_B \equiv \frac{1}{2}|e| \frac{\hbar}{m_0 c} = const \quad 5.11$$

where: e_+ and e_- are the *internal* electric charges of actual vortex and complementary rotor, correspondingly; $|e|$ is a module of the resulting charge of the electron or positron.

The parameters: $|e_{\pm}|$, $|m_C^{\pm}|$ and v_{gr}^{in} are not permanent, in contrast to magnetic moments: $|\pm\mu_+| = |\pm\mu_-| = \mu_B$ and ratios:

$$\frac{|e_+|}{|m_C^+| v_{gr}^{in}} = \frac{|-e_-|}{|-m_C^-| v_{ph}^{in}} = const \quad 5.11a$$

Such a difference between variable electric and permanent magnetic charges of Bivacuum explains the absence of MONOPOLE in Nature (see also eqs. 5.31 and 5.31a).

For the case of *primordial Bivacuum* (in the absence of matter and fields), when $v = v^{ext} = 0$ and $v_{gr}^{in} = v_{ph}^{in} = c$, we have from (5.10) and (5.11) for BVF[†]:

$$|m_C^+| = |-m_C^-| = m_0 \quad 5.12$$

$$|e_+| = |e_-| = e \quad 5.12a$$

$$v_{gr}^{in} = v_{ph}^{in} = c \quad 5.12b$$

$$|\pm\mu_+| = |\pm\mu_-| = \mu_B = const \quad 5.12c$$

In slightly asymmetric *secondary Bivacuum* in presence of matter and fields, the equalities (5.12-5.12b) for BVF[†] are broken, however 5.12c remains unchanged, as well, as for sub-elementary particles.

The resulting magnetic moments of sub-elementary fermion/antifermion (μ_F^\pm), equal to the Bohr's magneton (μ_B), we get, as the actual $|\mu_+|$ and complementary $|\mu_-|$ components product average:

$$\mu_F^\pm = (|\mu_+||\mu_-|)^{1/2} = \left[\left(\frac{|e|}{m_0 c} \right)^2 \frac{\hbar^2}{4} \right]^{1/2} = \frac{|e|\hbar}{m_0 c} \frac{1}{2} = \mu_B = const \quad 5.13$$

where: $|e|^2 = |e_+e_-|$

For the other hand, the well known formula for the *normal* spin magnetic moment of the electron is:

$$\mu_S = \frac{e}{m_0 c} \mathbf{S} \quad 5.14$$

where: $[e/m_0 c]$ is gyromagnetic ratio of the electron.

It follows from our model, that: $\mu_F^\pm = \mu_B = \mu_S^\pm$. Consequently, from eqs. (5.13 and 5.14) we get the value of the electron's spin and definition of the Plank constant, leading from our model of sub-elementary particles:

$$\mathbf{S} = \pm \frac{1}{2} \hbar \quad 5.15$$

$$where: \pm \hbar = \pm \sqrt{|m_C^+||i^2 m_C^-|(v_{gr}^{in} v_{ph}^{in})(L^+ L^-)} = \pm \sqrt{m_0^2 c^2 L_0^2} \quad 5.16$$

From (5.11) we get, that the *internal resulting electric dipole* (\mathbf{d}_{el}^{in}) of sub-elementary particles/antiparticles are related to that of magnetic dipole and the Bohr magneton, as:

$$|\mathbf{d}_{el}^{in}| = [(|e_+||\mathbf{L}^+|)(|-e_-||\mathbf{L}^-|)]^{1/2} = eL_0 = 2|\mu_F^\pm| = 2\mu_B \quad 5.17$$

On the distance $r \gg L_0 = \frac{\hbar}{m_0 c}$, the electric and magnetic dipole radiations, emitted in a course of in-phase $[C \rightleftharpoons W]$ pulsation of sub-elementary particles or antiparticles should be equal, in accordance with existing theory of dipole radiation.

5.2 The Actual & Complementary Mass and Charge Compensation Principles.

Extension of the Einstein's and Dirac's formalism for free relativistic particles

From (5.4 and 5.5) follows the *actual* (m_C^+) & *complementary* ($-m_C^- = i^2 m_C^-$) *mass compensation principle*:

$$|m_C^+||i^2 m_C^-| = m_0^2 \quad 5.18$$

$$or : |m_C^+ m_C^-| = m_0^2 \quad 5.18a$$

where actual (inertial) and complementary (inertialess) mass have the opposite relativist dependence on the external group velocity:

$$|m_C^+| = m_0/[1 - (v/c)^2]^{1/2} \quad 5.19$$

$$|m_C^-| = m_0[1 - (v/c)^2]^{1/2} \quad 5.19a$$

From the ratio of (5.19a) to (5.19), we get the formula, similar to (5.10):

$$\frac{|m_C^-|}{|m_C^+|} = 1 - (v/c)^2 = \frac{S^+}{S^-} \quad 5.20$$

The eqs. 5.19 and 5.19a can be transformed to following shape:

$$(E_C^+)^2 = (m_C^+)^2 c^4 = m_0^2 c^4 + (m_C^+ v)^2 c^2 \quad 5.21$$

$$(E_C^-)^2 = (m_C^-)^2 c^4 = m_0^2 c^4 - (m_0 v)^2 c^2 \quad 5.21a$$

where: E_C^+ and E_C^- are the actual and complementary energy of wave B, correspondingly.

The first eq. (5.21) coincides with those, obtained by Dirac. The second (5.21a) for complementary energy is a new one and reflects the generalization of special theory of relativity and Dirac's theory for relativist particles.

From (5.11; 5.5a and 5.18) follows the internal *actual & complementary charge compensation principle*, symmetric to *mass compensation principle*:

$$|e_+| |i^2 e_-| = [i^2 e]^2 \quad 5.22$$

$$\text{or : } |e_+ e_-| = (e)^2 \quad 5.22a$$

The positive *actual* and negative *complementary* internal negative charges: $[e_+]$ and $[i^2 e_-]$, correspond to *vortex* and *rotor* of sub-elementary fermions.

One can see, that the rest mass squared (2.7) and resulting charge squared (2.11a) are not dependent on the external group velocity (v), i.e. they are relativist invariants.

5.4 The Relation Between the External and Internal Parameters of Elementary Particles

Combining (5.20 and 5.6), we get the formula for unification of the internal (\mathbf{v}_{gr}^{in}) and external group ($\mathbf{v}_{gr}^{ext} \equiv \mathbf{v}$) velocities of sub-elementary particles, as the asymmetric Bivacuum dipoles:

$$\frac{c}{\mathbf{v}_{gr}^{in}} = \left(\frac{\mathbf{v}_{ph}^{in}}{\mathbf{v}_{gr}^{in}} \right)^{1/2} = \frac{1}{[1 - (\mathbf{v}/c)^2]^{1/4}} \quad 5.22b$$

Taking into account (5.6; 5.11a and 5.22b) we get the important interrelations between the actual and complementary mass and charge of the asymmetric Bivacuum dipoles and dependence of these parameters ratio on their external group velocity (\mathbf{v}):

$$\left(\frac{m_C^+}{m_C^-} \right)^{1/2} = \frac{m_C^+}{m_0} = \frac{\mathbf{v}_{ph}^{in}}{\mathbf{v}_{gr}^{in}} = \left(\frac{c}{\mathbf{v}_{gr}^{in}} \right)^2 = \frac{|e_+|}{|e_-|} = \left(\frac{e_+}{e} \right)^2 = \frac{1}{[1 - \mathbf{v}/\mathbf{v}_{ph}]^{1/2}} \quad 5.22c$$

one of the consequence of (5.22c):

$$\frac{e_+}{e} = \frac{1}{[1 - \mathbf{v}/\mathbf{v}_{ph}]^{1/4}} \quad 5.22d$$

We can see from (5.22c), that at $\mathbf{v} = 0$, we have the conditions of symmetric Bivacuum double cells-dipoles (BVF), pertinent for primordial Bivacuum in the absence of matter:

$$m_C^+ = m_C^- = m_0; \quad \mathbf{v}_{ph}^{in} = \mathbf{v}_{gr}^{in} = \mathbf{c}; \quad |e_+| = |e_-| = e \quad \text{at} \quad \mathbf{v} = \mathbf{0} \quad 5.22e$$

5.5 Duality, as a Result of Quantum Beats Between the Actual and Complementary States of Sub-elementary Particles, Forming the Elementary Particles

Duality of elementary particles and antiparticles in accordance to Unified model, is a consequence of coherent quantum beats of their sub-elementary particles/antiparticles, as asymmetric Bivacuum dipoles, between two states: the asymmetrically excited state $(BVF^\dagger)^* \equiv \mathbf{F}_\ddagger^+$ and its symmetric state (BVF^\dagger) :

$$\left[\mathbf{F}_\ddagger^+ \stackrel{CVC}{\rightleftharpoons} BVF^\dagger \right]^i \quad 5.23$$

where: i means *three electron's or positron's* generation: $i = e, \mu, \tau$.

These beats are accompanied by [emission \rightleftharpoons absorption] of cumulative virtual cloud (CVC) of sub-quantum particles, representing [W] phase of sub-elementary particle, oscillation of the mass and charge symmetry shift.

As far the energy of symmetric BVF^\dagger is equal to zero, it means that the energy of corpuscular [C] phase, in form of sub-elementary particle $[\mathbf{F}_\ddagger^+]$ is equal to energy of the wave [W] phase, in form of [CVC]: $E_C = E_W$.

The energy of quantum beats in a course of $[C \rightleftharpoons W]$ pulsation of **sub-elementary particle** is equal to difference of energy between the absolute values of actual (vortex) and complementary (rotor) states. We get the energy of sub-elementary de Broglie wave in [C] and [W] phase, its relation to de Broglie wave frequency $(\omega_0 = \omega_{C \rightleftharpoons W})^i$ and the wave length $(\lambda_{C,W})$, equal in both phase, as a sum of rotational and two translational contributions:

$$[E_{C \rightleftharpoons W} = \hbar\omega_{C \rightleftharpoons W} = E_C = E_W]^i = [|m_C^+|c^2 - |m_C^-|c^2]_{tot}^i = [m_C^+ \mathbf{v}_{res}^2]^i \equiv \quad 5.24$$

$$\begin{aligned} [m_C^+ \mathbf{v}^2]^i &= [(m_C^+ \mathbf{v}_{rot}^2)^\phi + m_C^+ \mathbf{v}_{\parallel tr}^2 + m_C^+ \mathbf{v}_{\perp tr}^2]^i = \{ m_C^+ [\mathbf{v}_{rot}^2 + \mathbf{v}_{\parallel tr}^2 + \mathbf{v}_{\perp tr}^2] \}^i = \\ &= [(E_{C,W}^S)_{rot} + (E_{C,W})_{\parallel tr} + (E_{C,W})_{\perp tr}]^i = \end{aligned} \quad 5.24a$$

$$\begin{aligned} &= [|m_C^+ - m_C^-|_{rot}^2 c^2 + |m_C^+ - m_C^-|_{\parallel tr}^2 c^2 + |m_C^+ - m_C^-|_{\perp tr}^2 c^2]^i = \\ &= \left[m_0 \omega_0^2 L_0^2 + \alpha \frac{p_{tr}^2}{m_C^+} + \beta \frac{p_{tr}^2}{m_C^-} \right]^i = [2(T_k)_{rot} + 2(T_k)_{\parallel tr} + 2(T_k)_{\perp tr}]^i = \end{aligned} \quad 5.24b$$

$$= \left[m_0 \omega_0^2 L_0^2 + m_0 c^2 \frac{(\mathbf{v}_{\parallel tr}/c)^2}{[1 - (\mathbf{v}/c)^2]^{1/2}} + m_0 c^2 \frac{(\mathbf{v}_{\perp tr}/c)^2}{[1 - (\mathbf{v}/c)^2]^{1/2}} \right]^i = [\mathbf{E}_S + \mathbf{E}_E + \mathbf{E}_G]^i \quad 5.24c$$

the longitudinal (\parallel) and transversal (\perp) contributions to translational energy of each sub-elementary particle:

$$\left[(E_C = E_W)_{\parallel, \perp, tr} = \frac{\hbar^2}{m_C^+ \lambda_{\parallel, \perp, tr}^2} \right]^i \quad \text{where} : \quad \left[\lambda_{\parallel, \perp} = \frac{\hbar}{m_C^+ \mathbf{v}_{\parallel, \perp, tr}} = \frac{\hbar}{|m_C^+ - m_C^-| c^2 / \mathbf{v}_{\parallel, \perp, tr}} \right]^i \quad 5.25$$

where:

$$p_{\parallel tr} = m_C^+ \mathbf{v}_{\parallel tr} \quad \text{and} \quad p_{\perp, tr} = m_C^+ \mathbf{v}_{\perp, tr} \quad 5.25a$$

are the external longitudinal and transversal translational momentums of particle

the resulting external group velocity, leading from (5.24) and (5.20), is :

$$\mathbf{v}^2 = \mathbf{v}_{rot}^2 + \mathbf{v}_{\parallel tr}^2 + \mathbf{v}_{\perp tr}^2 = \mathbf{c}^2 \phi + \mathbf{v}_{\parallel tr}^2 + \mathbf{v}_{\perp tr}^2 = \mathbf{c}^2 \left(1 - \frac{|m_C^-|}{|m_C^+|} \right) \quad 5.25b$$

where the external rotational velocity of each sub-elementary particle, which determines the value of the rest mass ($m_0 = |m_C^+ - m_C^-|^\phi$) always is equal to that of Golden mean (GM):

$$\mathbf{v}_{rot}^2 = \mathbf{c}^2 \phi$$

The longitudinal ($m_C^+ \mathbf{v}_{\parallel tr}^2$) and transversal ($m_C^+ \mathbf{v}_{\perp tr}^2$) translational contributions to the actual energy of elementary particle (m_C^+)_{rot, tr} \mathbf{v}^2 can be presented, correspondingly, as:

$$m_C^+ \mathbf{v}_{\parallel tr}^2 = \left(\frac{m_0 \mathbf{v}_{\parallel tr}^2}{[1 - (\mathbf{v}/\mathbf{c})^2]^{1/2}} \right) = E_E \quad 5.25c$$

$$m_C^+ \mathbf{v}_{\perp tr}^2 = \left(\frac{m_0 \mathbf{v}_{\perp tr}^2}{[1 - (\mathbf{v}/\mathbf{c})^2]^{1/2}} \right) = E_G \quad 5.25d$$

we can see, that both translational contributions to resulting energy: $\mathbf{E}_{C \rightleftharpoons W} = (\mathbf{m}_C^+)_{rot, tr} \mathbf{v}^2$, which determine the electromagnetic (E_E) and gravitational (E_G) potentials, are tending to zero, at $\mathbf{v}_{\parallel tr}^2 \rightarrow 0$ and $\mathbf{v}_{\perp tr}^2 \rightarrow 0$. For the other hand, the translational acceleration, when $v_{\parallel tr} \rightarrow c$ and $v_{\perp tr} \rightarrow c$ are accompanied by corresponding increasing of the resulting velocity (5.25b) and energy contributions.

The resulting actual energy from (5.24) can be expressed, as a sum of rotational - spin contribution, responsible for the rest mass origination, two translational contribution, responsible for electromagnetic and gravitational interactions:

$$E_{C,W} = (m_C^+)_{res} \mathbf{v}^2 = (m_C^+)_{rot, tr} \mathbf{v}^2 = [\mathbf{E}_S + \mathbf{E}_E + \mathbf{E}_G]^i = m_0 \omega_0^2 L_0^2 + \frac{m_0 \mathbf{v}_{\parallel tr}^2}{[1 - (\mathbf{v}/\mathbf{c})^2]^{1/2}} + \frac{m_0 \mathbf{v}_{\perp tr}^2}{[1 - (\mathbf{v}/\mathbf{c})^2]^{1/2}} \quad 5.25e$$

The rotational (spin) contribution to energy is determined by Golden mean conditions, as a resonant conditions of the exchange interaction elementary particles with Bivacuum:

$$\left[(E_{C,W}^S)_{rot} = [m_C^+ \mathbf{v}_{rot}^2]^\phi = m_0 c^2 = \hbar \omega_0 = m_0 \omega_0^2 L_0^2 = \frac{p_0^2}{m_0} = \frac{\hbar^2}{m_0 L_0^2} \right]^i \quad 5.26$$

where the rest mass ($m_0 = |m_C^+ - m_C^-|^\phi$) is determined by difference of the actual vortex mass $|m_C^+|^\phi = m_0/\phi$ and complementary rotor mass $|m_C^-| = \phi m_0$ at Golden mean (GM) conditions $[(\mathbf{v}/\mathbf{c})^2 = \phi = 0.618$, see section 4.2 at <http://arXiv.org/abs/physics/0207027>]; the momentum of rotation, equal to spin momentum of Cumulative virtual clouds (CVC[↑] or CVC[↓]), corresponding to [W] phase of particles: $p_0 = m_0 \omega_0 L_0 = m_0 c$.

The rotational group velocity at GM conditions is $\mathbf{v}_{rot}^\phi = c \phi^{1/2}$; the frequency of $[C \rightleftharpoons W]$ pulsation for each of ($i = e, \mu, \tau$) generation of elementary particles is: $\omega_{C \rightleftharpoons W}^i = [m_C^+ \mathbf{v}_{res}^2]^i / \hbar$; the resulting Compton radius of sub-elementary particle is $L_0 = (L_+ L_-)^{1/2} = \hbar / m_0 c$.

The *resulting external group velocity* of particle ($\mathbf{v}_{res} \equiv \mathbf{v}$), taking into account its spinning and translational dynamics, is determined by the ratio of resulting actual and complementary masses from (5.20 and 5.25b):

$$\mathbf{v}_{res} \equiv \mathbf{v} = (\mathbf{v}_{rot}^2 + \mathbf{v}_{\parallel tr}^2 + \mathbf{v}_{\perp tr}^2)^{1/2} = c \left[1 - \left| \frac{m_C^-}{m_C^+} \right| \right]^{1/2} \quad 5.26a$$

- the translational contribution to the total energy of particle is a sum of longitudinal (\parallel, tr) and transversal (\perp, tr) components:

$$(E_{C,W})_{tr} = (E_{C,W})_{\parallel tr} + (E_{C,W})_{\perp tr} = \alpha m_C^+ \mathbf{v}^2 + \beta m_C^+ \mathbf{v}^2 \quad 5.26b$$

$$= m_C^+ \mathbf{v}_{\parallel}^2 + m_C^+ \mathbf{v}_{\perp}^2 = \mathbf{E}_E + \mathbf{E}_G$$

Two external **translational** (\parallel and \perp) momentums of triplets $\langle [\mathbf{F}_{\uparrow}^- \bowtie \mathbf{F}_{\downarrow}^+] + \mathbf{F}_{\uparrow}^{\pm} \rangle$ of particles:

$$p_{\parallel, \perp} = m_C^+ \mathbf{v}_{\parallel, \perp} = m_0 \mathbf{v}_{\parallel, \perp} / [1 - (\mathbf{v}/c)^2]^{1/2} \quad 5.26c$$

are subdivided to longitudinal (\parallel) and transversal (\perp) ones, as respect to particle's resulting external momentum; $\mathbf{v}_{\parallel tr}$ is a longitudinal group velocity of particle's vibrations, induced by oscillation of momentum of uncompensated sub-elementary particle $\mathbf{F}_{\uparrow}^{\pm}$, accompanied its $[C \rightleftharpoons W]$ pulsation (see 5.30a); $\mathbf{v}_{\perp tr}$ is a transversal group velocity of particle's vibrations, induced by oscillation of resulting momentum of pair $[\mathbf{F}_{\uparrow}^- \bowtie \mathbf{F}_{\downarrow}^+]$, accompanied its $[C \rightleftharpoons W]$ coherent pulsation (see 5.30c).

It is important to note, that:

$$\mathbf{v}_{rot} \gg \mathbf{v}_{\parallel tr} \gg \mathbf{v}_{\perp tr} \quad \text{and} \quad 5.27$$

$$(E_{C,W}^S)_{rot} \gg (E_{C,W})_{\parallel tr} \gg (E_{C,W})_{\perp tr}$$

The set of these expressions, in fact, unify the extended special theory of relativity with quantum mechanics, elucidating the fundamental root of quantum physics: corpuscle - wave duality of particles.

Our dynamic presentation of duality explains also the elementary particles, as a permanent sources of electromagnetic and gravitational potentials. The source of potential energy is a permanent energy redistribution between the negative and positive realms of secondary Bivacuum in a course of $[C \rightleftharpoons W]$ pulsation of particles, as a mass, electric and magnetic dipoles (<http://arXiv.org/abs/physics/0207027>).

5.6 Quantum Roots of Golden Mean (GM)

It was shown (Kaivarainen, 1993; 1995; 2002a), that the quantum roots of the famous Golden mean, so widely used in Nature (see huge site of Dan Winter: <http://www.soulinvitation.com/indexdw.html>), are related to conditions of *Hidden Harmony: equality of the internal (in) and external (ext) group and phase velocities of each sub-elementary particle*:

$$[\mathbf{v}_{gr}^{in} = \mathbf{v}_{gr}^{ext} \equiv \mathbf{v}_{gr}] \quad \text{and} \quad [\mathbf{v}_{ph}^{in} = \mathbf{v}_{ph}^{ext} \equiv \mathbf{v}_{ph}] \quad 5.27a$$

$$\text{at : } \mathbf{v}_{gr}^{in} \mathbf{v}_{ph}^{in} = \mathbf{v}_{gr}^{ext} \mathbf{v}_{ph}^{ext} = c^2$$

These Hidden Harmony conditions turns eq.5.22b to simple quadratic equation:

$$\phi^2 + \phi - 1 = 0, \quad \text{leading from : } \phi = \frac{1}{\phi} - 1 \quad \text{or : } \frac{\phi}{(1 - \phi)^{1/2}} = 1 \quad 5.27b$$

$$\text{where : } \phi = \left[\frac{\mathbf{v}}{\mathbf{v}_{ph}} \right]^{ext, in} = \left(\frac{\mathbf{v}^2}{c^2} \right)^{ext, in} = 0.6180339887 \quad \text{(Golden mean)} \quad 5.27c$$

The positive solution of equation (5.27b) is equal to **Golden mean** ($Psi \equiv \phi = 0.6180339887$).

Taking into account (5.27b) formula (5.24) for Hidden Harmony conditions can be transformed to:

$$[|m_C^+|^{\phi} - |m_C^-|^{\phi}]^i = [m_C^+ (\mathbf{v}_{res}^{\phi}/c)^2]^i = \frac{m_0 \phi}{[1 - \phi]^{1/2}} = m_0 \quad 5.27'c$$

It is well known, that Golden mean value is related strongly to *Fibonacci series*:

$$n = 1, 2, 3, 5, 8, 13, 21, 34, 55, \dots$$

where the value of next term of series is defined as a sum of two antecedent terms.

The bigger is number of series (n_j), the closer is its ratio to the next one ($n_{j+1} = n_j + n_{j-1}$) to Golden mean:

$$\frac{n_j}{n_{j+1}} \rightarrow 0.6180339887 \quad \text{at } j \rightarrow \infty$$

At the Golden mean condition (5.27'c) the formulas for energy ($E_C^\phi = E_W^\phi$), mass $[m_C^+]^\phi$ and $[m_C^-]^\phi$, velocity (\mathbf{v}^ϕ), the *resulting* momentum (P^ϕ) and de Broglie wave radius ($L^\phi = \lambda^\phi/2\pi$) of sub-elementary particle (eq. 5.24 and its parameters) turn to the elegant quantitative relations:

$$\begin{aligned} E_W^\phi &= \hbar\omega_{C \rightleftharpoons W}^\phi = |m_C^+ - m_C^-|^\phi c^2 = m_0 c^2 = m_0 \omega_0^2 L_0^2 = \frac{\hbar^2}{m_0 L_0^2} = & 5.27d \\ &= [m_C^+ \mathbf{v}^2]^\phi = \frac{\hbar^2}{[m_C^+ (L^+)^2]^\phi} = E_C^\phi \end{aligned}$$

$$\text{where : } [m_C^+]^\phi = m_0 (c/\mathbf{v}^\phi)^2 = \frac{m_0}{\phi} \simeq 1.618 m_0;$$

$$[m_C^-]^\phi = \phi m_0 \simeq 0.618 m_0$$

$$\left[\frac{m_0^2}{(m_C^+)^2} \right]^\phi = \left[\frac{m_C^-}{m_C^+} \right]^\phi = \phi^2 = 1 - \phi \simeq 0.382$$

$$\mathbf{v}^\phi = c\phi^{1/2} = 0.786151377 c; \quad \mathbf{v}_{ph}^\phi = \mathbf{c}/\phi^{1/2}$$

$$P^\phi = [m_C^+ \mathbf{v}^2]^\phi / c = m_0 c \equiv P_0; \quad P_0 / (P^+)^{\phi} = \mathbf{v}^\phi / \mathbf{c} = \phi^{1/2}$$

$$L^\phi = L_0 = \hbar / P_0 = \hbar / m_0 c; \quad L_0 / (L^+)^{\phi} = (\lambda^\pm / \lambda^+)^{\phi} = \mathbf{c} / \mathbf{v}^\phi = 1 / \phi^{1/2}$$

where: $(P^+)^{\phi} = m_C^+ \mathbf{v}^\phi$ and $(\lambda^+)^{\phi} = 2\pi(L^+)^{\phi} = h / (m_C^+ \mathbf{v}^\phi)$ are the actual momentum and the actual de Broglie wave length of sub-elementary particle at GM conditions.

For the case of triplets of sub-elementary particles/antiparticles, representing the elementary particles, like electron $\langle [F_{\downarrow}^- \bowtie F_{\downarrow}^+] + F_{\downarrow}^- \rangle^i$, the counterphase $[C \rightleftharpoons W]$ pulsation of uncompensated $F_{\downarrow}^- \rangle^i$ and pair $[F_{\downarrow}^- \bowtie F_{\downarrow}^+]^i$, responsible for interaction of particles with Bivacuum, can be presented, like:

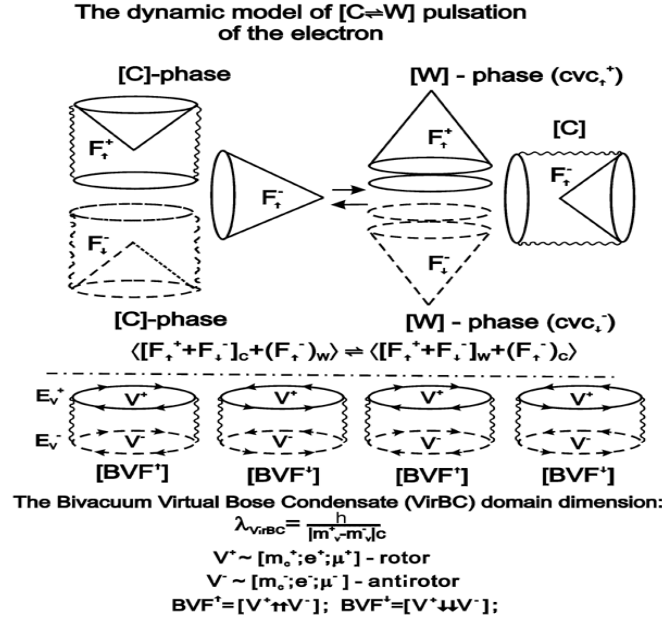

Fig. 5.2. The counterphase [C \rightleftharpoons W] pulsation of uncompensated $F_{\uparrow}^- >$ and pair $[F_{\uparrow}^- \bowtie F_{\uparrow}^+]$ of the electron $\langle [F_{\uparrow}^- \bowtie F_{\uparrow}^+] + F_{\uparrow}^- \rangle$. The properties of $F_{\uparrow}^- >$ determines the real (measurable) properties of particles, its interaction with other particles and fields. The parameters of sub-elementary particle and sub-elementary antiparticle of pairs compensate each other. The properties of $F_{\uparrow}^- >$ and $[F_{\uparrow}^- \bowtie F_{\uparrow}^+]$ are strongly interrelated and affect the symmetry and dynamics of pairs of Bivacuum fermions ($BVF^{\uparrow} \bowtie BVF^{\downarrow}$), forming virtual Bose condensate with nonlocal properties. The in-phase [C \rightleftharpoons W] pulsation of $[F_{\uparrow}^- \bowtie F_{\uparrow}^+]$ is responsible for interaction of particles with Bivacuum and the Virtual replicas of matter creation.

5.7. Compensation principle of Bivacuum symmetry shifts, as a new explanation of fields, generated by elementary particles

The triplets of sub-elementary particles, forming the elementary particles, have some additional properties, as respect to analyzed above isolated sub-elementary particles, making a triplets stable, notwithstanding of their complex dynamics. *The law of energy conservation keeps the total energy of system [elementary particles+secondary Bivacuum] unchanged and equal to zero due to sub-systems energy compensation inside and outside elementary particles.*

The Bivacuum symmetry shift, pertinent for corpuscular [C] phase of each sub-elementary particle, we introduce as a difference between the actual and complementary masses, proportional to the energy of this phase (see 5.24):

$$\Delta m_C(\mathbf{v}) = \Delta m_{C \rightleftharpoons W}(\mathbf{v}) = |m_C^+| - |m_C^-| = m_C^+ \mathbf{v}^2 / c^2$$

where (\mathbf{v}) is the resulting external group velocity of sub-elementary particle (5.26a).

For the wave [W] phase this shift for the end of simplicity we take equal to zero [$\Delta m_W(\mathbf{v}) = \mathbf{0}$], assuming that the difference between circular velocities of the rotor (\mathbf{v}_{gr}^{in}) and antirotor (\mathbf{v}_{ph}^{in}) of the 'anchor' Bivacuum fermion (BVF) after emission of cumulative virtual cloud (CVC) turns to zero, i.e. they becomes equal. In accordance to (5.6), it means, that in the [W] phase $\Delta m_W = 0$. Consequently, we get the equality: $\Delta m_C(\mathbf{v}) = \Delta m_{C \rightleftharpoons W}(\mathbf{v})$. However, we have to keep in mind, that in secondary Bivacuum, i.e. in presence of matter and fields, the ratio $\mathbf{v}_{gr}^{in} / \mathbf{v}_{ph}^{in} \neq 1$, meaning that $\mathbf{v} \geq \mathbf{0}$ for BVF of secondary Bivacuum and, consequently, $\Delta m_W \geq 0$ (see eq. 5.22c).

We can see, from the formula above, that each kind of particle dynamics, related with deviation of external velocity from zero ($\mathbf{v} > \mathbf{0}$), can be characterized by its Bivacuum symmetry shift [$\Delta m_{C \rightleftharpoons W} > 0$]. The [C \rightleftharpoons W] pulsation of particles is accompanied by oscillation of

Bivacuum symmetry shift, equal to:

$$\Delta m_{C \rightleftharpoons W}(\mathbf{v}) = [\Delta m_C(\mathbf{v}) \rightleftharpoons \Delta m_W(\mathbf{v})] \cong [\Delta m_C(\mathbf{v}) \rightleftharpoons 0] = \Delta m_C(\mathbf{v})$$

This Bivacuum symmetry shift oscillation means corresponding oscillation of energy:

$$\Delta m_{C \rightleftharpoons W} c^2 = [m_C^+ - m_C^-] c^2 = m_C^+ \mathbf{v}^2$$

This relation is correct for any kind of particles dynamics: rotational or translational (longitudinal and transversal), related to change of their kinetic energy.

Three kinds of **local** Bivacuum symmetry oscillations, accompanied $[C \rightleftharpoons W]$ pulsation of unpaired sub-elementary particle $F_{\uparrow}^- >^i$ and $[emission \rightleftharpoons absorption]$ of cumulative virtual cloud (CVC), are related to oscillation of:

a) energy of rotation (spinning) of sub-elementary particle, which determines its rest mass energy:

$$E_S = (m_C^+ \mathbf{v}^2)^\phi = m_0 c^2 = m_0 \omega_0^2 L_0^2 ;$$

b) energy of longitudinal translational vibrations, responsible for electromagnetic potential:

$$(E_{C,W})_{\parallel tr} = E_E = \alpha m_C^+ \mathbf{v}^2 = m_C^+ \mathbf{v}_{\parallel tr}^2 ;$$

c) energy of transversal translational vibrations, responsible for gravitational potential:

$$(E_{C,W})_{\perp tr} = E_G = \beta m_C^+ \mathbf{v}^2 = m_C^+ \mathbf{v}_{\perp tr}^2 .$$

The 1st kind of energy/symmetry oscillation, related with *emission* and *absorption* of the biggest part of CVC energy, related with its angular momentum (spin), is totally local and reversible.

For longitudinal (b) and transversal (c) vibrations of $F_{\uparrow}^- >^i$, the *local* mechanism of energy/symmetry reversibility compensation is absent and these energy contributions to that of CVC is radiated in space irreversibly.

The energy conservation law demands, that in such a case the *external* to particle Bivacuum symmetry shifts of Bivacuum Fermions (BVF) should compensate the corresponding local symmetry/energy oscillations.

These spatially delocalized perturbations of Bivacuum represent electromagnetic and gravitational fields, generated by corresponding vibrations of unpaired sub-elementary particle.

Taking this into account, the compensation principle *between the local and distant symmetry/energy shifts of Bivacuum* can be presented as:

$$\sum_{n=1}^{n=N} [\mathbf{E}_E^n (F_{\uparrow}^+)^i + \mathbf{E}_G^n (F_{\uparrow}^+)^i]_{Local} = \quad 5.28$$

$$= - \sum_{k=1}^{k=\infty} [grad \Delta \mathbf{E}_{\mathbf{E}(V^+ \rightleftharpoons V^-)_i}^k + grad \Delta \mathbf{E}_{\mathbf{G}(V^+ \rightleftharpoons V^-)_i}^k]_{Distant} = \quad 5.28a$$

$$= -\beta m_0^i c^2 \frac{\vec{r}}{r} \sum_{k=1}^{k=\infty} grad \ln [K_{\mathbf{E}(V^+ \rightleftharpoons V^-)_i} K_{\mathbf{G}(V^+ \rightleftharpoons V^-)_i}]_{Distant}^k \quad 5.28b$$

where: N is a finite number of charged elementary particles in closed system under consideration; $k = \infty$ is the infinitive number of asymmetric Bivacuum fermions or antifermions, perturbed by elementary particles; $\mathbf{E}_E^n (F_{\uparrow}^+)^i$; $\mathbf{E}_G^n (F_{\uparrow}^+)^i$ are the local electromagnetic and gravitational energy contributions, generated by unpaired sub-elementary particle.

We have to accept, that our perception of macroscopic WORLD is limited by properties of uncompensated sub-elementary particles in corpuscular [C] phase. In this case we have no contradictions of our empirical science with Unified Model (UM). However, in future, the situation may change to better evaluation of [C \rightleftharpoons W] pulsation of triplets of elementary particles and their interaction with Bivacuum.

Parts of eqs. 5.28a and 5.28b represent the sum of two contributions to symmetry shift of sub-elementary particles, induced by translational vibrations (longitudinal and transversal), responsible for electromagnetic and gravitational potentials.

Corresponding two kinds of Bivacuum dipoles equilibrium constants are:

$$K_{\mathbf{E}(V^+ \rightleftharpoons V^-)^i} = \exp \left[-\frac{\Delta \mathbf{E}_{\mathbf{E}(V^+ \rightleftharpoons V^-)^i}^k}{\beta m_0^i c^2} \right] \quad 5.29$$

$$K_{\mathbf{G}(V^+ \rightleftharpoons V^-)^i} = \exp \left[-\frac{\Delta \mathbf{E}_{\mathbf{G}(V^+ \rightleftharpoons V^-)^i}^k}{\beta m_0^i c^2} \right] \quad 5.29a$$

The local and reversible asymmetry, generated by the angular momentum (spin) of sub-elementary particles in [W] phase in form of corresponding part of CVC, is compensated by shift of dynamic equilibrium of Bivacuum fermions with opposite spins ($BVF^\uparrow \rightleftharpoons BVF^\downarrow$).

In this process the equilibrium between properties of rotors and antirotors ($V^+ \rightleftharpoons V^-$)ⁱ keeps unchanged. *This means that the energy of Bivacuum do not change.* In this case the law of energy conservation keeps in force, because $\mathbf{E}_S = m_0 c^2 = m_0 \omega_0^2 L_0^2$, related with the rest mass of unpaired sub-elementary particle $\mathbf{F}_{\uparrow}^\pm$ ⁱ, is reversibly emitted and absorbed in the process of [C \rightleftharpoons W] pulsation. The electromagnetic and gravitational dipole radiation, related to longitudinal and transversal translational vibrations, accompanied [C \rightleftharpoons W] pulsation are locally uncompensated and irreversible.

The periodic longitudinal momentum ($\mathbf{P}_{\parallel tr}$), acting on triplets $\langle [\mathbf{F}_{\downarrow}^+ \bowtie \mathbf{F}_{\uparrow}^-] + \mathbf{F}_{\uparrow}^\pm \rangle^i$, is provided by periodic [emission - absorption] of cumulative virtual cloud (CVC), followed the [C \rightleftharpoons W] pulsation of unpaired sub-elementary particle $\mathbf{F}_{\uparrow}^\pm$ ⁱ of triplets. We assume, that the longitudinal (z, ||) translational vibrations of triplets occur in direction, coinciding with the virtual Pointing vector of EM energy density flux, resulting from electric [E] and magnetic [H] tensions oscillation, accompanied pulsation of $[\mathbf{F}_{\uparrow}^\pm]$ ⁱ:

$$\mathbf{P}_{\mathbf{F}_{\uparrow}^\pm} \equiv \mathbf{P}_{\parallel tr} = [\mathbf{E} \times \mathbf{H}]_{\parallel tr} \quad 5.29$$

Corresponding to (5.29) density of momentum of virtual EM energy for $\mathbf{F}_{\uparrow}^\pm$ we define as:

$$\left(\mathbf{g}_{\parallel} = \frac{1}{c^2} \mathbf{P}_{\parallel tr} = \alpha [m_C^+ - m_C^-]_{\mathbf{F}_{\uparrow}^\pm} c = \alpha m_C^+ v^2 / c = \alpha \frac{\mathbf{p}^2}{m_C^+ c} \right)^i \quad 5.30$$

where $\alpha = e^2 / \hbar c$ is the electromagnetic (EM) fine structure constant; $\mathbf{p} = m_C^+ \mathbf{v}$ is the resulting external momentum.

The periodic transversal momentum, acting on elementary particles, is also provided by periodic [emission - absorption] of cumulative virtual cloud (CVC), followed the [C \rightleftharpoons W] pulsation of unpaired sub-elementary particle $[\mathbf{F}_{\uparrow}^+ \text{ or } \mathbf{F}_{\uparrow}^-]$ of triplets $\langle [\mathbf{F}_{\downarrow}^+ \bowtie \mathbf{F}_{\uparrow}^-] + \mathbf{F}_{\uparrow}^\pm \rangle$.

Corresponding density of transversal momentum of virtual energy, responsible for gravitation, we define as:

$$\left(\mathbf{g}_{\perp} = \frac{1}{c^2} \mathbf{P}_{\perp tr} = \alpha c \left| [m_C^+ - m_C^-]_{\mathbf{F}_{\uparrow}^+ \bowtie \mathbf{F}_{\uparrow}^-}^{\mathbf{F}_{\uparrow}^+} - [m_C^+ - m_C^-]_{\mathbf{F}_{\uparrow}^+ \bowtie \mathbf{F}_{\uparrow}^-}^{\mathbf{F}_{\uparrow}^-} \right| = \beta m_C^+ v^2 / c = \beta \frac{\mathbf{p}^2}{m_C^+ c} \right)^i \quad 5.30c$$

where $\beta = (m_0 / M_{Pl})^2$ is the gravitational fine structure constant, introduced earlier.¹⁷

The virtual quanta emission, responsible for virtual Pointing vector, in accordance with known theory of the electric and magnetic dipole radiation, is a result of electric and magnetic charges acceleration in a course of [C \rightleftharpoons W] pulsation of sub-elementary particles/antiparticles composing elementary particles.

Sub-elementary particles represent asymmetric [rotor+vortex] triple-dipoles: electric, magnetic and mass dipoles (section 5.1) in contrast to 'almost' symmetric Bivacuum fermions

and antifermions (BVF^\uparrow and BVF^\downarrow), as a pairs [rotor + antirotor]. The energy source of $[C \rightleftharpoons W]$ pulsations and radiation is a quantum beats between positive and negative nonequilibrium sublevels of Bivacuum (Kaivarainen, 2002).¹⁷ Each sub-elementary particle in composition of elementary one is a source of virtual spherical waves (electromagnetic and gravitational ones), excited by the corresponding dipole radiation in a course of their $[C \rightleftharpoons W]$ pulsations.

In accordance to known Helmholtz theorem: $\mathbf{F} = \mathbf{rot} \mathbf{A} + \mathbf{grad} \varphi$, each kind of vector field (\mathbf{F}), tending to zero on the infinity, can be presented, as a sum of *rotor* of some vector function, determined in our model by spin equilibrium of Bivacuum fermions and antifermions ($\text{BVF}^\uparrow \bowtie \text{BVF}^\downarrow$), named: $\mathbf{A} \equiv \mathbf{S}$ with its divergence, equal to zero and a gradient of some scalar function, which can be a sum of two or more scalar functions, like ($\varphi = \varphi_E + \varphi_G$):

$$\mathbf{F} = \mathbf{rot} \mathbf{S} + \mathbf{grad} (\varphi_E + \varphi_G); \quad \mathbf{div} \mathbf{S} = \mathbf{0} \quad 5.30d$$

where: φ_E and φ_G are the scalar potentials of electromagnetic and gravitational fields, as a components of field (\mathbf{F}) and \mathbf{S} is a vector potential of this field.

Potentials φ_E and φ_G are representing virtual spherical waves. It is known, that general solution of the wave equation for any spherical wave is:

$$\varphi_{E,G} = \frac{1}{r} f_1(ct - r) + \frac{1}{r} f_2(ct + r) \quad 5.30e$$

where: f_1 and f_2 are arbitrary functions; $\frac{1}{r} f_1(ct - r)$ and $\frac{1}{r} f_2(ct + r)$ are the potentials of diverging wave and converging wave, correspondingly.

The rotational energy contribution, standing for mass of rest (m_0) and charge (e_0) origination, satisfies the Golden mean conditions, due to resonant exchange interaction of each lepton generation ($i = e, \mu, \tau$) with Bivacuum virtual pressure waves (VPW^\pm) of fundamental frequency, corresponding to three leptons generation ($i = e, \mu, \tau$): $[\omega_0 = m_0 c^2 / \hbar]^i$.

The mass and charge symmetry shifts at GM conditions (Kaivarainen, 2002), accessible for experimental detection, are:

$$[\Delta m_C^\phi = |m_C^+ - m_C^-|^\phi = m_0 = \phi(m_C^+)^\phi = (m_C^+ v^2)^\phi / c^2]^i \quad 5.31$$

$$\Delta e^\phi = |e_+ - e_-|^\phi = e_0 = \phi e \sim \Delta m_C^\phi \quad 5.31a$$

where the resulting *internal* charge from 5.22a is equal to: $e = \sqrt{|e_+ e_-|}$ and $e_0/e = \phi$

The difference between e_0 and e can be a consequence of zero-point oscillation and screening of e_+ and e_- by slightly asymmetric and charged Bivacuum fermions (BVF^\uparrow)* under the influence of matter.

In general case the external velocity (v) dependent quantization of mass symmetry shift: $|\Delta m_C| = nm_0$ is directly related to quantization of charge: $|\Delta e| = ne_0 = n\phi e$.

It is important to note, that the ratio of charge and mass symmetry shifts is a permanent value:

$$\frac{|\Delta e|}{|\Delta m_C|} = \frac{\phi e}{m_0} \quad 5.31b$$

5.8 Different presentations of the local energy contributions, related to spin field, electric and gravitational potentials at Golden mean conditions

The rotational - spin contribution in total energy of *sub-elementary particles*, which creates the rest mass and *spin potential*, can be presented for corpuscular $[C]$ and wave $[W]$ phase, as follows (<http://arXiv.org/abs/physics/0207027>):

$$\mathbf{E}_S^n(F_{\uparrow}^{\pm})_{[C]}^i = \left([m_C^+ v_{rot}^2]^{\phi} = [m_C^+]^{\phi} (\phi c)^2_{rot} = \frac{\hbar^2}{[m_C^+ (L_C^+)^2]^{\phi}} \right)_{[C]}^i \quad 5.32$$

$$\mathbf{E}_S^n(F_{\uparrow}^{\pm})_{[W]}^i = \left(|m_C^+ - m_C^-|^{\phi} c^2 = m_0 c^2 = \frac{\hbar^2}{m_0 L_0^2} = m_0 \omega_0^2 L_0^2 = \hbar \omega_0 \right)_{[W]}^i \quad 5.32a$$

where the Golden mean angle frequency is $\omega_0 = m_0 c^2 / \hbar$; the corresponding Compton radius $L_0 = \hbar / m_0 c$ and the energies of both phase are equal: $\mathbf{E}_S^n(F_{\uparrow}^{\pm})_{[C]}^i = \mathbf{E}_S^n(F_{\uparrow}^{\pm})_{[W]}^i$

The energy contribution of longitudinal vibration, induced by $[C \rightleftharpoons W]$ pulsation of uncompensated sub-elementary particles F_{\uparrow}^{\pm} of triplets $\langle [F_{\uparrow}^- \times F_{\uparrow}^+] + F_{\uparrow}^{\pm} \rangle$, is responsible for **electric potential** of elementary particles. At Golden mean conditions it can be presented for $[C]$ and $[W]$ phase as (<http://arXiv.org/abs/physics/0207027>):

$$\mathbf{E}_E^n(F_{\uparrow}^{\pm})_{[C]}^i = \left[\alpha [m_C^+ v_{res}^2]^{\phi} = \alpha \left[\frac{\mathbf{p}^2}{m_C^+} \right]^{\phi} = [m_C^+ v_{\parallel tr}^2]^{\phi} = (zc)^2 [m_C^+]^{\phi} = \alpha \phi [m_C^+]^{\phi} c^2 \right]_{[C]}^i \quad 5.33$$

$$\mathbf{E}_E^n(F_{\uparrow}^{\pm})_{[W]}^i = \left[\left(\frac{e_+ e_-}{L^{\pm}} \right)^{\phi} = \alpha (m_C^+ - m_C^-)^{\phi} c^2 = \alpha m_0 c^2 \right]_{[W]}^i \quad 5.33a$$

where: v_{res} is the resulting rotational-translational velocity of sub-elementary fermion (5.26a); $v_{\parallel tr}^{\phi} = zc$ is a velocity of longitudinal translational *zero-point vibrations*; $z = (\alpha \phi)^{1/2}$ is a longitudinal zero-point factor; $\alpha = e^2 / \hbar c$ is the electromagnetic fine structure constant; $(L^{\pm} = \hbar / [(m_C^+ - m_C^-)^{\phi} c] = L_0)^i$ is a characteristic dimension of asymmetric double cell-dipole separating the actual (e_+) and complementary (e_-) charge of each of three sub-elementary particles of the electron or positron $\langle [F_{\uparrow}^- \times F_{\uparrow}^+] + F_{\uparrow}^{\pm} \rangle^i$.

The energy contribution of transversal vibration of unpaired sub-elementary particle of triplets $\langle [F_{\uparrow}^- \times F_{\uparrow}^+] + F_{\uparrow}^{\pm} \rangle^i$, induced by $[C \rightleftharpoons W]$ pulsation, is responsible for **gravitational potential** of elementary particles. At Golden mean conditions the gravitational potential can be presented as:

$$\mathbf{E}_G^n(F_{\uparrow}^{\pm})_{[C]}^i = \left[\beta [m_C^+ v_{res}^2]^{\phi} = \beta \left[\frac{\mathbf{p}^2}{m_C^+} \right]^{\phi} = [m_C^+ v_{\perp tr}^2]^{\phi} = (xc)^2 [m_C^+]^{\phi} = \beta \phi [m_C^+]^{\phi} c^2 \right]_{[C]}^i \quad 5.34$$

$$\mathbf{E}_G^n(F_{\uparrow}^{\pm})_{[W]}^i = \left[G \left(\frac{m_C^+ m_C^-}{L^{\pm}} \right)^{\phi} = \beta (m_C^+ - m_C^-)^{\phi} c^2 = \beta m_0 c^2 = \Delta m_{\nu}^{\phi} c^2 \right]_{[W]}^i \quad 5.34a$$

where: v_{res} is the resulting rotational-translational velocity of sub-elementary fermion (5.26a); $v_{\perp tr} = xc$ is a velocity of transversal translational *zero-point vibrations*, responsible for gravitation; $x = (\beta \phi)^{1/2}$ is a transversal zero-point factor.

The electromagnetic and gravitational interaction energy between two particles (1) and (2) can be presented as the square root of product of corresponding potentials of particles:

$$\mathbf{E}_E^{1,2} = [\mathbf{E}_E^{(1)} \mathbf{E}_E^{(2)}]^{1/2} \quad 5.42$$

$$\mathbf{E}_G^{1,2} = [\mathbf{E}_G^{(1)} \mathbf{E}_G^{(2)}]^{1/2} \quad 5.42a$$

The spin-spin interaction energy between two elementary particles can be expressed in similar way:

$$\mathbf{E}_S^{1,2} = [\mathbf{E}_S^{(1)} \mathbf{E}_S^{(2)}]^{1/2} \quad 5.42b$$

The longitudinal and transversal velocities of elementary particle and corresponding factors at Golden mean conditions are summarized below:

$$v_{\parallel tr}^{\phi} = zc \quad \text{where :} \quad z = (\alpha\phi)^{1/2} \quad \text{and} \quad \left(\frac{v_{\parallel tr}^{\phi}}{c} \right)^2 = \alpha\phi \quad 5.34b$$

$$v_{\perp tr}^{\phi} = xc \quad \text{where :} \quad x = (\beta\phi)^{1/2} \quad \text{and} \quad \left(\frac{v_{\perp tr}^{\phi}}{c} \right)^2 = \beta\phi \quad 5.34c$$

These minimum values of two kinds of translational velocities correspond to zero-point vibrations of elementary particles, accompanied their $[C \rightleftharpoons W]$ pulsation.

Now, the minimum external resulting group velocity of elementary particle, corresponding to zero-point vibrations at GM conditions, using (5.25b and 5.34b,c), can be presented, like:

$$v_0^2 = c^2\phi + (v_{\parallel tr}^{\phi})^2 + (v_{\perp tr}^{\phi})^2 = c^2\phi + c^2\alpha\phi + c^2\beta\phi = c^2(\phi + \alpha\phi + \beta\phi) \quad 5.34d$$

5.9 Interrelation between the spin field, electromagnetic and gravitational fields energies and their space curvatures at Golden mean conditions

The energy of *spin field*, of each generation of elementary particles ($i = e, \mu, \tau$) is independent on their translational energy and always determined by Golden mean conditions:

$$\left[E_S = E_{rot} = |m_C^+ - m_C^-| \phi c^2 = m_0 c^2 = m_0 \omega_0^2 L_0^2 = \frac{\hbar^2}{m_0 L_0^2} \right]^i \quad 5.35$$

The *curvature*, corresponding to spin field, generated by sub-elementary particle, is equal to its Compton radius:

$$\left[L_S = \frac{\hbar}{|m_C^+ - m_C^-| \phi c} = \frac{\hbar}{m_0 c} \equiv L_0 \right]^i \quad 5.36$$

As it was mentioned in section 5.4, the energy of spin field of unpaired sub-elementary particle is local and reversible in the process of $[C \rightleftharpoons W]$ pulsation in contrast to nonlocal action of the angular momentum of CVC on $[BVF^{\uparrow} \rightleftharpoons BVF^{\downarrow}]$ dynamic equilibrium.

The *curvature of Bivacuum*, corresponding to symmetry shift, related to *longitudinal* zero-point vibrations of elementary particles, can be find from the electric potential:

$$E_E = \alpha |m_C^+ - m_C^-| \phi c^2 = \alpha m_0 c^2 = \alpha \frac{\hbar c}{L_0} \quad 5.37$$

The corresponding to electric potential space curvature at Golden mean conditions $|m_C^+ - m_C^-| \phi = m_0$, is equal to radius of $E - domains$ nonlocality $(L_{BVF}^i)_E$:

$$L_E^{\phi} = \frac{1}{\alpha} \frac{\hbar}{m_0 c} = \frac{1}{\alpha} L_0 = \frac{\hbar}{m_C^+ v_{\parallel tr}} = (L_{BVF}^i)_E \quad 5.38$$

From (5.37) we can see, that the curvature radius, corresponding to electric potential of particle exceeds its Compton radius, equal to spin field curvature (L_S) , to about 137 times:

$$\frac{L_E^{\phi}}{L_S} = \frac{L_E^{\phi}}{L_0} = \frac{1}{\alpha} \sim 137 \quad 5.39$$

In similar way, the curvature of Bivacuum, related to *transversal* zero-point vibrations of elementary particles, is defined by the value of gravitational potential at GM conditions:

$$E_G = \beta |m_C^+ - m_C^-| c^2 = \beta \frac{\hbar c}{L_0}$$

The corresponding gravitational curvature, equal to radius of gravitational domains of

nonlocality is:

$$L_G^\phi = \frac{1}{\beta} \frac{\hbar}{m_0 c} \quad 5.40$$

The gravitational curvature radius of Bivacuum symmetry compensation exceeds the Compton radius of the electron to 10^{45} times:

$$\frac{L_G^\phi}{L_0} = \frac{1}{\beta} = \left(\frac{M_{Pl}}{m_0} \right)^2 \sim 10^{45} \quad 5.41$$

$$or : L_G^\phi \sim 10^{45} L_0 \quad 5.42$$

5.10 Curvature of Bivacuum domains of nonlocality

It follows from our theory, that nonlocal shift of symmetry between properties of rotors (V^+) and antirotors (V^-), forming $BVF^\dagger \sim [V^+ + V^-]$ of Bivacuum, as a compensation of local symmetry shifts, induced by *translational vibrations (longitudinal and transversal)*, is accompanied by emergency of difference between the actual and complementary mass: $|m_C^+ - m_C^-| > 0$ and the actual and complementary charge: $|e_+ - e_-| > 0$. This shift in Bivacuum dipoles (BVF^\dagger) in the 'empty' space is much less, than the mass and charge shifts in sub-elementary particles $F_\dagger^\pm > 0$. However, in accordance to formula (5.20), even small decreasing of ratio $|m_C^-/m_C^+|_{BVF^\dagger} < 1$ means that the *external translational* velocity of BVF^\dagger becomes more, than zero ($v_{ext} \equiv v = c \left[1 - \left| \frac{m_C^-}{m_C^+} \right|_{BVF^\dagger} \right]^{1/2} > 0$), as well as their momentum ($p_{BVF}^i = m_{BVF}^i v_{ext}$) > 0 . Correspondingly, the external virtual wave B length of BVF^\dagger becomes less, than infinity:

$$L_{BVF}^i = \frac{\hbar}{m_{BVF}^i v_{ext}} = \frac{\hbar}{m_{BVF}^i c \left[1 - \left| \frac{m_C^-}{m_C^+} \right|_{BVF^\dagger} \right]^{1/2}} < \infty \quad 5.42a$$

In turn, this means that the condition of infinitive virtual Bose condensation (**VirBC**), pertinent for primordial Bivacuum, is violated (see Kaivarainen, <http://arXiv.org/abs/physics/0207027>)¹⁷ and nonlocality remains possible only in domains of secondary Bivacuum with radius, with dimensions determined by (5.41a). The artificial variation of L_{BVF}^i means Bivacuum engineering due to change the 'interfacial' effects between domains of virtual Bose condensation (**VirBC**), equal to that of nonlocality.

VirBC is *virtual Bose condensation* of Cooper - like pairs [$BVF^\dagger \bowtie BVF^\dagger$] and [BVB^\pm], providing the nonlocal properties of Bivacuum domains. These domains represent multilayer structure. Each of 2D layer is formed by pairs [$BVF^\dagger \bowtie BVF^\dagger$] with defects, represented by [BVB^\pm].

5.11 Neutrino and Antineutrino in Unified Model

We put forward a conjecture, that neutrino or antineutrino of three lepton generation, represents a stable non-local Bivacuum symmetry excitations, compensating the local symmetry oscillations, accompanied the creation of the electron's or positron's and their transversal (\perp) translational vibrations. These kind of vibrations are activated by the in-phase [$C \rightleftharpoons W$] pulsation of pairs [$F_\dagger^- \bowtie F_\dagger^+$]ⁱ of triplets $< [F_\dagger^- \bowtie F_\dagger^+] + F_\dagger^\pm >^i$, responsible for *gravitational potential of elementary particles*.

The quantized energy of neutrinos and antineutrinos is related to the rest mass of corresponding generations of the electron and positron ($\pm m_0^{e,\mu,\tau}$) in following manner (see 5.34):

$$E_{e,\mu,\tau}^{v,\tilde{v}} = [m_C^+ v_{\perp tr}^2]_{e,\mu,\tau}^{v,\tilde{v}} = \pm \beta_{e,\mu,\tau} (m_0^{e,\mu,\tau}) c^2 \left(\frac{1}{2} + n \right) = \pm \Delta (m_V^{e,\mu,\tau}) c^2 \left(\frac{1}{2} + n \right) \quad 5.43$$

where ($\pm m_0^{e,\mu,\tau}$) are the rest mass of [e, μ, τ] generations of electrons and positrons;

$\beta_{e,\mu,\tau} = (m_0^{e,\mu,\tau}/M_{Pl})^2$ is a gravitational fine structure constants, introduced in our theory of gravitation (<http://arXiv.org/abs/physics/0207027>); $\pm\Delta(m_{\bar{\nu}}^{e,\mu,\tau})c^2 = \pm\beta_{e,\mu,\tau}(m_0^{e,\mu,\tau})c^2$ are the amplitude of Bivacuum symmetry vibrations, corresponding to three neutrino flavors $[e, \mu, \tau]$ at Golden mean conditions.

The charge of neutrino/antineutrino ($\pm e_\nu$), proportional to symmetry shift:
 $\pm\Delta(m_{\bar{\nu}}^{e,\mu,\tau}) = \pm\beta_{e,\mu,\tau}(m_0^{e,\mu,\tau})$ (see for comparison 5.31a) is very close to zero:

$$\pm e_\nu = \pm\beta_{e,\mu,\tau}e_0 \cong 0 \quad 5.43a$$

The evidence of neutrino flavor oscillation: $e \rightleftharpoons \mu \rightleftharpoons \tau$ has been recently obtained in Sudbury Neutrino Observatory (SNO, 2002). This means possibility of collective quantum transitions between symmetry shifts of secondary Bivacuum: $\Delta(m_{\bar{\nu}}^e) \rightleftharpoons \Delta(m_{\bar{\nu}}^\mu) \rightleftharpoons \Delta(m_{\bar{\nu}}^\tau)$, as a result of interconversions between three basic generation of cell-dipoles $(BVF^\pm)^i$ with three corresponding resulting mass: $(m_0^e) \rightleftharpoons (m_0^\mu) \rightleftharpoons (m_0^\tau)$, where $m_0^i = \sqrt{(m_C^+ m_C^-)^i}$.

It is known, that neutrinos ($\nu_e; \nu_\mu; \nu_\tau$) always originates in pairs with antielectrons ($e^+; \mu^+; \tau^+$) and antineutrinos ($\bar{\nu}_e; \bar{\nu}_\mu; \bar{\nu}_\tau$) in pairs with leptons ($e^-; \mu^-; \tau^-$).

Neutrino and antineutrino may be considered, as collective excitations of huge domains of Bivacuum in state of virtual Bose condensation (VirBC). The characteristic radius of such excited state, characterizing the neutrino curvature is equal to:

$$L_{\nu_{e,\mu,\tau}}^{(n)} = \frac{\hbar}{c[\beta m_0]_{e,\mu,\tau}(\frac{1}{2} + n)} \quad 5.43b$$

Obviously, the neutrino/antineutrino directly participate in gravitational (G) interaction. The energy of G interaction should be dependent on density energy of neutrino and its generation.

5.12 Harmonization energy (HaE) and force (HaF) of Bivacuum, as a background of Time & Principle of Least Action

It is shown, that Principle of least action is a consequence of introduced in our Unified Model (UM) "Harmonization energy (HaE)" of secondary Bivacuum, driving the matter to Golden Mean conditions and responsible for its evolution on all hierarchic levels¹⁷ (Kaivarainen, 2002). We introduce the Harmonization energy $(HaE)^i$ of Bivacuum, acting on three generations ($i = e, \mu, \tau$) of elementary particles of matter, as a difference between their total energy of particle ($E_{C \rightleftharpoons W}^i = \hbar\omega_0^i + E_E^i + E_G^i$) and the basic energy of virtual pressure waves of Bivacuum $(VPW^\pm)^i$, equal to the energy of the rest mass of particle: $E_{VPW^\pm}^i = \hbar\omega_0^i = m_0^i c^2$, as postulated in UM:

$$HaE^i = |E_{C \rightleftharpoons W} - E_{VPW^\pm}^i|^i = |m_C^+(v_{gr}^{ext})^2 - m_0 c^2|^i = \hbar|\omega_{C \rightleftharpoons W} - \omega_0|^i = \hbar|\omega_{HaE}|^i = p_{HaE}^i c \quad 5.44$$

where the frequency of Harmonization energy $|\omega_{HaE}|^i$ is equal to frequency of quantum beats between frequency of $[C \rightleftharpoons W]$ pulsation of elementary particles ($\omega_{C \rightleftharpoons W}$) and fundamental frequency (ω_0) of Bivacuum virtual pressure waves $(VPW^\pm)^i$:

$$|\omega_{HaE}|^i = |\omega_{C \rightleftharpoons W} - \omega_0|^i = p_{HaE}^i c / \hbar \quad 5.44a$$

The momentum of HaE^i can be expressed, as

$$p_{HaE}^i = \hbar \frac{|\omega_{HaE}|^i}{c} = \frac{\hbar}{L_{HaE}^i} \quad 5.44b$$

The virtual Harmonization wavelength, as a carrier of Harmonization energy is:

$$\lambda_{HaE}^i = 2\pi L_{HaE}^i = 2\pi c / |\omega_{HaE}|^i$$

Taking into account the expressions for total energy of elementary particle (5.24-5.24c), the eq.(5.44) for Harmonization energy can be expressed via the sum of Electromagnetic and Gravitational potentials $(E_E + E_G)^i$. These potentials are related directly to longitudinal $|m_C^+ v_{||tr}^2|^i = E_E^i$ and transversal $|m_C^+ v_{\perp tr}^2|^i = E_G^i$ translational contributions to the total energy

$$(E_{C \rightleftharpoons W}^i = \hbar\omega_0^i + E_E^i + E_G^i):$$

$$HaE^i = (E_{C,W})_{\parallel tr} + (E_{C,W})_{\perp tr}^i = (E_E + E_G)^i = \hbar|\omega_{C \rightleftharpoons W} - \omega_0|^i = p_{HaE} c \quad 5.45a$$

$$= |m_C^+ - m_C^-|_{\parallel tr} c^2 + |m_C^+ - m_C^-|_{\perp tr} c^2 = |m_C^+ v_{\parallel tr}^2|^i + |m_C^+ v_{\perp tr}^2|^i = \quad 5.45b$$

$$= m_0^i c^2 \frac{(v_{\parallel}/c)^2}{[1 - (v/c)^2]^{1/2}} + m_0^i c^2 \frac{(v_{\perp}/c)^2}{[1 - (v/c)^2]^{1/2}} = HaF^i \lambda_{HaE}^i \quad 5.45c$$

where the resulting group velocity from (5.24), is:

$$\mathbf{v}^2 = (\mathbf{v}_{rot}^2)^\phi + \mathbf{v}_{\parallel tr}^2 + \mathbf{v}_{\perp tr}^2 = \mathbf{c}^2 \phi + \mathbf{v}_{\parallel tr}^2 + \mathbf{v}_{\perp tr}^2 \quad 5.45d$$

$HaF^i = HaE^i/\lambda_{HaE}^i$ is the Harmonization force of Bivacuum.

The induced resonant influence of Bivacuum fundamental frequency: $\omega_0^i = m_0^i c^2/\hbar$ of virtual pressure waves (VPW $^\pm$) of Bivacuum, corresponding to Harmonization Energy on frequency of $[C \rightleftharpoons W]$ pulsation and other kind of dynamics of elementary particles, atoms and molecules - could be a physical background of *Principle of Least Action*, as demonstrated below.

The *Action* in Lagrangian form for any elementary particle, taking into account (5.44 and 5.45a) can be presented as:

$$[S = S^{ext} - S^{in} = \hbar|\omega_{HaE}|t = |m_C^+(v_{gr}^{ext})^2 - m_0 c^2|t = (E_E + E_G)t = (HaE)t]^i \quad 5.46$$

The Principle of least action, demanding that variation of action should be minimum ($\delta S = 0$), leads to important result:

$$\delta S = [\delta(HaE^i)t + E_{HaE}^i \delta t]^i = 0 \quad 5.47$$

or, using (5.45a,b), we come to formulation of notion of dimensionless *pace of time*:

$$\left[\frac{\delta t}{t} \right]^i = -\frac{\delta(HaE^i)}{HaE^i} = -\frac{\delta\omega_{HaE}^i}{\omega_{HaE}^i} = -\frac{\delta[(T_k)_{\parallel tr} + (T_k)_{\perp tr}]^i}{[(T_k)_{\parallel tr} + (T_k)_{\perp tr}]^i} = -\frac{\delta(E_E + E_G)^i}{(E_E + E_G)^i} \quad 5.48$$

This formula interrelates the pace of time $[\frac{\delta t}{t}]^i = d \ln t^i$ *for free particles* of three generations ($i = e, \mu, \tau$) with pace of changes of kinetic energy contributions, responsible for electromagnetic and gravitational potentials of these particles.

In general logarithmic form the formula for unification of time, harmonization energy of Bivacuum, electromagnetic and gravitational fields (5.48) turns to:

$$\begin{aligned} \mathbf{d} \ln \mathbf{t}^i &= -\mathbf{d} \ln \mathbf{HaE}^i = -\mathbf{d} \ln \omega_{HaE}^i = -\mathbf{d} \ln (E_E + E_G)^i = \\ &= -\mathbf{d} \ln [(T_k)_{\parallel tr} + (T_k)_{\perp tr}]^i = -\mathbf{d} \ln [\alpha m_C^+ \mathbf{v}^2 + \beta m_C^+ \mathbf{v}^2]^i \end{aligned} \quad 5.48a$$

For the closed system of N interacting coherent particles (i.e. in state of mesoscopic Bose condensation) at the permanent for this system time period ($t = T = 1/\nu = const$), when $\delta t = \delta T = 0$, the **Principle of least action**, leading from (5.47 and 5.45a,b), can be presented as:

$$\sum_k^N (\delta HaE^i)_k T = \frac{1}{\nu} \sum_k^N \delta (HaE_k^i) = 0 \quad \text{at :} \quad t = T = 1/\nu = const > 0 \quad 5.49$$

$$\text{or :} \quad \sum_k^N \delta (HaE_k^i) = \sum_k^N \delta [E_E + E_G]^i = \sum_k^N \delta [|m_C^+ v_{\parallel tr}^2|^i + |m_C^+ v_{\perp tr}^2|^i] = 0 \quad 5.49a$$

This means that at the permanent Harmonization energy of Bivacuum:

$E_{HaE}^i = \hbar|\omega_{HaE}^i| = const$, the variations of the electric and gravitational potentials should compensate each other, as well, as corresponding longitudinal and transversal translational contributions to resulting kinetic energy of elementary particles:

$$\sum_k^N \delta E_E^i = \sum_k^N -\delta E_G^i \quad 5.49b$$

$$\text{or: } \sum_k^N \delta |m_C^+ v_{\parallel tr}^2|^i = \sum_k^N -\delta |m_C^+ v_{\perp tr}^2|^i$$

Such kind of electromagnetism - gravitation compensation phenomena, based on Least action, also may contribute to Bivacuum mediated interaction between Sender [S] and Receiver [R].

Except *Harmonization energy of Bivacuum* (HaE - 5.45a), we may introduce also the *Harmonization force of Bivacuum* (HaF), acting on internal and external dynamics of elementary particles and atoms, like time derivative of Harmonization energy momentum ($F_{HaF}^i = \partial p_{HaE}^i / \partial t$), where from (5.44b) the momentum: $p_{HaE}^i = E_{HaE}^i / c = \hbar|\omega_{HaE}^i| / c = \hbar/L_{HaE}^i$

The *Harmonization force* of Bivacuum can expressed as:

$$HaF^i = \partial p_{HaE}^i / \partial t = \frac{\partial}{\partial t} [|m_C^+ - m_C^-|_{\parallel tr} c + |m_C^+ - m_C^-|_{\perp tr}]^i c = \quad 5.50$$

$$= \frac{\partial}{\partial t} [\alpha/c |m_C^+ v^2|^i + \beta/c |m_C^+ v^2|^i] = \frac{\partial}{\partial t} [E_{el}^i + E_G^i] \quad 5.51$$

This expression means, that HaF of Bivacuum, acting on matter, is a result of Bivacuum *feedback reaction*, determined by temporal change of electromagnetic and gravitational fields, radiated by matter.

The another possible way of HaF presentation, leads from HaE definition (5.45c): $HaE^i = \hbar v_{HaE}^i = [E_E + E_G]^i = HaF^i \lambda_{HaE}^i$ and from (5.45a):

$$HaF^i = \frac{\hbar (v_{HaE}^i)^2}{c} = \left(\frac{\hbar v_{HaE}^i}{\lambda_{HaE}^i} \right)^i = \frac{(\omega_{C \rightleftharpoons W} - \omega_0)^i}{2\pi c} [E_E^i + E_G^i] \quad 5.51a$$

$$\text{or: } HaF^i = \left(\frac{[E_E^i + E_G^i]^2}{hc} \right)^i = \left(\frac{[\alpha m_C^+ v^2 + \beta m_C^+ v^2]^2}{hc} \right)^i$$

where:

$$\lambda_{HaE}^i = 2\pi c / (\omega_{C \rightleftharpoons W} - \omega_0) = hc / [E_E + E_G]^i \quad 5.51b$$

is the wave length of HaE field; $(\omega_{C \rightleftharpoons W} - \omega_0) = \omega_{HaE}$ is a frequency of Harmonization energy of Bivacuum, acting on dynamics of pulsing elementary particles.

We get the important conclusion, based on (5.51a), that the bigger is electromagnetic and gravitational radiation of particle/matter, proportional to particles kinetic energy, the bigger is Harmonization force of Bivacuum, acting on this particles. This means that HaF tends to slow down the external dynamics of particles, increasing the probability of coherent Bose condensation of matter and shifting the properties of matter closer to those of Golden mean.

6 Possible mechanism of entalgement in microscopic and macroscopic systems

6.1 Quantum entanglement between coherent elementary particles

For explanation of nonlocal quantum entanglement between two or more particles we put forward the hypothesis, that *Virtual spin waves (VirSW)*, excited by the angular moments of cumulative virtual clouds (CVC) of sub-elementary particles in triplets $\langle [F_{\uparrow}^- \times F_{\downarrow}^+] + F_{\uparrow}^{\pm} \rangle$, are highly anisotropic, depending on orientation (polarization) of triplets in space, and able to form **nonlocal virtual wave-guides (VirWG)** with internal magnetic field and refraction index much higher than the external ones ($\mathbf{H}_{in} \gg \mathbf{H}_{ext}$; $n_{in} > n_{ext}$).

The experimental data are existing, indeed, pointing to change of vacuum refraction index in strong magnetic fields (Ginsburg, 1987).

The Virtual spin waves, excited by $[C \rightleftharpoons W]$ pulsation of unpaired sub-elementary particle F_{\uparrow}^{\pm} form:

$$(VirSW)_{F_{\uparrow}^{\pm}} \sim (VirWG)_{F_{\uparrow}^{\pm}} \equiv (VirWG)$$

The Virtual spin waves, excited by $[C \rightleftharpoons W]$ pulsation of pair $[F_{\uparrow}^- \times F_{\downarrow}^+]$, can form a pair of $[VirWG^{\cup} \times VirWG^{\cup}]_{F_{\uparrow}^- \times F_{\downarrow}^+}$, which participate in Virtual Replica of matter formation. However, the energy of virtual photons and phase of $[C \rightleftharpoons W]$ pulsation, channelled by this pair, almost totally compensate each other.

The uncompensated *VirWG* is most effective as a phase conductor/modulator between elementary particles of the same frequency of $[C \rightleftharpoons W]$ pulsation.

We propose also, that the virtual photons, as a part of CVC energy, can propagate via VirWG. The Faraday cage can't shield such kind of EM field directed tunnelling via Bivacuum virtual wave-guide.

The mechanism of $(VirWG)_{F_{\uparrow}^{\pm}}$ and $[VirWG^{\cup} \times VirWG^{\cup}]_{F_{\uparrow}^- \times F_{\downarrow}^+}$ formation between Sender [S] and Receiver [R], representing two or more (N) coherent elementary particles, is determined by realization of principle of least action for such system in form of (5.49a):

$$\sum_k^N \delta(HaE_k^i) = \sum_k^N \delta[E_E + E_G]^i = \sum_k^N \delta[|m_C^+ v_{\parallel tr}^2|^i + |m_C^+ v_{\perp tr}^2|^i] = 0 \quad 6.1$$

where: HaE_k^i is Harmonization energy of Bivacuum; $E_E = |m_C^+ v_{\parallel tr}^2|^i$ and $E_G = |m_C^+ v_{\perp tr}^2|^i$ are electromagnetic and gravitational potentials of elementary particles.

The *nonlocal* interaction via *VirWG* - channel between two coherent elementary particles may change a phase of 2nd particle after changing the phase of the 1st one, but not the energy, related to irreversible electromagnetic and gravitational contributions to energy of $[C \rightleftharpoons W]$ pulsation of elementary particles ($E_{C \rightleftharpoons W} = m_C^+ c^2 = \hbar \omega_{C \rightleftharpoons W}$). *The VirSW themselves are the carriers of the angle momentum or spin, i.e. phase of CVC only.*

Let us consider the energetic processes, accompanied $[C \rightleftharpoons W]$ pulsation of unpaired (F_{\uparrow}^{\pm}) and quasisymmetric pair $[F_{\uparrow}^- \times F_{\downarrow}^+]$ of any selected triplet (electron or positron), related with [emission \rightleftharpoons absorption] of Cumulative Virtual Clouds (CVC $^{\pm}$) of sub-quantum particles:

$$\langle [F_{\uparrow}^- \times F_{\downarrow}^+]_C + (F_{\uparrow}^{\pm})_W \rangle \xrightleftharpoons[-E_{CVC^{\pm}}]{+E_{CVC^{\pm}}} \langle [F_{\uparrow}^- \times F_{\downarrow}^+]_W + (F_{\uparrow}^{\pm})_C \rangle \quad 6.1a$$

For unpaired sub-elementary particle of any generation ($i = e, \mu, \tau$):

$$(F_{\uparrow}^{\pm})_W \xrightleftharpoons[-E_{CVC^{\pm}}]{+E_{CVC^{\pm}}} (F_{\uparrow}^{\pm})_C \quad 6.2$$

The corresponding cumulative virtual cloud energy ($E_{CVC^{\pm}}$):

$$\begin{aligned} E_{CVC^{\pm}} = E_W = E_C = E_0 + E_E + E_G &= (m_C^+ v_{rot}^2)^{\phi} + m_C^+ v_{\parallel tr}^2 + m_C^+ v_{\perp tr}^2 = \\ &= m_0 \omega_0^2 L_0^2 + \alpha m_C^+ v^2 + \beta m_C^+ v^2 = m_C^+ v^2 \end{aligned} \quad 6.2a$$

where the rest mass energy, corresponding to Golden mean conditions (Kaivarainen, 2002) is

$$E_0 = (m_C^+ \mathbf{v}_{rot}^2)^\phi = m_0 c^2 = m_0 \omega_0^2 L_0^2$$

and the resulting external group velocity is (5.45d):

$$\mathbf{v}^2 = (\mathbf{v}_{rot}^2)^\phi + \mathbf{v}_{\parallel tr}^2 + \mathbf{v}_{\perp tr}^2 = \mathbf{c}^2 \phi + \mathbf{v}_{\parallel tr}^2 + \mathbf{v}_{\perp tr}^2$$

At the Golden mean (ϕ) conditions the resulting zero-point velocity is permanent and can be expressed as:

$$\mathbf{v}_0^2 = \mathbf{c}^2 \phi + (\mathbf{v}_{\parallel tr}^\phi)^2 + (\mathbf{v}_{\perp tr}^\phi)^2 = \mathbf{c}^2 \phi + \mathbf{c}^2 \alpha \phi + \mathbf{c}^2 \beta \phi = \mathbf{c}^2 (\phi + \alpha \phi + \beta \phi)$$

Only the part of energy of CVC^\pm (6.2a), determined by the rest mass of sub-elementary particle $E_0 = m_0 c^2 = E_S$, determined by its rotations/spinning is totally reversible in the process of $[C \rightleftharpoons W]$ pulsation of sub-elementary particles.

The contributions to CVC^\pm energy, related to electromagnetism and gravitation, are radiated irreversibly and lead to certain Bivacuum fermions dynamics perturbations, like small symmetry shifts between properties of rotors (\mathbf{V}^+) and antirotors (\mathbf{V}^-) of Bivacuum fermions, resulting from their nonzero external momentum (see eqs. 6.13 and 6.13a).

For $[C \rightleftharpoons W]$ pulsation of pair $[\mathbf{F}_\uparrow^- \bowtie \mathbf{F}_\downarrow^+]$ we have:

$$[\mathbf{F}_\uparrow^- \bowtie \mathbf{F}_\downarrow^+]_C \xrightarrow{\frac{[E_{CVC^+} + E_{CVC^-}]}{-[E_{CVC^+} + E_{CVC^-}]}} [\mathbf{F}_\uparrow^- \bowtie \mathbf{F}_\downarrow^+]_W \quad 6.3$$

It is important to outline *three important consequences*, following from such consideration:

1. The *experimentally* registrable **energy** of $[C \rightleftharpoons W]$ pulsation of elementary triplet (6.1a), equal to that of unpaired sub-elementary particle (\mathbf{F}_\uparrow^\pm), is limited only by electromagnetic and gravitational contributions:

$$E_{\mathbf{F}_\uparrow^\pm}^{C \rightleftharpoons W} = E_E + E_G = m_C^+ \mathbf{v}_{\parallel tr}^2 + m_C^+ \mathbf{v}_{\perp tr}^2 = \alpha m_C^+ \mathbf{v}^2 + \beta m_C^+ \mathbf{v}^2 \quad 6.3a$$

The energy of virtual spin waves, averaged during period of $[C \rightleftharpoons W]$ pulsation is zero:

$$E_{VirSW} = (m_0 \omega_0^2 L_0^2)_{C \rightarrow W} - (m_0 \omega_0^2 L_0^2)_{W \rightarrow C} = 0$$

due to the total reversibility of rotational contribution to CVC energy. Consequently, the nonlocal VirWG, formed by VirSW, is a carrier of the phase only. Possibly, in some cases, it may serve, as a *channel* conducting virtual photons, related with electromagnetic contribution of unpaired sub-elementary particle: $E_E = m_C^+ \mathbf{v}_{\parallel tr}^2 = \alpha m_C^+ \mathbf{v}^2$. In such a case the EM radiation of the electron should be highly anisotropic;

2. To keep a structure of triplet of sub-elementary particles stable and energetically symmetric, the changes of the energy of unpaired (\mathbf{F}_\uparrow^\pm), should be accompanied by similar changes in the absolute energy of each of other sub-elementary particle and antiparticle in pair $[\mathbf{F}_\uparrow^- \bowtie \mathbf{F}_\downarrow^+]$:

$$\left| -\Delta E_{\mathbf{F}_\uparrow^- \bowtie \mathbf{F}_\downarrow^+}^{\mathbf{F}_\uparrow^\pm} \right| = \left| \Delta E_{\mathbf{F}_\uparrow^- \bowtie \mathbf{F}_\downarrow^+}^{\mathbf{F}_\uparrow^\pm} \right| = \Delta E_{\mathbf{F}_\uparrow^\pm} = [\Delta(m_C^+ \mathbf{v}_{\parallel tr}^2) + \Delta(m_C^+ \mathbf{v}_{\perp tr}^2)]_{\mathbf{F}_\uparrow^\pm} = [\Delta E_E + \Delta E_G]_{\mathbf{F}_\uparrow^\pm} \quad 6.3b$$

The energy increments of sub-elementary particle and sub-elementary antiparticles in pairs $[\mathbf{F}_\uparrow^- \bowtie \mathbf{F}_\downarrow^+]$ are equal (or almost equal) and opposite by sign to each other. Consequently, their sum is always zero and these increments do not contribute to resulting energy of triplets, determined by unpaired sub-elementary particle:

$$\Delta E_{\mathbf{F}_\uparrow^- \bowtie \mathbf{F}_\downarrow^+}^{\mathbf{F}_\uparrow^\pm} + \left(-\Delta E_{\mathbf{F}_\uparrow^- \bowtie \mathbf{F}_\downarrow^+}^{\mathbf{F}_\uparrow^\pm} \right) \cong 0 \quad 6.3c$$

3. *Virtual Replica (VR) of matter formation*. The opposite energy variations

$$\begin{aligned}\Delta E_{\mathbf{F}_\uparrow^- \bowtie \mathbf{F}_\uparrow^+}^{\mathbf{F}_\uparrow^+} &= \Delta(m_0 \omega_0^2 L_0^2 + am_C^+ \mathbf{v}^2 + \beta m_C^+ \mathbf{v}^2) \\ - \Delta E_{\mathbf{F}_\uparrow^- \bowtie \mathbf{F}_\uparrow^+}^{\mathbf{F}_\uparrow^-} &= -\Delta(m_0 \omega_0^2 L_0^2 + am_C^+ \mathbf{v}^2 + \beta m_C^+ \mathbf{v}^2)\end{aligned}\quad 6.3d$$

in pairs $[\mathbf{F}_\uparrow^- \bowtie \mathbf{F}_\uparrow^+]$ stand for interaction between elementary particles and energy realms of Bivacuum (positive and negative) in a course of $[C \rightleftharpoons W]$ pulsation of elementary triplets (see 6.1a). This interaction is near the resonant one, because the fundamental frequency of Bivacuum, corresponding to that of Golden mean: $\omega_0 = m_0 c^2 / \hbar$ (Kaivarainen, 2002), is close to frequency of $[C \rightleftharpoons W]$ pulsation of sub-elementary particles/antiparticles in nonrelativistic conditions ($\mathbf{v} \ll \mathbf{c}$), i.e. when:

$$\omega_{C \rightleftharpoons W}^{\langle [\mathbf{F}_\uparrow^- \bowtie \mathbf{F}_\uparrow^+] + \mathbf{F}_\uparrow^\pm \rangle} = \frac{1}{\hbar} (m_0 c^2 + am_C^+ \mathbf{v}^2 + \beta m_C^+ \mathbf{v}^2) \simeq m_0 c^2 / \hbar = m_0 \omega_0^2 L_0^2 / \hbar \quad 6.3e$$

For the other hand, perturbation of positive and negative parts of Bivacuum dipoles ($BVF^\uparrow = \mathbf{V}^+ \uparrow \mathbf{V}^-$) see (5.1-5.3) by electromagnetic and gravitational contributions (6.3b) of the energy of each of sub-elementary particles of the pairs $[\mathbf{F}_\uparrow^- \bowtie \mathbf{F}_\uparrow^+]$:

$$E_{\mathbf{F}_\uparrow^- \bowtie \mathbf{F}_\uparrow^+}^{\mathbf{F}_\uparrow^+} = -E_{\mathbf{F}_\uparrow^- \bowtie \mathbf{F}_\uparrow^+}^{\mathbf{F}_\uparrow^-} = m_0 \omega_0^2 L_0^2 + am_C^+ \mathbf{v}^2 + \beta m_C^+ \mathbf{v}^2 = m_0 c^2 + [E_E + E_G] = m_C^+ \mathbf{v}^2 \quad 6.3f$$

is responsible for creation of **Virtual Replicas (VR)** of elementary, particles, atoms, molecules, condensed matter and its different forms, including living organisms. The non energetic - phase/informational contribution to VR is provided by Virtual spin waves ($VirSW$) $_{\mathbf{F}_\uparrow^- \bowtie \mathbf{F}_\uparrow^+}$, excited by pairs $[\mathbf{F}_\uparrow^- \bowtie \mathbf{F}_\uparrow^+]$ and double virtual wave guides: $[VirWG^\cup \bowtie VirWG^\cup]_{\mathbf{F}_\uparrow^- \bowtie \mathbf{F}_\uparrow^+}$, formed by $[VirSW^\cup \bowtie VirSW^\cup]_{\mathbf{F}_\uparrow^- \bowtie \mathbf{F}_\uparrow^+}$.

The nonlocal long-range correlation between **two** elementary particles: Sender [S] and Receiver [R] via Bivacuum are provided by massless and nonlocal Virtual spin waves ($VirSW$), activated by cumulative virtual clouds CVC_S^\cup and CVC_R^\cup with opposite *angular momentums/spins* ($S = \pm \frac{1}{2} \hbar$). These clouds are emitted by **uncompensated** sub-elementary particles of two triplets $\langle [F_\uparrow^- \bowtie F_\uparrow^+] + F_\uparrow^\pm \rangle$ with *opposite spins*, as a result of $C \rightarrow W$ transition:

$$[\mathbf{F}_\uparrow^\pm]_S^{C \rightarrow W} \xrightarrow{BvSO_S} CVC_S^\cup \xleftrightarrow[VirSW_S \bowtie VirSW_R]{K_{BVF^\uparrow \rightleftharpoons BVF^\downarrow}} CVC_R^\cup \xleftarrow{BvSO_R} [\mathbf{F}_\uparrow^\pm]_R^{C \rightarrow W} \quad 6.4$$

Two Bivacuum fermions: BVF^\uparrow and BVF^\downarrow with *opposite spins* (6.4) have a properties of virtual Cooper pairs. Spin-spin exchange interaction between them may course the **attraction** in pairs ($BVF^\uparrow \bowtie BVF^\downarrow$) and **"contraction"** of Bivacuum. The virtual *Pauli repulsion* (PR) pressure in Bivacuum, can be a consequence of interaction between distant elementary particles with the **same spins** and in-phase $[C \rightleftharpoons W]$ pulsation of their unpaired sub-elementary particles (6.5). Such effect may induce the Bivacuum **"expanding"**:

$$[\mathbf{F}_\uparrow^\pm]_S^{C \rightarrow W} \xrightarrow{BvSO_S} CVC_S^\cup \xleftrightarrow[VirSW_S \bowtie VirSW_R]{K_{BVF^\uparrow \rightleftharpoons BVF^\downarrow}} CVC_R^\cup \xleftarrow{BvSO_R} [\mathbf{F}_\uparrow^\pm]_R^{C \rightarrow W} \quad 6.5$$

where $BvSO_{S,R}$ means Bivacuum symmetry oscillation, accompanied the emission \rightleftharpoons absorption of cumulative virtual cloud (CVC) of similar angular momentums/spins.

The $[C \rightleftharpoons W]$ pulsation of uncompensated sub-elementary particle \mathbf{F}_\uparrow^\pm and quasisymmetric pair $[\mathbf{F}_\uparrow^- \bowtie \mathbf{F}_\uparrow^+]$ of each triplet of elementary particle $\langle [\mathbf{F}_\uparrow^- \bowtie \mathbf{F}_\uparrow^+] + \mathbf{F}_\uparrow^\pm \rangle$ is accompanied by $VirSW$ excitation with the same frequency:

$$[\omega_{C \rightleftharpoons W} = \omega_{VirSW} = (m_C^+ - m_C^-) c^2 / \hbar] \quad 6.6$$

$L = \hbar / P^{ext}$ is the actual de Broglie wave of particle; $P^{ext} = m_C^+ \omega_C L^+$ is the external momentum of particle.

The anisotropic amplitude probability of resonant exchange interaction between **two** particles: 'sender (S)' and 'receiver (R)' ($A_{C \rightleftharpoons W}$)_{x,y,z} may be qualitatively described, using well known model of **damped harmonic oscillator** interacting with external alternating field:

$$[A_{C \rightleftharpoons W}]_{x,y,z} \sim \left[\frac{1}{(m_C^+)_R} \frac{[HaF]_{x,y,z}}{\omega_R^2 - \omega_S^2 + \text{Im } \gamma \omega_S} \right]_{x,y,z} \quad 6.7$$

where: ω_R and ω_S are the frequencies of $C \rightleftharpoons W$ pulsation of sub-elementary particles of (S) and (R);

γ is a damping coefficient due to exchange interaction of pairs $[\mathbf{F}_\uparrow^- \bowtie \mathbf{F}_\downarrow^+]$ of triplets $\langle [\mathbf{F}_\uparrow^- \bowtie \mathbf{F}_\downarrow^+] + \mathbf{F}_\uparrow^\pm \rangle$ by means of virtual pressure waves (VPW $^\pm$) with flickering noise of Bivacuum.

The local Bivacuum fluctuations nearby [R] or [S] also may be responsible for decoherence and damping of the particles entanglement; $(m_C^+)_R$ is the actual mass of (R).

For the other hand, the influence of Harmonization force of Bivacuum with fundamental Golden mean frequency $\omega_0 = m_0 c^2 / \hbar$ may stimuli synchronization in (S) and (R) pulsations, i.e. $\omega_R \rightarrow \omega_S \rightarrow \omega_0$.

$[HaF]_{x,y,z}$ is a spatially anisotropic *Harmonization force of Bivacuum* (5.51a):

$$HaF^i = \left(\frac{[E_E^i + E_G^i]^2}{hc} \right)^i = \left(\frac{[\alpha m_C^+ v^2 + \beta m_C^+ v^2]^2}{hc} \right) \quad 6.8$$

The effectiveness of nonlocal interaction between two separated elementary particles is dependent on synchronization of $[C \rightleftharpoons W]$ pulsations under the influence of Harmonization force of Bivacuum and VirSW wave-guide channel between Sender and Receiver.

The mechanism, proposed, may explain the theoretical (Einstein, et all. 1935; Cramer, 2001) and experimental evidence in proof of nonlocal interaction between coherent elementary particles (Aspect, et all. 1982; 1983) and atoms.

Our theory predicts, that the same mechanism may provide the distant quantum entanglement between mesoscopic and macroscopic systems, including biological ones, if $[C \rightleftharpoons W]$ pulsations of their particles are 'tuned' to each other and they have close spatial polarization (orientation) and symmetry. (Kaivarainen, 2001d).

6.2. The mechanism of quantum entanglement in macroscopic systems

Let us analyze the possible mechanism of synchronization between macroscopic complex systems in the framework of our Unified model. If we apply the principle of least action in form of (5.49a) to interaction of sender [S] and receiver [R], the N interacting particles of these two subsystems can be subdivided as:

$$N = N_S + N_R \quad 6.9$$

For this case (5.49a) represents a sum of electromagnetic (E_E^i) and gravitational (E_G^i) contributions under the influence of Bivacuum Harmonization energy (HaE, eq. 5.45a):

$$\sum_k^{N_S} \delta \left[\alpha |m_C^+ v^2|^i + \beta |m_C^+ v^2|^i \right] = - \sum_j^{N_R} \delta \left[\alpha |m_C^+ v^2|^i + \beta |m_C^+ v^2|^i \right] \quad 6.10$$

or :

$$\sum_k^{N_S} \delta \left[E_E^i + E_G^i \right] = - \sum_j^{N_R} \delta \left[E_E^i + E_G^i \right] \quad 6.10a$$

This important result, taking into account (5.49), means that variations of kinetic energy of elementary particles of sender N_S should be compensated by the opposite (counterphase) variations of kinetic energy of receiver N_R , responsible for electromagnetism and gravitation after synchronization of their key frequencies by means of nonlocal virtual spin waves (VirSW).

The contribution to VirSW of low frequency ($\nu \sim 10$ Hz) biomagnetic field, generated by correlated nerve excitations (i.e. propagation of electric signals via axons) with wavelength about $\lambda = c/\nu \sim 30\,000$ m or bigger, radiated by [S] and [R], as well as nonlocal Geomagnetic flicker noise in the case of telepathic contact, should be taken into account, as the additional component of Virtual Channel:

$$\sum^n \left[\vec{\mathbf{H}}(\boldsymbol{\mu}_+ - \boldsymbol{\mu}_-)_n \right]_{x,y,z} = \sum^n \left[\vec{\mathbf{H}}(2\boldsymbol{\mu}_B)_n \right]_{x,y,z} \quad 6.11$$

Formulas (6.10 and 6.10a) can be transformed to more general form, reflecting realization of principle of least action for macroscopic system, containing $N = N_S + N_R$ particles:

$$\sum_k^{N_S} \delta \left[\alpha |m_C^+ v^2|^i + \beta |m_C^+ v^2|^i + \vec{\mathbf{H}} 2\boldsymbol{\mu}_B^i \right]_{x,y,z} = - \sum_j^{N_R} \delta \left[\alpha |m_C^+ v^2|^i + \beta |m_C^+ v^2|^i + \vec{\mathbf{H}}(2\boldsymbol{\mu}_B)^i \right]_{x,y,z} \quad 6.12$$

or :

$$\sum_k^{N_S} \delta \left[\mathbf{E}_E^i + \mathbf{E}_G^i + \vec{\mathbf{H}} 2\boldsymbol{\mu}_B^i \right] = - \sum_j^{N_R} \delta \left[\mathbf{E}_E^i + \mathbf{E}_G^i + \vec{\mathbf{H}} 2\boldsymbol{\mu}_B^i \right] \quad 6.12a$$

In secondary Bivacuum the deviation of ratio of mass-energy of the complementary (V^-) and actual (V^+) rotors and antirrotors, forming BVF † from $\left[\frac{m_C^- c^2}{m_C^+ c^2} \right]^{E,G} = 1$, pertinent for primordial Bivacuum, is dependent on 'longitudinal' and 'transverse' translational *external* velocities of BVF † , as it follows from (5.20) like:

$$K_{V^+ \Rightarrow V^-}^E = \left[\frac{m_C^- c^2}{m_C^+ c^2} \right]^E = 1 - \left(\frac{v_{\parallel tr}}{c} \right)^2 \quad 6.13$$

$$K_{V^+ \Rightarrow V^-}^G = \left[\frac{m_C^- c^2}{m_C^+ c^2} \right]^G = 1 - \left(\frac{v_{\perp tr}}{c} \right)^2 \quad 6.13a$$

At the Golden mean conditions, corresponding to contributions of zero-point longitudinal and transversal vibrations oscillations of elementary particles (see 5.34b and 5.34c) to Bivacuum fermions (BVF †) dynamics, we have in 6.13 and 6.13a:

$$\left(\frac{v_{\parallel tr}}{c}\right)_{\phi}^2 = \alpha\phi \quad \text{and} \quad \left(\frac{v_{\perp tr}}{c}\right)_{\phi}^2 = \beta\phi \quad 6.13b$$

The equilibrium constants of secondary Bivacuum, related to fields, generated by particles (5.56 and 5.57) have the reverse dependence with those, generated by antiparticles:

$$\tilde{K}_{V^+ \rightleftharpoons V^-}^{G,E} = 1/K_{V^+ \rightleftharpoons V^-}^{G,E} \quad 6.14$$

The modulated frequencies of 3D virtual pressure waves (VPW $^{\pm}$), forming VR S,R of condensed matter of (S) and (R), activated by [C \rightleftharpoons W] pulsation of pairs [F $_{\uparrow}^- \rightleftharpoons$ F $_{\uparrow}^+$] of triplets <[F $_{\uparrow}^- \rightleftharpoons$ F $_{\uparrow}^+$] + F $_{\uparrow}^{\pm}$ >, are the result of following combinations of frequencies of molecular librations (Ω_{lb}) and translations (Ω_{tr}):

$$[\omega_{VPW^{\pm}}(S)] = [q\omega_{C \rightleftharpoons W} + r\Omega_{lb} + g\Omega_{tr}]_S \quad 6.15$$

$$[\omega_{VPW^{\pm}}(R)] = [q\omega_{C \rightleftharpoons W} + r\Omega_{lb} + g\Omega_{tr}]_R \quad 6.15a$$

$$p, q, g = 1, 2, 3 \dots (\text{integer numbers})$$

The consequence of *nonlocal wave-guide (VirWG) of virtual photons* formation between [S] and [R] with ($\mathbf{H}_{in} \gg \mathbf{H}_{ext}$; $\mathbf{n}_{in} > \mathbf{n}_{ext}$) and overlapping of VR S and VR R on the atomic and molecular levels should affect the difference in probability of virtual particles and antiparticles origination - annihilation. This phenomena can be responsible for the **charge screening** effects in matter. These effects displays themselves in the spectral Lamb shifts and changing the atomic and molecular polarization, leading in turn, *to change of Van der Waals interactions between atom and molecules in condensed matter*.

Another possible approach to detect Bivacuum perturbation is a precise measurement of Casimir effect (Lamoreaux, 1997; Mohideen and Roy, 1998), very sensitive to vacuum virtual pressure. The value and sign of Casimir effect is determined by difference between the external as respect to conducting surfaces and internal effective virtual pressure.

This kind of [S+R] interaction can be modulated by selected vibrations of molecules of [S]. It means possibility of modulation of Bivacuum permittivity (ϵ_0) and permeability [$\mu_0 = (\epsilon_0 c^2)^{-1} = f(\Omega^R)$] by (S), affecting all kinds of electromagnetic intra- and inter-molecular interactions in (R).

Spatial stability of complex systems: atoms, molecules and that of solids means that in these systems superposition of CVC, representing [W] states of uncompensated sub-elementary particles, as well as VPW $^{\pm}$, radiated by pairs [F $_{\uparrow}^- \rightleftharpoons$ F $_{\uparrow}^+$] forms hologram - like 3D standing virtual waves superposition with location of nodes in the most probable positions of corpuscular phase of the nucleons, electrons, atoms and molecules in condensed matter. The binding of CVC by Bivacuum fermions (BVF †) restore the [C] phase of particles in positions, close to the most probable ones. So, the coherent atoms/molecules thermal oscillation in composition of clusters, representing mesoscopic Bose condensate (Kaivarainen, 2001b,c), should be strictly correlated with coherent [C \rightleftharpoons W] pulsations of their elementary particles. The opposite statement also is correct. The [C \rightleftharpoons W] decoherence and destabilization of coherent clusters of atoms and molecules in condensed matter, induced, for example by external fields or laser beam, may induce destruction of material.

It is obvious that parameters of VR S of Mind/Brain in form of multidimensional quantum hologram (QH S), formed by superposition of VPW $_{BV}^{\pm}$ of Bivacuum and those, generated by matter VPW $_M^{\pm}$ is much more variable (for example, dependent on intention) than VR of regular condensed Matter. The parameters of VR S are dependent of human will, meditation and are more adjustable for maximum effect of Mind-Matter interaction. However, the physical principles of Matter-Matter and Mind-Matter interaction (telekinesis, remote vision), as well as of Mind-Mind interaction (telepathy) are the same - macroscopic quantum entalgement, based on Principle of

least action and information/energy exchange in form, described above.

7. Bivacuum mediated Mind-Matter and Mind-Mind Interaction. Virtual Replicas of Matter and Temporal effects

It follows from our approach, that the formation of Bivacuum Psi-channel between sender [S] and receiver [R] needs three interrelated process, representing the coarse and fine $[S] \rightleftharpoons [R]$ tuning, correspondingly:

I. Targeting the [R] by [S], as a result of nonlocal virtual wave-guide (*VirWG*) formation between [S] and [R], based on Principle of least action in form 6.12 and 6.12a, for spatially directed exchange of information and electromagnetic energy between [S] and [R].

This process includes the counterphase superposition of virtual pressure waves (VPW^\pm) and virtual spin waves ($VirSW^\pm$), forming *wave-guide*, the electromagnetic and gravitational waves of particles, participating in elementary acts of perception and consciousness/subconsciousness of Mind [S] and similar waves of Matter [R] or another Mind [R]. It is a condition for creation of *virtual standing waves* between [S] and [R] of four types: *nonlocal virtual spin waves* ($VirSW_S^\pm \rightleftharpoons VirSW_R^\pm$), *virtual pressure waves* ($VPW_S^\pm \rightleftharpoons VPW_R^\pm$), *electromagnetic* ($EW_S^\pm \rightleftharpoons EW_R^\pm$) and *gravitational waves* ($GW_S \rightleftharpoons GW_R$).

Such a complex process of Psi-channel formation is modulated by few hierarchical levels of dynamics:

- a) counterphase correlation of 'flickering' of water clusters (mBC) in microtubules, accompanied by their [assembly \rightleftharpoons disassembly] with frequency of about 10^7 Hz;
- b) counterphase correlation of the electrons, protons and anions collective dynamics in a course of transport across the neurons and axons membranes, accompanied their excitation/depolarization in [S] and [R] systems. The corresponding oscillation of the huge gradient of electric tension in membranes ($100.000 \rightleftharpoons 0$) V/cm provides the conditions of alternating acceleration of charged particles inside and at vicinity of the membranes, necessary for bremsstrahlung, like in undulator and synchrotron radiation (see eqs. 6.29 - 6.34).;

II. The frequency synchronization, as a result of the neurodynamics processes in [S] and [R] 'tuning', resulting in $[v_S \rightarrow v_R]$, as a condition of (5.49 and 5.49a) via channels:

$VirWG_S \rightleftharpoons VirWG_R$. and $VPW_S^\pm \rightleftharpoons VPW_R^\pm$. This process may include a few stages:

- a) the synchronization of electroencephalogram, reflecting low frequency (8 - 10 Hz) brain rhythm of [S] and [R], enhanced by Schumann and other nonlocal geomagnetic and cosmic flicker noise;
- b) synchronization of frequency of neuron ensembles firing with frequencies about 40 Hz;
- c) synchronizations of elementary acts of consciousness (Kaivarainen, 2001), described in previous chapter of this paper, including [gel-sol] transitions;
- d) synchronization between $[C \rightleftharpoons W]$ pulsation of elementary particles of [S] and [R], i.e. 'tuning' of Virtual replicas of sender and receiver: $(VR)^S$ and $(VR)^R$ under the influence of Harmonization force (HaF) of Bivacuum (6.8);

III. Information and energy exchange between [S] and [R]. The information in form of phase or spin exchange may occur by variation of following parameters:

- a) the instant phase shift between nonlocal $VirSW_S$ and $VirSW_R$ (i.e. spin state of unpaired sub-elementary particles in protons, neutrons and electrons) and superposition of Virtual Replicas of [S] and [R];
- b) amplitude of VPW_S^\pm (proportional to fraction of molecules/atoms/elementary particles in state of mesoscopic Bose condensation (mBC));
- c) frequencies: the basic frequency (6.3e): $\omega_{C \rightleftharpoons W} = m_C^+ v^2 / \hbar$ and combinational frequencies: see eqs. 6.15 and 6.15a.

For explanation of different Psi phenomena the notion of nonlocal virtual wave-guide (**VirWG**) formed by $VirSW$ has been introduced. The **VirWG** has a bigger internal magnetic field and refraction index than the external one ($\mathbf{H}_{in} > \mathbf{H}_{ext}$; $\mathbf{n}_{in} > \mathbf{n}_{ext}$), making it possible the

strictly directed transmission of the electromagnetic energy between [S] and [R]. This model, including elements of the instant (phase) and luminal (energy) signals transmission, resembles the mechanism of *quantum teleportation* (Bouwmeester et al. 1997; Marcer, 2001).

Each Virtual Replica (VR) - 'phantom' of matter can be subdivided to the:

- 1) *internal-local* (VR^{in}) and
- 2) *external* (VR^{ext}) contributions of two kinds.

The *internal-local* contribution of VR^{in} represents superposition of cumulative virtual clouds (CVC) of all elementary particles in the volume of condensed matter, corresponding to their [W], responsible for strong, weak and electromagnetic interaction. This includes nuclear, covalent, H-bonds, ion-ion, ion-dipole and other Van der Waals interaction.

The *external* VR^{ext} contribution has a properties of *quantum hologram*, containing two modulated by matter inseparable components: the *distant* (VR_{dis}^{ext}) and *nonlocal* (VR_{nl}^{ext}) one.

The superposition/modulation of virtual pressure waves of Bivacuum (Bv) [VPW_{Bv}^{\pm}] by virtual pressure waves, generated by elementary particles of matter (M) [VPW_M^{\pm}], results in formation of distant (VR_{dis}^{ext}). The *primary* modulation of VPW_{Bv}^{\pm} by matter is a result of superposition of virtual clouds (VC^{\pm}) $_{Bv}$ of Bivacuum with virtual clouds (VC^{\pm}) $_M$, emitted and absorbed in a course of [$C \rightleftharpoons W$] pulsation of symmetric pairs [$F_{\uparrow}^{-} \rightleftharpoons F_{\uparrow}^{+}$] of elementary particles of Matter.

In turn, the *secondary* modulation of pulsation frequency $\omega_{C \rightleftharpoons W}$ and VPW_M^{\pm} occurs with frequency ($\Omega_{tr,lb}$) of *coherent vibrations* (translations, librations) of atoms and molecules of matter.

The distant VR_{dis}^{ext} realize the *amplitude/frequency correlation* between [$C \rightleftharpoons W$] pulsation of particles of [S] and [R].

The modulation frequency of thermal molecular vibrations of matter, occurs with frequency of translations and librations ($\Omega_{tr,lb}$). This nonlocal component of virtual replica of matter (VR_{nl}^{ext}) realize the *counter-phase correlation* of [$C \rightleftharpoons W$] pulsation of elementary particles of sender [S] and receiver [R] and secondary modulation of their VR^S and VR^R in the process of quantum entanglement described above.

Consequently, VR_{nl}^{ext} and VR_{dis}^{ext} are responsible, correspondingly, for the phase and amplitude/frequency signals transmission between [S] and [R] in the process of quantum teleportation. This would permit the virtual hologram's patterns exchange in the process of Matter-Matter, Mind-Matter and Mind-Mind (telepathy) interaction.

It is supposed, that *between external and internal virtual replicas* strong interdependence is existing, providing feedback reaction, like ($VR^{in} \rightleftharpoons VR_{dis,nl}^{ext}$).

The degree of deviation of external virtual replica VR^{ext} of any condensed matter from Bivacuum 'noise' is dependent on dimensions, number and dynamic correlation of coherent clusters of atoms/molecules in quantum state of mesoscopic Bose condensate [mBC] in this matter (Kaivarainen, 2000; 2001). The [mBC] may exist in proteins, DNA, membranes, water (especially in microtubules), chromosomes, bones and any other kind of condensed matter, as it shown in our Hierarchic theory of condensed matter.⁷ The VR^{ext} of *complex systems* of Matter represents the hierarchy of VR^{ext} of their *subsystems*.

After our Unified Model, the energy/informational exchange interaction between Sender and Receiver involves three following dynamic processes:

1. Superposition of Virtual Spin Waves (VirSW) in Bivacuum between [S] and [R], activated by rotational momentum ($p_{rot} = m_0\omega_0L_0$) of cumulative virtual clouds (CVC_{\uparrow}^{\pm} and CVC_{\downarrow}^{\pm}), *emitted* \rightleftharpoons *absorbed* in the process of [$C \rightleftharpoons W$] pulsation of uncompensated F_{\uparrow}^{\pm} $_S$ and F_{\uparrow}^{\pm} $_R$ of [Sender] and [Receiver], with the rest mass energy:

$$\mathbf{E}_{VirSW} = \mathbf{m}_0\mathbf{c}^2 = \mathbf{m}_0\omega_0^2\mathbf{L}_0^2 = \mathbf{p}_{rot}^2/\mathbf{m}_0 \quad 7.1$$

$$\text{where : } \omega_0 = \mathbf{m}_0\mathbf{c}^2/\hbar; \quad \mathbf{L}_0 = \hbar/\mathbf{m}_0\mathbf{c}; \quad \mathbf{p}_{rot} = \mathbf{m}_0\omega_0\mathbf{L}_0$$

The dynamic spin equilibrium [$BVF^{\uparrow} \rightleftharpoons BVF^{\downarrow}$] is very sensitive to magnetic fields and

rotational momentums of cumulative virtual clouds (CVC $^{\pm}$), emitted by sub-elementary particles, as a result of $[C \rightarrow W]$ transitions. The equilibrium constant:

$$\mathbf{K}_{BVF^{\uparrow} \rightleftharpoons BVF^{\downarrow}}(\mathbf{t}) = \exp\left(-\frac{\varepsilon_{BVF^{\uparrow}} - \varepsilon_{BVF^{\downarrow}}}{U_H^{eq}}\right) \quad 7.2$$

where: U_H^{eq} is the equilibrium energy of Bivacuum 'noise', induced by external spin field and EM fields;

$$\varepsilon_{BVF^{\uparrow}}(t) = \vec{\mu}_{BVF^{\uparrow}} \vec{H}(t) \quad 7.3$$

$$\varepsilon_{BVF^{\downarrow}}(t) = \vec{\mu}_{BVF^{\downarrow}} \vec{H}(t) \quad 7.3a$$

are the instant values of energies of BVF^{\uparrow} and BVF^{\downarrow} in fluctuating magnetic field (\vec{H}).

The oscillations of $K_{BVF^{\uparrow} \rightleftharpoons BVF^{\downarrow}}(t)$ represent virtual spin waves (VirSW), transferring the information in Bivacuum without transmission of momentum and energy.

Corresponding massless nonlocal collective modes in Bivacuum in form of oscillation of degeneration parameter have similarity with Nambu-Goldstone (NG) bosons, introduced in quantum field theory (QFT).

A standing nonlocal Virtual Spin waves [$\mathbf{VirSW}_S^{\pm} \rightleftharpoons \mathbf{VirSW}_R^{\pm}$], forming virtual wave-guide (\mathbf{VirWG}^{\pm}) between unpaired sub-elementary particles/antiparticles, can channel the electromagnetic energy between [S] and [R];

2. The Bivacuum symmetry longitudinal and transversal oscillations (BvSO) $_{\parallel}$ and (BvSO) $_{\perp}$, responsible for electromagnetism and gravitation, correspondingly, accompanied $[C \rightleftharpoons W]$ pulsation of uncompensated sub-elementary particles of triplets $\langle [\mathbf{F}_{\uparrow}^{-} \bowtie \mathbf{F}_{\downarrow}^{+}] + \mathbf{F}_{\uparrow}^{\pm} \rangle$ of [S] and [R]. The correlation and minimization of these kinds of translational dynamics means realization of Principle of least action in accordance to our formula (6.10 and 6.10a);

3. Different kinds of standing waves superposition between Virtual Replicas (VR) $_{S,R}$ of Sender [S] and Receiver [R] are presented in Table 2.

TABLE 2
Contributions to superposition of Virtual Replicas of [S] and [R]
 $[\mathbf{VR}_S \rightleftharpoons \mathbf{VR}_R]_{ext}$
of different kinds of standing waves, excited by $[C \rightleftharpoons W]$ pulsation
of pairs $[\mathbf{F}_{\uparrow}^{-} \bowtie \mathbf{F}_{\downarrow}^{+}]$ of triplets $\langle [\mathbf{F}_{\uparrow}^{-} \bowtie \mathbf{F}_{\downarrow}^{+}] + \mathbf{F}_{\uparrow}^{\pm} \rangle$:

$[\mathbf{VirSW}_S^+ \rightleftharpoons \mathbf{VirSW}_R^+]$ – virtual spin waves (+)
$[\mathbf{VPW}_S^+ \rightleftharpoons \mathbf{VPW}_R^+]_{ext}$ – virtual pressure waves (+)
$[\mathbf{GW}_S^+ \rightleftharpoons \mathbf{GW}_R^+]$ – gravitational waves (+)
$[\mathbf{EW}_S^+ \rightleftharpoons \mathbf{EW}_R^+]$ – electromagnetic waves (+)
$[\mathbf{F}_{\downarrow}^+]$
\Updownarrow
$[\mathbf{F}_{\uparrow}^-]$
$[\mathbf{VirSW}_S^- \rightleftharpoons \mathbf{VirSW}_R^-]$ – virtual spin waves (-)
$[\mathbf{VPW}_S^- \rightleftharpoons \mathbf{VPW}_R^-]_{ext}$ – virtual pressure waves (-)
$[\mathbf{GW}_S^- \rightleftharpoons \mathbf{GW}_R^-]$ – gravitational waves (-)
$[\mathbf{EW}_S^- \rightleftharpoons \mathbf{EW}_R^-]$ – electromagnetic waves (-)

This set of standing waves also is responsible for Bivacuum mediated interaction between Sender [S] and Receiver [R].

This interaction may be accompanied by change of Bivacuum permittivity ($\pm\Delta\epsilon_0$) and permeability ($\pm\Delta\mu_0$). Corresponding changes in Van der Waals interactions modulate the probability of thermal fluctuations in condensed matter like water.

The cosmic and secondary atmospheric neutrino, propagating through each cell of sender [S] and receiver [R] from both sides, also may participate in formation of Psi-channel. These neutrinos, modulated by scattering on the electrons and protons of the nerve cells membranes, also may serve as a carrier of information exchange between [S] and [R].

The double membranes of the coherent nerve cells may provide the cumulative Casimir effect, modulating the Virtual Replica of [S] and [R].

The quantum neurodynamics processes in Sender (Healer) may be accompanied by radiation of electromagnetic waves or magnetic impulses, propagating in Bivacuum via virtual wave-guide: $\mathbf{VirSW}^S \rightleftharpoons \mathbf{VirSW}^R$. Such kind of radiation from different regions of Sender/Healer has been revealed experimentally (see section 7.3).

The feedback reaction between virtual replicas of receiver and sender (target): $\mathbf{VR}^R \rightarrow \mathbf{VR}^S$ is a background of remote vision (RV).

The important role in Bivacuum mediated Mind-Matter and Mind-Mind interaction, plays the coherent fraction of water in **microtubules** of neurons in state of *mesoscopic molecular Bose condensate (mBC)* (Kaivarainen, 2000; 2001). This fraction of **mBC** is a variable parameter, dependent on structural state of microtubules and number of simultaneous elementary acts of consciousness (Kaivarainen, 2000, 2001). It can be modulated not only by excitation of nerve cells, but also by specific interaction with virtual replica of one or more chromosomes (\mathbf{VR}^{DNA}) of the same or other cells.

The change of frequency of selected kind of thermal fluctuations, like cavitational ones, in the volume of receiver [R], including cytoplasm water of nerve cells, is accompanied by reversible disassembly of microtubules and actin' filaments, i.e. [gel \rightleftharpoons sol] transitions. These reactions, responsible for elementary act of consciousness (Kaivarainen, 2000; 2001), are dependent on the changes of corresponding activation barriers.

*The mechanisms of macroscopic quantum entanglement, proposed in our work, is responsible for change of intermolecular Van der Waals interaction in the body of [R] and probability of selected thermal fluctuations (i.e. cavitational fluctuations), induced by [S]. In this case, realization of certain series of elementary acts of consciousness of [S] will induce similar series in nerve system of [R]. This means informational exchange between \mathbf{VR}^R and \mathbf{VR}^S , i.e. **telepathy**. The *individual character* of telepathic signal transmission from [S] to [R] may be provided by modulation of \mathbf{VR}_{MT}^S of microtubules by \mathbf{VR}_{DNA}^S of DNA of sender's chromosomes in neuron ensembles, responsible for subconsciousness, imagination and consciousness.*

In accordance to our theory of elementary act of consciousness, the modulation of [assembly \rightleftharpoons disassembly] of microtubules due to cavitational fluctuations in the nerve cells and corresponding [gel \rightleftharpoons sol] transitions by directed mental activity of [Sender] can provide telepathic contact between [S] and [R]. The mechanism of remote healing could be the same, but the local targets in the body of patient [R] should be not necessarily the MTs of nerve cells, but MTs or microfilaments, like actin fibers in cells of the ill organs, which also have their 'ether body' - internal virtual replica, and can be targeted by healer.

The specific magnetic component of Psi-channel is generated by the nerve impulse propagation along the axons and depolarization of nerve cells membranes in 'tuned' ensemble of neuron cells. This **H**-component can modulate the magnetic field and, consequently, the refraction index of the internal region of virtual wave guide (VirWG). In turn, this modulate the electromagnetic energy exchange between [S] and [R], responsible for targeting in Remote Vision (RV), Remote Healing (RH) and other Psi-phenomena.

The Psi-channel between [S] and [R] works better, if the frequencies of geomagnetic Schumann waves - around 8 Hz (close to brain waves frequency) and other cosmophysical macroscopic fluctuations, are the same in location of [S] and [R], providing conditions of coherency between them.

TABLE 3

The role of different sub-elementary particles
of the electron's [Corpuscle \rightleftharpoons Wave] pulsation:

$$\langle [\mathbf{F}_{\uparrow}^+ \bowtie \mathbf{F}_{\downarrow}^-]_W + (\mathbf{F}_{\uparrow}^-)_C \rangle \rightleftharpoons \langle [\mathbf{F}_{\uparrow}^+ \bowtie \mathbf{F}_{\downarrow}^-]_C + (\mathbf{F}_{\uparrow}^-)_W \rangle$$

in virtual channel formation between sender [S] and receiver [R]

Pair of sub-elementary particle and antiparticle pulsation:	Uncompensated sub-elementary particle pulsation:
$[\mathbf{F}_{\uparrow}^+ \bowtie \mathbf{F}_{\downarrow}^-]_W \rightleftharpoons \langle [\mathbf{F}_{\uparrow}^+ \bowtie \mathbf{F}_{\downarrow}^-]_C \rangle$	$(\mathbf{F}_{\uparrow}^+)_C \stackrel{BvSO}{\rightleftharpoons} (\mathbf{F}_{\uparrow}^+)_W \stackrel{CVC\cup\cup}{\rightleftharpoons} \mathbf{VirSW}^{\cup\cup}$
1. Virtual Pressure Waves:	1. Electromagnetic potential:
$\mathbf{VPW}^+ \bowtie \mathbf{VPW}^-$	$\mathbf{E}_{EM} = \alpha \mathbf{m}_C^+ \mathbf{v}^2 = \mathbf{m}_C^+ \mathbf{v}_{tr,\parallel}^2$
2. Virtual Replica of Matter (VR)	2. Gravitational potential:
3. The excessive Virtual Pressure:	$\mathbf{E}_G = \beta \mathbf{m}_C^+ \mathbf{v}^2 = \mathbf{m}_C^+ \mathbf{v}_{tr,\perp}^2$
$\Delta \mathbf{VP}^{\pm} = \mathbf{VP}_{\mathbf{F}_{\uparrow}^+}^+ - \mathbf{VP}_{\mathbf{F}_{\downarrow}^-}^- $	3. Virtual Spin Waves (VirSW):
4. Hydrodynamic virtual	$\mathbf{E}_S = \mathbf{E}_0 = \mathbf{m}_0 \omega_0^2 \mathbf{L}_0^2 = \mathbf{m}_0 \mathbf{c}^2 =$
Bjornkess force	$= \mathbf{m}_C^+ \mathbf{v}^2 - \alpha \mathbf{m}_C^+ \mathbf{v}^2 - \beta \mathbf{m}_C^+ \mathbf{v}^2$
(attraction or repulsion)	(attraction or repulsion)
5. Superposition of Virtual Replicas of Sender and Receiver: $\mathbf{VR}_S \approx \mathbf{VR}_R$	4. Virtual wave-guide of photons
	(VirWG) with $n_{in} > n_{ext}$
	between [S] and [R]

One of the result of Virtual-channel formation is a change of permittivity ϵ_0 and permeability μ_0 of Bivacuum [$\epsilon_0 = 1/(\mu_0 c^2)$]. In turn, ($\pm \Delta \epsilon_0$) influence Van-der-Waals interactions in condensed matter, changing the probability of defects origination in solids and cavitational fluctuations in liquids. Bidirectional change of pH of water under Psi field action can be a consequence of $\pm \Delta \mathbf{VP}^{\pm}$ and $\pm \Delta \epsilon_0$ influence on cavitational fluctuations, accompanied by shift of dynamic equilibrium:

$$H_2O \rightleftharpoons HO^- + H^+$$

Changing the density and energy of virtual particles in nuclears of atoms, induced by Psi field, may be resulted also in modulation of radioactive decay

The coherency of all components of Virtual waveguide between [S] and [R], formed by nonlocal virtual spin waves (\mathbf{VirSW}^{\cup} and \mathbf{VirSW}^{\cup}) of two opposite angular moments and virtual pressure waves (\mathbf{VPW}^+ and \mathbf{VPW}^-) of two opposite energies, corresponds to finest tuning of mind-matter and mind-mind interaction. The coherency between signals of [S] and [R] partly can be provided by modulation of virtual wave-guide/channel by cosmic/geophysical magnetic flicker noise.

The [dissociation \rightleftharpoons association] equilibrium oscillation of coherent water clusters in state of molecular Bose condensate (mBC) in microtubules of nerve cells, modulating ($\mathbf{VirSW}^{\cup,\cup}$) and

VPW[±], is a crucial factor for realization of quantum Psi phenomena. The virtual replica of MTs can be modulated also by VR (phantom) of DNA.

7.1 Explanation of Bivacuum mediated genetic information exchange between distant cells and different organisms

In accordance to our Unified Model, all material objects, from elementary particle to planets and stars, including biosystems like macromolecules, cells, organs, animals, etc. has very complex hierarchical virtual replicas, roughly subdivided to internal and external ones. Some components of VR are the carriers of information and spin (VirSW) and some of them ($\Delta VP = |\mathbf{VP}^+ - \mathbf{VP}^-|$, \mathbf{E}_E , \mathbf{E}_G) can carry the momentum and energy.

The virtual replica ($VR_{DNA}^{S,R}$) of highly ordered parts of the eukaryote's chromosomes (introns), not participating directly in biosynthesis and including more than 95% of total DNA, may play the active and very specific role in the [Mind-Matter] and [Mind-Mind] interaction. The so-called *nucleosomes* represent long parts of DNA, tuned around the histone octamer. The diameter of such nucleosomes (stable nuclear-protein complexes) is about 110 Å. The histones are able to modulate the DNA structure and functions. In accordance to our Hierarchic theory of condensed matter (Kaivarainen, 2000; 2001), the high density and stability of nucleosomes and native chromosomes provides condition for mesoscopic Bose condensation [mBC] at ambient temperature in their volume. The [mBC] may exist in form of so-called *primary translational and librational effectons*, representing 3D standing de Broglie waves of atoms/molecules of condensed matter (chromosomes in private case).

The existence of [mBC] and their coherent [$C \rightleftharpoons W$] pulsation, allows the *macroscopic quantum entanglement between chromosomes and microtubules* of distant cells and even between different organisms with similar properties of their molecular Virtual Replica (VR), as between [S] and [R].

It leads from our model, that the *synchronization of the interacting chromosomes dynamics by coherent photons of certain frequency and polarization*, should enhance the effect of quantum entanglement and interaction of their (VR^S and VR^R), because of induced combinational resonance.

Synchronization and spatial polarization of uncompensated virtual pressure waves:

$$\Delta VPW = |\mathbf{VPW}^+ - \mathbf{VPW}^-| \sim \Delta VP$$

activated by [$C \rightleftharpoons W$] pulsation of elementary particles of chromosomes of *organisms-senders* (S) and *organisms - receivers* (R) can be provided by *polarized* electromagnetic (EM) waves, propagating through the virtual wave guides (**VirWG**), formed by virtual spin waves (**VirSW**) between [S] and [R]. The length of these EM waves are determined by dimensions of interacting organisms and distance between them, i.e. the order of meters for animals and human beings. These conditions point to radio-frequency of EM waves: $(10^4 \div 10^8) \text{ s}^{-1}$, generated by coherent fluctuations of density and dipole moment of DNA and microtubules, carrying such function.

This consequence of our Unified model of Bivacuum and quantum entanglement between synchronized particles of certain spatial relative orientation can be considered, as a physical background for distant transmission of genetic information between cells (donors-senders) and cells (acceptors-receivers) of different organisms, revealed by Dzang Kangeng (1992; 1993) and Gariaev's group (2002)⁴¹, activated by special optoelectronic equipment.

Dzang Kangeng (1992; 1993) used hexahedron, cone, sphere and a parabolic-reflector aerial, as a kind of forms, providing specific spinning (polarization) of the electromagnetic (EM) field. In the D. Kangeng's equipment the high-frequency generator of two orthogonally-polarized electromagnetic beams has been used, which repeatedly pass through the donor and the accepting biosystems, necessary for informational exchange between them. All known biopolymers are optically active, sometimes in very specific way. Consequently, polarization of photons should increase the effectiveness of interaction of chromosomes with coherent photons, dependent also on their frequency and density. It is obvious that *polarization modulation* of electromagnetic

beam by sender [S] (donor), should influence the quantum and small-scale dynamics of DNA of receiver [R] (acceptor) and, consequently on its VR^R.

In Gariaev's version of Dzang Kangeng's device, the **polarized laser visible beam** ($\lambda = 632 \text{ nm}$) transforms to *coherently polarized radio waves* (PLRW) of frequency range: $(10^3 - 10^6) \text{ s}^{-1}$. This effect is explainable in the framework of our Hierarchic theory of condensed matter (see section 1 of this paper and Kaivarainen, 2000; 2001), as a consequence of stimulated by laser photons transitions (fluctuations) of coherent groups atoms in state of mesoscopic Bose condensation (mBC) in composition of nucleosomes. Such kinds of collective excitations, named *convertons, macrodeformons and superdeformons, are accompanied by radiation of EM-waves of (kHz - MHz) radio frequency* (see section 1 of this paper and Kaivarainen, 2000a). This device, like that of Dzang Kangeng, is shown to be able to transfer the genetic information between different organisms and distant cells of the same organism. This information may be related not only to gene-controlled biosynthesis, but also to *generation of still mysterious morphogenetic field*, responsible for spatial organization of the cells in organs and organs in organisms.

The spontaneous radiation of coherent 'biophotons' by DNA of wide frequency range has been revealed earlier by Gurvich (1977) and Popp (2000). Corresponding visible photons also may be converted in radio waves, as a result of collective modes excitation, even without external source of EM energy.

I put forward a conjecture, that the interaction between virtual replicas (VR) of distant cells of the same eucaryotic organisms may be responsible for self-reparation/regeneration of the damaged cells. Two orthogonally-polarized electromagnetic (IR) beams radiated by microtubules of two orthogonal centrioles may form a hologram-like 3D system of standing waves. The frequency, intensity and polarization of such IR hologram could be modulated by Virtual Replica and EM radiation of DNA of the same cells. It is assumed, that EM radiation and VR of 'healthy' cells influence the water surrounding and structure of damaged DNA of other cells, activate the enzymes, repairing the damaged DNA structure and finally the cells function. The high energy ($T_{cav} \sim 6000 \text{ K}$) of stimulated by modulated EM radiation cavitation fluctuations of the vicinal to DNA water can be used for the local rearrangements of chemical bonds between nucleotides of DNA.

The accumulating of experimental facts, pointing to possibility of genetic information exchange between different cells of the same organisms and even different organisms by means of polarized and modulated EM waves, may change our conventional paradigm of genetics and biological evolution drastically. The 'Wave Genetics' - term, introduced by Peter Gariaev, can have the huge impact on biotechnology, using experimentally confirmed possibilities of genetic reparation and hybridization by transmitting the information and energy between different kinds of plants and animals in form of specifically modulated polarized EM radiation.

The data, pointing to possibility of 'healing' of different species of the same populations, like bacteria and insects, are existing also. In such experiments one group of population, poisoned by antibiotics survived, if it was nearby to healthy population of the same organisms. Our theory may explain this effect by resonant interaction between Virtual Replicas (VR) of healthy and poisoned populations of bacteria (Parsons and Heal, 2002) and insects (Agadjanian, 2003) inducing the reparation of 'ill' organisms. The exchange between VR of DNA of these two groups of living organisms may contribute to process of distant healing.

Kaznachev (1986) was conducted the extensive studies of informational exchange between living cells.

The possibility of telepathic communication between the same population of animals (rabbits) also was demonstrated (Gurtovoy, 2002). Electrodes were implanted in the brain of rabbit - 'sender' and in brain of 'receiver' rabbits, separated to distance about 7 km. Stimulation of 'sender' by electric pulses, setting the rabbit to state of alert induces the statistically significant response currents in brains of 'receiver' rabbits.

Like in the case of identical elementary particles, the interaction between spatially identical and dynamically coherent chromosomes/DNA may occur by means of the external Virtual

Replicas (VR_{ext}) and virtual wave guides (VirWG). Such specific virtual channels between [DNA-Sender] and [DNA-Receiver], formed due to realization of principle of Least action, can be responsible for the spin/polarization (i.e. information) and virtual photons (energy) exchange.

7.2 The examples of Virtual Channel (VC) action between Sender [S] (psychic) and targets [R]: physical fields and matter

There are following examples, collected by Savva [18] of how the Psi - virtual channel, generated by gifted psychic - 'Sender' [S], can interfere with real physical fields and targets [R]: nonbiological (like water) and biological ones:

- speeding up and slowing down the rate of americium 241Am nuclear decay - point to interference of Psi-field with nuclear fields;
- rotation of the plane of polarization of laser beam by 7-30° points to interference of Psi field with electromagnetic field;
- deviation of the electrical resistance of a thermoresistor;
- induction of a periodic electrical signal from a piezoelectric sensor;
- induction of a pulse magnetic field (100 nT and up to 27x10⁶ nT), accompanied by rotation of a compasses needle;
- moving the plate of an encased precise analytical balance equivalent to 100 mg force point to influence of Psi-field on gravitation.
- induction of a temporary peak in the Raman spectrum of tap water at 2200 cm⁻¹;
- temporary changes in the microstructure of water as observed through scattering of laser beam ($\lambda = 632.8$ nm) at various angles;
- deviation of UV adsorption spectra of DNA - water solution in the area of 220- 280 nm in three independent observations;
- predetermined deviation from randomness with high probability of various random number generators has been revealed in Princeton group;
- increase of the concentration of dislocations (missing atoms in microcrystalline structure) in "metal bending" experiments with local increase of surface hardness.

Water treated with a magnetic field, like intent-imprinted water, has stimulating effect on plant growth.

The IR spectra of water, its surface tension and crystallization patterns are similar for both types of water treatment.²⁰

Marcel Vogel²¹ claimed that quartz crystals of certain shape could amplify the mental intent action on water. He demonstrated that in water, circulating around an intent-charged crystal, the following changes are revealed:

decreasing in surface tension, increasing of conductivity, a significant drop in the freezing point (as low as -30 degrees), bidirectional alterations in the pH up to 3 points; the appearance of two new bands in the IR and UV absorption spectrum, etc. Boiling of water after treatment shows no changes in the UV spectrum, so one can conclude that a permanent chemical change has taken place.

Dean and Brame found that healer treated water demonstrated changes with both IR spectrophotometry (indicating altered hydrogen bonding) and specific peaks with UV spectrophotometry. The half-life for these effects lasted from three days to as long as three years.

It was demonstrated, that the Psi-field (Bivacuum perturbation), as a carrier of information, cannot be significantly blocked by any physical screening and that the effect does not depend on the distance. The Psi-virtual channel seems to be non-isotropic, i.e. strictly spatially directed. For example, Ageev, Dulnev, Kolmakov, etc. (2003) revealed that good psychic (sender) is able selectively change the electric potential of the electrodes in the aqueous solution of sodium chloride (100 ml of 0.9% NaCl solution) in one of two vessels, separated from each other for 2 meters only. The distance between psychic and vessels was about 500 kilometers.

The same research group revealed the remote influence of psychic on direct magnetic field sensor (ferroprobe magnetometer), screened well from the external regular EM influence. The detector of alternating magnetic field did not revealed any significant changes, induced by remote

'sender'. Our virtual spin wave (VirSW) concept can explain these results.

Well registered phenomena of remote viewing and precognition by Hal Puthoff and Russel Targ at Stanford Research Institute¹⁹ are confirmed in other laboratories.

Numerous studies have demonstrated (Targ & Kutra, 1998) that size of the target (down to 1 mm square) and distance between sender [S] and target (up to 10,000 miles) do not appear to significantly impair signal perception.

The electromagnetic shielding by Faraday cage or sea water does not negatively impact remote viewing ability. *The fundamental quantum phenomena, related to vacuum - matter interaction, should be involved in these processes.*

7.3 The data, pointing to biological/biochemical aspects of Virtual Channel (VC) between Sender and Receiver action

There are two classes of distant healing: 1) when the target (Receiver) is found by the healer (Sender) on the basis of a name, location, birth date, etc. (in remote viewing terms, this is "coordinate") and 2) when the adjunct (an object previously treated by the healer, such as water, cloth, a crystal, etc.) is used by the patient with or without the healer's knowledge.

In a 1991 Chien & al. report that they found the following biochemical effects when studying the influence of a qigong master, generating Psi-field, on a culture of human fibroblasts: a 1.8% increase in cell growth rate in 24 hrs; 10-15% increase in DNA synthesis and 3-5% increase in cell protein synthesis in a 2 hr period.

When the master emitted "inhibiting" Psi-field, the cell growth decreased by 6%, while DNA and protein synthesis decreased by 20-23%, respectively 35-48%.

Intent-modulated emission of *biophotons* from the hands of qigong practitioners is a well-known phenomenon that has often been reported in the scientific literature. Eugene Wallace reported measuring up to 100 time stronger emissions from the hands of gifted persons compared to controls.

A study by Nakamura & al.²³ reports an increase in subject's hand biophotons intensity associated with a drop in skin surface temperature during Qigong practice. The significantly higher (up to 105nT) magnetic signals during Qi emission from hands of qigong practitioners, as compared to the controls were revealed (Lin & Chen, 2001).

It was proposed by Beal and Oschman²⁴ that, under special conditions, resonant brainwaves may entrain the body's neural system to deliver healing frequencies to diseased tissues, or become coupled to the Schumann resonance and thus transmit distant healing effects to the target. But even accepting the Schumann resonance as a non-dissipative mechanism of information transmission, we are still faced with the enigma of mental interactions that cannot be attributed to EM fields - such as the effects on internuclear and gravitational forces described above.

7.4 The physical basis for individual memory and sharing of mental images in remote viewing (RV) and telepathy

The stability of each new synaptic distribution in the ensemble of nerve cells, participating in elementary act of consciousness, is responsible partly for long-term memory. Each redistribution in neuron's system of brain and central nerve system is accompanied by modulation of previous *internal (ether) virtual replica* VR_{in} with hologram properties.

This part of our approach is close to idea of Karl Pribram about holographic nature of memory. The stability and coherency of the *ether* VR_{in} is related directly to stability and coherency of biological structures, responsible for memory on neurodynamics level.

The another - distant and nonlocal contribution to memory can be provided by concomitant to VR_{in} change of the mental and astral virtual external replicas (VR_{ext}) of human body, leading finally to specific perturbation of the Earth VR (EVR).

The stability of perturbation of EVR by new information, carried out by the external Virtual Replica (VR_{ext}), processed by brain, determines the stability of VR_{in} and corresponding memory.

It means that, if the coherent Virtual pressure waves (VPW[±]) of Bivacuum, as a result of interference with VR_{ext}, related to certain elementary act of consciousness and memorizing, can form a system of virtual standing waves, incorporated well in holographic structure of EVR, then we got a stable imprinting of idea or image or series of physical actions in Bivacuum.

However, there should be existing a kind of filters and thresholds, preventing 'downloading' to EVR and Superconsciousness the information in form of standing VPW[±], of already existing or 'destructive' info, destabilizing EVR. The principle of selection of "valuable" new information/perturbation could be based on criteria of Golden mean, as background principle of Bivacuum dynamic/spatial self-organization.

In accordance to Unified Model, the physical basis for sharing of mental images in remote viewing, telepathy and other transpersonal experiences is interaction between hierarchy of virtual replicas (between the individual ether VR and EVR) of 'sender or searcher' and 'receiver or target'. There are no principal difference between $[\sum VR_i]^R$ of the living object, as a target, and nonliving object in such phenomena, as remote viewing (RV). The living target makes difference in telepathy and remote healing. The Psi interaction between living objects is more 'tunable' and telepathic contact is possible due to feedback reaction.

The remote sensing of physical target is possible in Unified Model on the basis, described above as a result of Bivacuum-mediated interaction of nonlocal and distant components of Virtual Replicas of 'searcher' [S] and target.

The notion of "collective information" in Unified Model may be replaced by "cumulative, collective perturbation of the Universe Virtual Replica (UVR) and Superconsciousness (SC) of the Universe".

The Superconsciousness (SC) can be considered, as a Quantum Supercomputer, able to virtual processing of information, organizing it by certain principles with possibility of feedback action on the astral, mental and ether bodies (Virtual Replicas) of individuals or non biological objects, geophysical and cosmic processes, etc.

The idea of Universe with properties of "Even Bigger Computer" with ability to simulate future and memorizing past was proposed also by Tom Campbell (2003)³².

TABLE 4

**Self-organization and evolution of the Universe,
represented by complex system:**

{Bivacuum + Matter + Fields + Virtual Replicas of Matter (VR) + Consciousness}
under the influence of Bivacuum Harmonization Force [HaF]
can be presented as a following stages with feedback reaction:

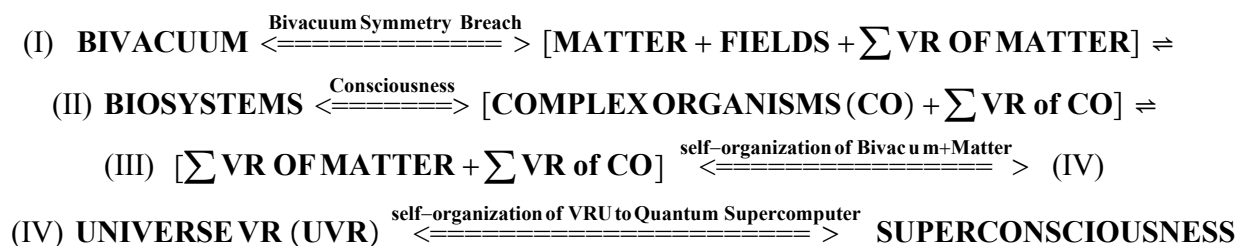

The important contribution to realization of Consciousness, as a self-organizing quantum supercomputer, on any level of matter organization is related to superposition of virtual pressure waves (VPW[±]), representing the collective excitations of sub-quantum particles. Interesting ideas, concerning the role of coherent systems of sub-quantum particles in Nature and various levels of Consciousness has been developed by Neil Boid [www.rialian.com/rnboid/p-consciousness].

The possibility of feedback reaction between *Superconsciousness* and

Individual Consciousness, leading from our concept, means that at proper conditions of high Universe Virtual Replica (UVR) instability (bifurcation point), even very small perturbation of GVR may influence Superconsciousness.

7.5 Temporal effects in evolution of Virtual Replicas

Let us analyze at first possible time effects in simplest virtual replica, generated by the pairs $[\mathbf{F}_{\uparrow}^- \bowtie \mathbf{F}_{\downarrow}^+]$ of triplets $\langle [\mathbf{F}_{\uparrow}^- \bowtie \mathbf{F}_{\downarrow}^+] + \mathbf{F}_{\uparrow}^{\pm} \rangle$. For this end we use the general formula for pace of time, obtained before (5.48):

$$\mathbf{d} \ln t^i = -\mathbf{d} \ln \mathbf{H} \mathbf{a} \mathbf{E}^i = -\mathbf{d} \ln (\mathbf{E}_E + \mathbf{E}_G)^i = -\mathbf{d} \ln [\alpha m_C^+ \mathbf{v}^2 + \beta m_C^+ \mathbf{v}^2]^i \quad 7.4$$

The differential virtual replica of triplet (ΔVR^{\pm}) can be presented as:

$$\Delta \text{VR}_{\mathbf{F}_{\uparrow}^- \bowtie \mathbf{F}_{\downarrow}^+}^{\pm} = \text{VR}_{\mathbf{F}_{\uparrow}^- \bowtie \mathbf{F}_{\downarrow}^+}^{\mathbf{F}_{\uparrow}^-} - \text{VR}_{\mathbf{F}_{\uparrow}^- \bowtie \mathbf{F}_{\downarrow}^+}^{\mathbf{F}_{\downarrow}^+}$$

In more detailed energetic presentation, taking into account interrelation between energies of unpaired $\mathbf{F}_{\uparrow}^{\pm}$ and paired sub-elementary particles (6.3b), this looks, like:

$$\begin{aligned} \Delta E_{\mathbf{F}_{\uparrow}^- \bowtie \mathbf{F}_{\downarrow}^+} &= \left| -E_{\mathbf{F}_{\uparrow}^- \bowtie \mathbf{F}_{\downarrow}^+}^{\mathbf{F}_{\uparrow}^-} \right| - \left| E_{\mathbf{F}_{\uparrow}^- \bowtie \mathbf{F}_{\downarrow}^+}^{\mathbf{F}_{\downarrow}^+} \right| = |-m_C^+ \mathbf{v}^2|_{\mathbf{F}_{\uparrow}^- \bowtie \mathbf{F}_{\downarrow}^+}^{\mathbf{F}_{\uparrow}^-} - |m_C^+ \mathbf{v}^2|_{\mathbf{F}_{\uparrow}^- \bowtie \mathbf{F}_{\downarrow}^+}^{\mathbf{F}_{\downarrow}^+} = \\ &= \alpha \left[|-m_C^+ \mathbf{v}^2|_{\mathbf{F}_{\uparrow}^- \bowtie \mathbf{F}_{\downarrow}^+}^{\mathbf{F}_{\uparrow}^-} - |m_C^+ \mathbf{v}^2|_{\mathbf{F}_{\uparrow}^- \bowtie \mathbf{F}_{\downarrow}^+}^{\mathbf{F}_{\downarrow}^+} \right] + \beta \left[|-m_C^+ \mathbf{v}^2|_{\mathbf{F}_{\uparrow}^- \bowtie \mathbf{F}_{\downarrow}^+}^{\mathbf{F}_{\uparrow}^-} - |m_C^+ \mathbf{v}^2|_{\mathbf{F}_{\uparrow}^- \bowtie \mathbf{F}_{\downarrow}^+}^{\mathbf{F}_{\downarrow}^+} \right] = \\ &= \left[(E_E)_{\mathbf{F}_{\uparrow}^- \bowtie \mathbf{F}_{\downarrow}^+}^{\mathbf{F}_{\uparrow}^-} - (E_E)_{\mathbf{F}_{\uparrow}^- \bowtie \mathbf{F}_{\downarrow}^+}^{\mathbf{F}_{\downarrow}^+} \right] + \left[(E_G)_{\mathbf{F}_{\uparrow}^- \bowtie \mathbf{F}_{\downarrow}^+}^{\mathbf{F}_{\uparrow}^-} - (E_G)_{\mathbf{F}_{\uparrow}^- \bowtie \mathbf{F}_{\downarrow}^+}^{\mathbf{F}_{\downarrow}^+} \right] \end{aligned} \quad 7.5$$

$$\text{or : } \Delta E_{\mathbf{F}_{\uparrow}^- \bowtie \mathbf{F}_{\downarrow}^+} = (\Delta E_E)_{\mathbf{F}_{\uparrow}^- \bowtie \mathbf{F}_{\downarrow}^+}^{\mathbf{F}_{\uparrow}^- - \mathbf{F}_{\downarrow}^+} + (\Delta E_G)_{\mathbf{F}_{\uparrow}^- \bowtie \mathbf{F}_{\downarrow}^+}^{\mathbf{F}_{\uparrow}^- - \mathbf{F}_{\downarrow}^+} \quad 7.5a$$

Using (7.4), we can see, that the pace of time in such differential virtual replica is determined by the sign of relative changes of difference between the electromagnetic and gravitational potentials of \mathbf{F}_{\uparrow}^- and $\mathbf{F}_{\downarrow}^+$ $\left[(\Delta E_E)_{\mathbf{F}_{\uparrow}^- \bowtie \mathbf{F}_{\downarrow}^+}^{\mathbf{F}_{\uparrow}^- - \mathbf{F}_{\downarrow}^+} \text{ and } (\Delta E_G)_{\mathbf{F}_{\uparrow}^- \bowtie \mathbf{F}_{\downarrow}^+}^{\mathbf{F}_{\uparrow}^- - \mathbf{F}_{\downarrow}^+} \right]$ of pairs $[\mathbf{F}_{\uparrow}^- \bowtie \mathbf{F}_{\downarrow}^+]$, correspondingly:

$$\mathbf{d} \ln t = -\mathbf{d} \ln (\Delta E_{\mathbf{F}_{\uparrow}^- \bowtie \mathbf{F}_{\downarrow}^+}) = -\mathbf{d} \ln \left[(\Delta E_E)_{\mathbf{F}_{\uparrow}^- \bowtie \mathbf{F}_{\downarrow}^+}^{\mathbf{F}_{\uparrow}^- - \mathbf{F}_{\downarrow}^+} + (\Delta E_G)_{\mathbf{F}_{\uparrow}^- \bowtie \mathbf{F}_{\downarrow}^+}^{\mathbf{F}_{\uparrow}^- - \mathbf{F}_{\downarrow}^+} \right] \quad 7.6$$

$$\text{or : } \frac{\delta t}{t} = -\frac{\delta \left[(\Delta E_E)_{\mathbf{F}_{\uparrow}^- \bowtie \mathbf{F}_{\downarrow}^+}^{\mathbf{F}_{\uparrow}^- - \mathbf{F}_{\downarrow}^+} + (\Delta E_G)_{\mathbf{F}_{\uparrow}^- \bowtie \mathbf{F}_{\downarrow}^+}^{\mathbf{F}_{\uparrow}^- - \mathbf{F}_{\downarrow}^+} \right]}{\left[(\Delta E_E)_{\mathbf{F}_{\uparrow}^- \bowtie \mathbf{F}_{\downarrow}^+}^{\mathbf{F}_{\uparrow}^- - \mathbf{F}_{\downarrow}^+} + (\Delta E_G)_{\mathbf{F}_{\uparrow}^- \bowtie \mathbf{F}_{\downarrow}^+}^{\mathbf{F}_{\uparrow}^- - \mathbf{F}_{\downarrow}^+} \right]} \quad 7.6a$$

Variation of Bivacuum symmetry shift by physical fields (EM or gravitational) may influence the value and even sign of pace of time of virtual replicas, i.e. their future or past.

Superconsciousness (SC), as a result of superposition of all Virtual Replicas of the Universe, could be considered, as a Quantum Supercomputer, acting as a self-organizing and evolving hierarchical hologram-like system in both time directions (future and past). The stimulating signals for such processing of SC, as a superposition of huge number of the Galactic Virtual Replicas $[GVR(t)]$ represent the perturbations of $GVR(t)$, induced, in-turn, by changes in discreet individual virtual replicas of nonliving and living organisms, composing $GVR(t)$.

The time-dependent superposition of individual virtual replicas of inorganic matter and living organisms (if any) of each star (solar) system forms the Star system Virtual Replica (SVR) and a Star system consciousness (SSC). In turn, superposition of all stars systems virtual replica SVR and SSC, as a function (F) of SVR, of the Galactic can be responsible for formation of Galactical Superconsciousness (GSC):

$$\text{Galactical Superconsciousness (t)} = \mathbf{F}(\mathbf{GVR}(t)) = \sum \text{SSC}(t) \quad 7.7$$

$$\text{where: } \text{SSC}(t) = \mathbf{F}(\text{SVR}) = \mathbf{F} \left\{ \sum [\text{VR}_M(t) \bowtie \text{VR}_L(t)] \right\}$$

where: $\text{VR}_M(t)$ and $\text{VR}_L(t)$ are the selected/individual virtual replicas of material objects

and living organisms, in the case of their existence in given star system.

Due to virtuality of superposition of $[VR_{M,L} = VR_M(t) \approx VR_L(t)]$ and $SVR(t)$, they by definition do not follow the laws of special theory of relativity and, consequently, the causality principle.

As a result of ability of star virtual replicas (SVR) to evolution/self-organization in Bivacuum, as in active medium in each selected current moment of time $t = t_C$, we have an infinitive number of discreet projections of current SVR (most stable in this moment) and states of star systems consciousness (SSC) on the Future time (t_F) :

$$\mathbf{SSC}_{Future} = \mathbf{F} \left\{ \sum_{\infty} SVR_F(t_F) \right\} = \mathbf{F} \left\{ \sum_{\infty} \sum_{\infty} VR_F(t_F) \right\} \quad 7.8$$

In similar way we have the infinitive number of metastable 'memorized' Virtual replicas $VR_P(t)$ of the Past time (t_P) :

$$\mathbf{SSC}_{Past} = \mathbf{F} \left\{ \sum_{\infty} SVR_{Past}(t_P) \right\} = \mathbf{F} \left\{ \sum_{\infty} \sum_{\infty} VR_{Past}(t_P) \right\} \quad 7.9$$

Each selected $\mathbf{SSC}(t_F, t_P)$ of the future and past time is dependent on the virtual future and past time quantization with current time (t_C), as a reference point:

$$t_F = t_C + \sum_{q=1}^{q=\infty} \Delta t_q \quad 7.10$$

$$t_P = t_C - \sum_{q=1}^{q=\infty} \Delta t_q \quad 7.11$$

where Δt_q is a quantum of time (minimum time interval) separating formation of stable states of SVR_q and SVR_{q+1} , representing system of standing virtual waves, forming instant Star system virtual replicas.

The quanta of information is emitted or absorbed in the process of quantum jump between SVR_{q+1} and SVR_q by analogy with emission/absorption of quanta of energy (photons), as a result of quantum transitions between different electronic states of atoms and molecules.

In accordance to our theory (see eqs. 5.48; 5.48a), pace of time in $SVR(t_F, t_P)$ is determined by pace of virtual external translational longitudinal and transverse kinetic energy of BVF^\uparrow and BVF^\downarrow , related directly to virtual Electromagnetic and Gravitational potentials $[EM(t_F, t_P)$ and $G(t_F, t_P)]$.

We consider Star system Supeconsciousness (SSC), as a virtual quantum supercomputer, enable to extrapolate the most probable future SVR_F from the 'memorized' past SVR_P , taking into account all details of current SVR_C .

Clairvoyance or anticipation is a result of ability of gifted psychic [Sender] to 'search', using specific 'key words-address' at first stage - the right $SVR_F(t)$ at certain time and then select from this future Star system virtual replica the right individual $VR_F(t)$. This complex process includes very 'tuned' interaction of the astral and mental bodies (distant VR) and ether (local VR) bodies of [Sender] with $\sum_{\infty} SVR_F(t)$. Similar mechanism works, in accordance to our approach, in extra-perception by Sender - psychic of the past of some individual $VR_P(t)$, as a selected component of $\sum_{\infty} SVR_P(t)$.

The experimental data are obtained, that the conscious measurement of some event by one brain tends to reduce the element of surprise for other brains, observing the same event.

These most interesting data can be explained in framework of our UM model as a two stage process, involving hierarchy of virtual replicas.

The 1st stage is represented by following scheme of modification of Star system virtual replica (SVR), including and depending on the Earth virtual replica (EVR) and Sun system Superconsciousness (SSC): $[SVR = f(EVR) \rightarrow SVR^*$ and $SSC \rightarrow SSC^*]$, induced by change of mental and internal-ether physical VR of human brain and nerve system, as a result of 'leaning - getting the same new information' by one or few human beings (j) via external astral and mental VR:

$$\begin{aligned} \sum_j [\mathbf{VR}_{mental} + \mathbf{VR}_{ether}] + \mathbf{Info} &\rightarrow \sum_j [\mathbf{VR}_{mental}^* + \mathbf{VR}_{ether}^*] \rightarrow \\ &\rightarrow \sum_j \mathbf{VR}_{astral}^* \rightarrow [\mathbf{EVR}^* \bowtie \mathbf{SVR}^*] \rightarrow \mathbf{SSC}^* \end{aligned} \quad 7.12$$

The 2nd stage is related with action of modified Solar system Superconsciousness (SSC^*) and the Earth virtual replica (EVR) on the individuals human consciousness via their external astral (VR_{astral}), mental (VR_{mental}) and corresponding internal - ether (VR_{ether}) virtual replicas of another (k) persons, accompanied by transmission of Information:

$$[\mathbf{SSC}^* \bowtie \mathbf{EVR}^*] \rightarrow \sum_k^{Info} [\mathbf{VR}_{astral} + \mathbf{Info}] \rightarrow \sum_k \mathbf{VR}_{astral}^* \rightarrow \sum_k [\mathbf{VR}_{mental}^* + \mathbf{VR}_{ether}^*] \quad 7.13$$

The mental and ether virtual replicas: \mathbf{VR}_{mental} and \mathbf{VR}_{ether} are the external and internal reflections of quantum neurodynamics process in brain and the nerve system, correspondingly. Each elementary act of consciousness, as a transition between discrete neuron's ensemble states, should be accompanied by corresponding transition between mental and ether VR, following by emission or absorption of quantum of information (*infoquant* – IQ) quantum states:

$$[\mathbf{VR}_{mental} + \mathbf{VR}_{ether}]_j - [\mathbf{VR}_{mental} + \mathbf{VR}_{ether}]_k = \mathbf{IQ} \quad 7.14$$

We may postulate, that IQ is a minimum information ($IQ = \min Info$), which can irreversibly change the mental and astral virtual replica: $[(\mathbf{VR}_{mental} \bowtie \mathbf{VR}_{astral}) + \mathbf{IQ}] \rightarrow \mathbf{VR}_{astral}^*$ and perturbation of the Earth virtual replica (\mathbf{EVR}^*), then Solar virtual replica (\mathbf{SVR}^*) and finally variation of Superconsciousness (\mathbf{SC}^*):

$$[\mathbf{EVR} \bowtie \mathbf{SVR} \bowtie \mathbf{SC}] \xrightarrow{IQ} [\mathbf{EVR} \bowtie \mathbf{SVR}^* \bowtie \mathbf{SC}^*] \quad 7.15$$

If such a model is right, then we share with mankind all well formulated by individuals IDEAS.

The IDEA, as a coherent and stable superposition of IQ : $\mathbf{IDEA} = \sum_k c_k IQ_k$ may influence on the Earth and Solar virtual replicas (EVR and SVR), then Superconsciousness and then, via feedback reaction it affect the individual consciousness of all the rest of human beings.

Our ideas of the Universe, solar and the Earth Virtual Replicas, their interrelation with duality of matter and corresponding levels of Superconsciousness, have some common features with One Mind Model of Mark Germaine (2002)³⁹ and Henry Stapp⁴⁰ hypothesis of interrelation between collapsing of superimposed mental states and actual world.

8 Experimental evidence in proof of Unified Model (UM)

The formulae (5.33 and 5.34) for electromagnetic and gravitational potentials in general case (not just for Golden mean conditions) can be presented as:

$$\mathbf{E}_{\mathbf{E}}^n(F_{\uparrow}^{\pm})_{[C]}^i = \alpha[m_C^+ \mathbf{v}_{res}^2]^i = \alpha \left(\frac{\mathbf{p}^2}{m_C^+} \right)^i \quad 8.1$$

$$\mathbf{E}_{\mathbf{G}}^n(F_{\uparrow}^{\pm})_{[C]}^i = \beta[m_C^+ \mathbf{v}_{res}^2]^i = \beta \left(\frac{\mathbf{p}^2}{m_C^+} \right)^i \quad 8.1a$$

where the momentum of elementary particle: $\mathbf{p} = m_C^+ \mathbf{v}_{res}$; the resulting external velocity squared (see 5.26a):

$$\mathbf{v}_{res}^2 = c^2 \left[1 - \left| \frac{m_C^-}{m_C^+} \right| \right] \quad 8.2$$

It follows from our expressions, that the charged particle, accelerating permanently (like in cyclotron or synchrotron) or alternatively, like in ondulator, should be a source of photons and gravitational waves:

$$\hbar\omega_p = [\mathbf{E}_{\mathbf{E}}^n(F_{\uparrow}^{\pm})_{[C]}^i]_{t+\Delta t} - [\mathbf{E}_{\mathbf{E}}^n(F_{\uparrow}^{\pm})_{[C]}^i]_t = \alpha[(m_C^+ \mathbf{v}_{res}^2)_{t+\Delta t} - (m_C^+ \mathbf{v}_{res}^2)_t] \quad 8.3$$

$$\hbar\omega_G = [\mathbf{E}_{\mathbf{G}}^n(F_{\uparrow}^{\pm})_{[C]}^i]_{t+\Delta t} - [\mathbf{E}_{\mathbf{G}}^n(F_{\uparrow}^{\pm})_{[C]}^i]_t = \beta[(m_C^+ \mathbf{v}_{res}^2)_{t+\Delta t} - (m_C^+ \mathbf{v}_{res}^2)_t] \quad 8.3a$$

There are huge number of experimental data, confirming this consequence of presented theory for electromagnetic radiation. The gravitational radiation in similar conditions is also predictable by our Unified Model (UM).

For the case of cyclotron radiation, the photons are result of transition between quantum Landau levels:

$$E_n = \hbar\omega_p = (n + 1/2)\hbar\omega_c \quad n = 1, 2, 3, \dots \quad 8.4$$

where the cyclotron frequency of the electrons rotation in plane, normal to magnetic field \mathbf{H} is

$$\omega_c = \frac{e\mathbf{H}}{m_C^+ c} \quad 8.5$$

The other consequence of UM is that this kinds of radiation should be strongly asymmetric, coinciding mostly with direction of particle propagation in space. It is also well supported especially by experimental analysis of synchrotron and ondulator radiation.

Most of energy, emitted by relativist particle is located in direction, close to its instant velocity ($v = v_{ext} \rightarrow c$) in narrow angles range, determined by semiempirical expression (Ginsburg, 1987):

$$\Delta\theta \simeq [1 - (v/c)^2]^{1/2} = \frac{m_0 c^2}{E} \ll 1 \quad 8.6$$

where: E is a total relativist energy of the charged particle.

Our theory leads to same result. Formula (5.20) for relativist condition ($v \rightarrow c$), taking into account (5.18a), can be presented as:

$$[1 - (v/c)^2]^{1/2} = \left| \frac{m_C^-}{m_C^+} \right|^{1/2} = \frac{m_0 c^2}{m_C^+ c^2} = \left(\frac{S^+}{S^-} \right)^{1/2} \ll 1 \quad 8.7$$

where S^+ and S^- are the cross sections of the actual vortex and complementary rotor of sub-elementary particles (see 5.10). Their ratio determines the angle range of radiation of accelerating particle.

As far, in accordance to our approach, the actual energy of particle is $E = m_C^+ c^2$, we can see that 8.6 coincides with 8.7.

In some special conditions, the ondulator radiation is highly monochromatic and polarized.

Synchrotron radiation also is polarized. The electric vector of radiated photons is in the same plane, as direction of acceleration of particles. As far the direction of acceleration of charged particle in magnetic field change all the time, the photons have the elliptic polarization.

Our notion of Bivacuum (B), as a quantum liquid, composed from sub-quantum particles and their corrective excitations [rotors + antirotors], representing symmetric (primordial B) or quasisymmetric (secondary B) mass - dipoles, electric charge - dipoles and magnetic charge - dipoles, is in accordance with experimental behavior of vacuum in strong electromagnetic field, as anisotropic medium with double refractive properties. For example, the refraction index of vacuum is dependent on polarization of photons in strong magnetic field, shifting spin equilibrium: $[BVF^\uparrow \rightleftharpoons BVF^\downarrow]$ normal or in-line with magnetic field tension and making ϵ_0 of Bivacuum anisotropic. Such effects can be analyzed also in terms of nonlinear properties of vacuum (Ginsburg, 1987).

The reduced radius of cumulative virtual cloud (CVC), representing [W] phase of each sub-elementary particle and antiparticle, determines the radius of virtual wave-guide (VirWG), formed by virtual spin waves (VirSW). For the other hand, VirWG is responsible, in accordance to our hypothesis, for channeling the virtual and real photons, emitted by accelerated electrons or positrons. The experimental results, pointing to decreasing the radiation angle of photons ($\Delta\theta$) is in total accordance with this hypothesis.

*Our Unified Model is the first physical theory, being able to explain the fundamental quantum roots of Golden mean (GM) in Nature (see section 5.6 of this paper and <http://arXiv.org/abs/physics/0207027>). It appears to be a result of "Hidden Harmony", when the **external and internal** group and phase velocities of sub-elementary particles are equal:*

$$\begin{aligned} \mathbf{v} &= \mathbf{v}_{gr}^{in} \\ \mathbf{v}_{ph}^{ext} &= \mathbf{v}_{ph}^{in} \end{aligned} \quad 8.8$$

This important consequence of our approach also can be considered as a strong evidence in proof of its validity.

The Unified Model allows to calculate the *magnetic moment of the electron* from analytical formulae with high accuracy, comparable with perturbation approach of Quantum electrodynamics (Kaivarainen, <http://arXiv.org/abs/physics/0207027>). This also points to correctness of our theory.

8.1 Experimental confirmation of our theory of Bivacuum-mediated Mind-Matter Interaction

It was shown in Russia, that in microcalorimeters, EM fields screened and temperature shielded, the distant (from few meters to 3 thousand kilometers) influence of psychic - sender displays, as a jump-way signal changes²⁵ (Parhomov, 2002). These changes correspond to decreasing of temperature of the melting ice, surrounding the detector. The authors have not any explanation of such results. Our theory of Bivacuum mediated mind - matter interaction explain them, as a consequence of stabilization of thermal oscillations of water molecules in ice, due to increasing of H-bonds strength and Van-der-Waals interaction between molecules. In turn, such stabilization is a consequence of elevation of Coulomb interactions and hydrogen bonds between **H₂O** dipoles, induced by decreasing of Bivacuum permittivity (ϵ_0) in the Virtual channel between Sender and Target (microcalorimeter).

The good psychic was able to influence microcalorimeters signals from the neighboring room, as well, as from other city. It is important to note, that very remote interaction (thousands of kilometers) was registered well, while in the next room it was not at all, until the psychic was informed about this close location of device. This points to highly anisotropic properties of VR, generated by psychic. The better name for such asymmetric VR will be virtual channel (VirCh). *The Psi-channel is a private case of Bivacuum Virtual channel (VirCh), working in the cases of mind-matter and mind-mind interaction (telepathy), distant healing, remote vision, etc.*

In other experiments, the changes of low and infra-low frequencies 'flicker noise' or (1/f) noise in electronic devices, like photo-resistors, photocathodes, where semiconductors are used in semi-crystalline state, like in metal-oxide-semiconductor (MOS transistors), under the psychic influence also has been revealed. The essence of flicker noise, in contrast to high-frequency 'white noise', generated by thermal fluctuations, is obscure. We suppose, that flicker noise may be generated by fluctuations of Bivacuum permittivity (ϵ_0) and permeability (μ_0). These fluctuations, related to Bivacuum symmetry oscillations (BvSO), virtual spin waves (VirSW) and virtual pressure waves (VPW $^\pm$) can be coherent in big macroscopic domains of space with dimensions, determined by those of Virtual Bose condensate (VirBC), formed by Bivacuum fermions (eq. 5.3a).

The influence of 'Sender - psychic' on MOS device, conducted by Virtual channel, led sometimes to *tens of times* increase or decrease in the amplitude of fluctuations. It is important to note, that these changes in amplitude continued even after termination of the Sender [S] activity with *relaxation time (memory)* about 5-10 min²⁵ (Parhomov, 2002). This can be explained by the long life-time relaxation of perturbed by [S] virtual replica of target/receiver [R].

The revealed perturbation of character of flicker noise of electronic devices can be relevant to influence of intention of 'operator' on random number generator (RNG).

8.2 Imitation of Mind-Matter interaction by macroscopic flicker noise or macroscopic fluctuations

It was shown also by the same group (Parkhomov, 2002), that the low frequency fluctuations of MOS device and photoresistors increased sharply even without psychic action with synodic lunar cycle (29.5 days). This rhythm corresponds to that of gravitational field variation, caused by change of the relative position of the Sun, Moon and Earth. These variations are very small - about one/ten-millionth of gravitational field tension on the surface of the Earth. However, the existence of fractional periods of lunar cycle: 3/2; 3/4; 2/3; 1/3; 1/4 also was revealed and confirmed during more than 10 years of recordings of flicker noise. The periods, like 3/2; 3/4; 2/3 are *commensurable* with fundamental harmonics: 1/2; 1/3; 2/3 of lunar cycle. The *commensurability* is characteristic for the orbital and rotational motions. Parkhomov put forward the hypothesis, that in the system [Earth-Moon-Sun] there are some invisible objects, weakly interacting with matter and performing the orbital motion. Our Unified Model (UM) suggest the following explanation: the contribution to external Virtual Replica of system [Earth-Moon-Sun], related to the Earth rotation (virtual spin waves: VirSW) could be modulated by the magnetic and gravitational interactions in this system. The frequencies of this modulation corresponds to 3/2; 3/4; 2/3; 1/3; 1/4 of lunar synodic cycle. Each act of modulation/perturbation of VR of the Earth (external and internal) is accompanied by corresponding change of [$\mathbf{BVF}^\uparrow \rightleftharpoons \mathbf{BVF}^\downarrow$] equilibrium, related to Bivacuum polarization and change of ϵ_0 and μ_0 of Bivacuum.

The condensed matter, sensitive to such perturbations, like photo-resistors and MOS, registered such global VR perturbation. It may be anticipated that mind-matter and mind-mind interactions would be different in the maximums and minimums of these effects.

It looks, that Virtual Replica in Bivacuum, generated by psychic or by the [Earth-Moon-Sun] dynamic system, can be imitated and modulated by some asymmetric inorganic constructions, like pyramids, rings, etc. In work of Adamenko, Levchook (1994)²⁷, Narimanov (2001)³⁴ and Miakin (2002)³⁵ such effects has been demonstrated on examples of following test-systems, placed inside pyramids: the cultures of microbes (dynamic behavior), water (pH, O₂ concentration), polymers solution (optical density), benzene acid (UV absorption).

The superposition of internal Virtual Replicas of the pyramids should be much more asymmetric/dynamic, than VR inside the cube - shape cavity, representing a system of standing virtual waves. The effects of different virtual replicas on test systems, like water and aqueous solutions, generated by such two cavities, are anticipated to be different also. This consequence of our model can be verified experimentally.

The sharpening of the razor blades after their keeping inside pyramids, revealed experimentally, may be a consequence of increasing probability of virtual charged particles + antiparticles pairs origination in the internal VR of pyramid due to its asymmetry (i.e. Bivacuum polarization). Consequently, the dielectric permittivity (ϵ_0) of Bivacuum increases. In turn, this induces the decreasing of ion-ion, ion-dipole and dipole-dipole interactions in condensed matter (blade) inside the pyramid. As a result, the small structural irregularities with bigger relative interface, interacting with perturbed Bivacuum, on the top of blade, responsible for its sharpness, became unstable and gradually destroyed under the effect of thermal fluctuations. The blade becomes sharper.

The dependence of internal VR of cavity on its shape, leading from our theory, is confirmed by the different Lamb shifts in atomic spectra of samples in cavities of different shape. It is known, that the Lamb shift is determined by screening of the electrons and nuclears charges by the charged virtual vacuum particles and antiparticles. In our model such a particles/antiparticles may be represented by $BVF^\uparrow = [V^+ \uparrow\uparrow V^-]$ and $BVF^\downarrow = [V^+ \downarrow\downarrow V^-]$, acquiring nonzero charge, as a result of their vortex and antivortex small asymmetry.

These effects confirms, that each physical object has its internal and external virtual replica (VR), depending on the shape of this object and its exchange interaction with Bivacuum. The so-called regular *geopathogenic zones* or '*Hartman network*' can be a result of some nonregularities in density distribution in volume of the Earth, providing corresponding internal Earth Virtual Replica (EVR) in form of standing virtual pressure waves (VPW $^\pm$) network.

8.3 Experimental data, pointing that dissipation processes change the properties of Virtual replica (VR) of matter - [Sender] and interaction between [Sender] and [Receiver]

The highly important experimental results, obtained by group of Korotaev in Moscow, point to existence of unknown - nonelectromagnetic mechanism of all-penetrating physical interaction (Korotaev, et. al., 1999; 2000)²⁸⁻³⁰.

These results also can be considered, as a consequence of existence in Bivacuum virtual replicas (VR) of matter, virtual pressure waves (VPW $^\pm$) channels, transmitting the energy:

$$\mathbf{VPW}_S^+ \approx \mathbf{VPW}_R^+ \quad (\text{standing waves in realm of positive energy}) \quad 8.8a$$

$$\mathbf{VPW}_S^- \approx \mathbf{VPW}_R^- \quad (\text{standing waves in realm of negative energy})$$

and virtual wave-guides, transmitting spin (phase) and virtual photons:

$$\mathbf{VirWG}_S^\circ \approx \mathbf{VirWG}_R^\circ \quad (\text{spin-spin exchange attraction}) \quad 8.8b$$

$$\text{or : } \mathbf{VirWG}_S^\circ \approx \mathbf{VirWG}_R^\circ \quad (\text{Pauli spin-spin repulsion})$$

between sender [S] and receiver [R], depending on the matter [S] phase state (solid, liquid or gas).

One set of Korotaev's group experiments was related to study of artificial dissipation process of [S] on properties of [R]. In the case of artificial sender [S] of virtual signals - open vessel with 2 liters of water, the dissipation processes (boiling of water) - changes the Virtual Replica of water (VR_{water}). As a result, the Bivacuum Virtual Channels (8.8a and 8.8b) variation displays themselves in change of properties of special electronic receiver [R].

This receiver [R] represents a pair of detectors, isolated very well on the external electric and magnetic fields, precisely thermostated, designed to measure the difference of electric potentials between these detectors, dependent on external dissipative process. Each of detectors: U_1 and U_2 , consists of couple of isolated electrodes, placed in germetized glass vessel filled with electrolyte. The distance from the [S] to U_1 was only 0.5 m and from the same [S] to U_2 eight times bigger: 4 m. The electric scheme allows to evaluate the differences of potentials: $\Delta U_{1,2} = (U_1 - U_2)$ under the permanent control of temperature difference $\Delta T_{1,2} = (T_1 - T_2)$ between two detectors of [R] device.

The action of the receiver [R] device is based on the following interrelation between entropy

of double electric layer (ΔS_d) temperature (T) and $\Delta U_{1,2}$ (Korotaev, Sorokin, Serdyuk, 2000)³⁰ :

$$\Delta S_d = -\frac{1}{\sqrt{6}} \frac{|q|}{kTg} \Delta U_{1,2} \quad 8.9$$

where: q is a charge of ions of liquid phase of double layer; k is a Boltzman constant and g is a technical parameter of [R] device.

The effect of temperature change in a course of water in [S] heating was about three order less, than the effect of boiling process itself, displaying in decreasing of $\Delta U_{1,2}$. Qualitatively this effect of boiling, accompanied by the entropy increasing ($\Delta S_d > 0$) in source [S], is in accordance with (8.9).

The time of water heating from the room temperature to boiling point was about 14 min, the time of boiling was about $\Delta t_b \simeq 40 \text{ min}$ till the evaporation of half of water volume ~ 1 liter. After this the heater was switched off. About 2h after this, the value of $\Delta U_{1,2} = (U_1 - U_2)$ was abruptly decreased and then the many hours long relaxation process to the starting level occurs.

It was calculated that the classical effect on $\Delta U_{1,2}$ of very small change of temperature in this process $\Delta T_{1,2} = 0.008 \text{ K}$ is incomparable small as respect to observed effect of $\Delta U_{1,2}$, induced by water boiling. It was shown that the effects of the ice melting and mixing of water with other liquids are smaller, than the boiling effect with bigger entropy increasing.

The important observation is a significant time lag ($\Delta t_I = t_{I,2} - t_{I,1}$) between activation time of [S] - when boiling starts ($t_{I,1}$) and activation time of [R], representing $U_{1,2}$ decreasing ($t_{I,2}$). The second lag is between switching off the boiling ($t_{II,1}$) and restoration (relaxation time, $t_{II,2}$) of the initial $U_{1,2}$ value ($\Delta t_{II} = t_{II,2} - t_{II,1}$).

The second lag period (Δt_{II}) appears to be about 8 times longer, than the first one: $\Delta t_{II}/\Delta t_I \approx 8$.

This means that the dependence of $\Delta U_{1,2}(t)$ is essentially asymmetric. This asymmetry is proportional to the maximum amplitude of boiling effect $|\Delta U_{1,2}^{\max}|$:

$$\Delta t_{II}/\Delta t_I = -3.2 \Delta U_{1,2}^{\max} + 0.39 \quad 8.10$$

Between the total relaxation time of boiling - induced change of $\Delta U_{1,2}$: $\Delta t_{I,II} = \Delta t_I + \Delta t_{II}$ and the time of water boiling itself (Δt_b) the following relation has been established (Korotaev, et al. 2000):

$$\Delta t_{I,II} = \Delta t_I + \Delta t_{II} = \Delta t_b [\exp(-\Delta U_{1,2}^{\max}/E) - 1] = \Delta t_b [\exp \Delta S_d - 1] \quad 8.11$$

where the empirical expression for potential $E = \sqrt{6} kTg/|q|$.

It leads from (8.11) that the total relaxation time of the boiling - induced effect in [R] device ($\Delta t_{I,II} = \Delta t_I + \Delta t_{II}$) is determined by the time of boiling (Δt_b) and entropy change ($\Delta S_d = -\Delta U_{1,2}^{\max}/E$) in the double electric layer of detectors (ΔS_d).

It was demonstrated, that these unusual water-boiling induced retard (Δt_I) reaction of [R]-system and retard relaxation effects after the boiling was stopped (Δt_{II}) are not the consequence of local T-variations, or the external permanent magnetic or EM fields action. The effects obtained can not be explained in the framework of regular physics.

We can suggest the following explanation of this new kind of all-penetrating interaction, based on our theory of Bivacuum and virtual replicas (VR) of matter, changing with the state of matter [Sender]. In accordance to our Hierarchical theory of condensed matter, general for liquids and solids (Kaivarainen, 1989-2001) and Unified Model, such processes, as boiling or melting of water and ice, correspondingly, are accompanied by the change of contribution of molecular mesoscopic Bose condensation (mBC - coherent water clusters) to VR of each of these two phase (liquid and solid). As far, the [C \rightleftharpoons W] pulsations of elementary particles of molecules, composing water coherent clusters should be in-phase, they provide the corresponding amplitude and stability of VR of the solid, liquid and gas phases of matter in Bivacuum.

Before the heating (14 min) and boiling/evaporation (40 min) of water, the differences of

potentials: $\Delta U_{1,2} = (U_1 - U_2)$ between two detectors is determined by superposition of Virtual replicas (VR) of these detectors and all surrounding matter, including that of vessel with 2 liters of water (VR_{water}). Boiling and evaporation of water from 2 liters to 1 liter is accompanied by:

- a) decreasing the influence of VR_{water} on $\Delta U_{1,2} = (U_1 - U_2)$, as a result of gradual evaporation in a course of boiling;
- b) increasing the influence of water vapor VR_{vapor} on $\Delta U_{1,2} = (U_1 - U_2)$;
- c) influence of the intermediate phase [$\text{water} \rightleftharpoons \text{vapor}$] fluctuating virtual replica: $\text{VR}_{\text{water}} \rightleftharpoons \text{VR}_{\text{vapor}}$.

The long time delay between the starting of boiling and reaction of $\Delta U_{1,2}$ of detectors ($\sim 2\text{h}$) on boiling (Δt_I) can be explained by stability of VR_{water} , created by 2 liters of water in vessel between two detectors before starting of its boiling and long time of creation of VR_{vapor} , different from VR_{water} .

The relaxation time (Δt_{II}) to the starting value of $\Delta U_{1,2}$ after switching off the water heating and boiling is about 8 times longer, than the lag (Δt_I) of the effect, induced by boiling. This asymmetry point to stable perturbation of resulting virtual replica of [S + R] in Bivacuum (VR_{res}), induced by boiling and evaporation.

It is obvious, that the vacuum perturbations can not be screened any way, as far vacuum is all space filling medium. For the other hand, the changes of Bivacuum permittivity (ϵ_0) and permeability (μ_0) should be accompanied by the change of Coulomb interaction in the double electric layer of detectors and, consequently, by its entropy. As far, due to different distance of vessel with water [S] from the 1st and 2nd detectors, the VR_{res} perturbations nearby them also are not the same, the experiment show corresponding difference between detectors: $\Delta U_{1,2} = (U_1 - U_2)$. This means, that the perturbation of VR_S by boiling has isotropic spherical symmetry and the orientations of channels 8.8a and 8.8b, generated by VR_S , have the isotropic spatial orientations.

It is interesting to note the *absence of regularity in changes* of such parameters, as the amplitude of $\Delta U_{1,2}$, the both times of delay Δt_I and Δt_{II} , notwithstanding of the permanent laboratory conditions, in a lot of independent experiments (50) during 3 month: August - October.

However we have to point out, that the existence of fractional periods: 3/2; 3/4; 2/3; 1/3; 1/4 of lunar cycle (29,5 days) obviously was not taken into account in Korotaev's team experiments. In accordance to comments, given above to experiments with flicker noise detectors, these fractal periods means variations of the resulting virtual replica (VR_{res}), dependent on the change of $\text{VR}_{\text{Earth+Moon+Sun}}^{\text{Solar System}}$ of dynamic system: [Earth + Moon + Sun], as a part of virtual replica of the whole Solar system ($\text{VR}^{\text{Solar System}}$).

The resulting virtual replica (VR_{res}) in the volume of registration system is a complex superposition of lot of virtual replicas of material objects of different space scales. It can be presented as a function of superposition of number of:

$$\text{VR}_{\text{res}} = \mathbf{F}(\text{VR}_{S+R}; \text{VR}_{\text{Lab}}; \text{VR}_{\text{Building+Environment}}; \text{VR}_{\text{Earth+Moon+Sun}}^{\text{Solar System}}) \quad 8.12$$

where: VR_{S+R} is a combined virtual replica of detectors/receivers [R] (electrodes) and source of Bivacuum perturbation - vessel with boiling water [S]; VR_{Lab} is a complex virtual replica, generated by mass spatial distribution in the laboratory room (i.e. positions of other equipment in room, position of registration system as respect to walls of laboratory room, etc.), geometry of room; $\text{VR}_{\text{Building+Environment}}$ is a contribution of the external as respect to laboratory space the Building and its Environment complex virtual replica.

Consequently, periodical changes of $\text{VR}_{\text{Earth+Moon+Sun}}^{\text{Solar System}}$ in (8.12) may modulate the VR_{res} and, consequently, the amplitude of $\Delta U_{1,2}$ and the both times of delay Δt_I and Δt_{II} in the described above experiments. The circadian - 24h rhythms also can influence on VR_{res} and the results of experiments.

The violation of causality principle, when the consequence precedes the effect, could be a

consequence of ability of Resulting virtual replica: $\mathbf{VR}_{res} = f(t \pm n\Delta t)$ to self-organization in both time directions - future and past during certain time interval $\pm n\Delta t$, corresponding to formation one of the most stable \mathbf{VR}_{res} . Such kind of self-organization can be considered as a result of action of \mathbf{VR}_{res} , as a quantum supercomputer, including extrapolation from current to future states and 'memorizing' the selected time-quantized states (see section 7.5 of this paper).

The feedback reaction between properties of $\mathbf{VR}_{res} = f(t \pm n\Delta t)$ on the properties of registration system $[R] = F(t)$ - can explain the registration by Korotaev's group of the anticipated/advanced reaction on macroscopic geomagnetic and solar dissipative processes. The similar receivers $[R]$, representing a pair of detectors, described above has been used. The registration of difference: $\Delta U_{1,2} = (U_1 - U_2)$ was performed during 366 days and nights from (10.12.1996) till (11.12.1997) with time interval 30 minutes.

The good correlation (coherency) between changes of potentials in form of *flicker noise* of two receivers: $[R_I]$ and $[R_{II}]$, separated from each other to 300 m, was revealed. Our approach explains this important fact, as a consequence of nonlocal properties of virtual replica ($\mathbf{VR}_{Earth+Moon+Sun}^{Solar\ System}$) of the system: [Earth + Moon + Sun], changing coherently in large-scale geophysical processes. In section 8.4 we discuss the possibility of *common physical mechanism of macroscopic flicker noise and macroscopic fluctuations*, revealed in S. Shnoll's experiments.

The receivers do not react on the actual changes of the Earth magnetic field in real-current time, induced by ionospheric variations, related, in turn, with variation of Sun activity. However, two unusual anticipated/advanced and the lag/delay signals of receivers $[R]$ with characteristic time interval about:

$$\Delta T = \pm n\Delta t = 48 \text{ hours at } n = 1$$

as respect to change of the Earth magnetic field and Sun activity, has been revealed. Just this value of lag can mean, that this time interval corresponds to one of the most stable time-dependent resulting virtual replicas $\mathbf{VR}_{res} = f(t \pm n\Delta t)$ in the infinity cycles ($n \rightarrow \infty$) of its self-computing/self-organizing process.

The interpretation of Korotaev, et al., based on possible interaction of dissipative systems and causality mechanics, developed by Kozyrev, do not contradicts our interpretation of perturbation of virtual replica (\mathbf{VR}_S) of condensed matter (sender/source), as a result of 'melting' of coherent molecular clusters - mesoscopic Bose condensates (mBC). However, the macro time-effects explanation, based of dissipation, looks much less clear, than that, based on notion of our resulting \mathbf{VR}_{res} (8.12) with properties of quantum supercomputer, calculating future and past of \mathbf{VR}_{res} current informational and physical state.

*Any dissipative processes in system of sender - source [S] function, like melting, boiling or huge correlated fluctuation, as Sun alternations, are accompanied by this system Virtual replica changes $[VR_S]$. The resulting Virtual replica, like presented by (8.12), also change with $[VR_S]$ and the introduced in our theory **Bivacuum-Mediated Interaction (BMI)** is responsible for corresponding perturbation of Virtual replica of Receiver - detector $[VR_R]$.*

We suppose, that when the frequency of flicker noise of matter, forming [S] and [R] and that of flicker noise of the resulting virtual replica (8.12) - coincide, the resulting probability of signal transmission from [S] and detection by [R], related to the amplitude of signal ($A_{S,R}$) is maximum. The resulting probability ($P_{S,R}$) of two independent events can be presented, as a product of probabilities of these events. We propose, that these probabilities are proportional to the most probable reverse frequencies of flickering noise, coherent in the huge volume of the resulting \mathbf{VR}_{res} (8.12):

$$A_{S,R} \sim P_{S,R}(f_{S,R}) = P_S(f_S) P_R(f_R) \sim (1/f_S) (1/f_R) = 1/f_{S,R}^2 \approx 1/f_{res}^2 \quad 8.13$$

$$\text{at the resonance condition : } f_S = f_R = f_{S,R} = f_{res} \quad 8.13a$$

The expression (8.13), proposed, means, that the ratio of the signal/effect amplitude ($A_{S,R}$) to $1/f_{res}^2$ should be constant:

$$\frac{\mathbf{A}_{S,R}}{\mathbf{1}/\mathbf{f}_{S,R}^2} \simeq \frac{\mathbf{A}_{S,R}}{\mathbf{1}/\mathbf{f}_{res}^2} = const \quad 8.14$$

Korotaev's experiments, described above, related to fluctuations of Sun activity, confirm the validity of relation (8.14). It means that the modulation frequency of geophysical and/or cosmic magnetic fields fluctuations (flicker noise) of virtual wave-guide (VirWG), formed by virtual spin-waves (VirSW - see 8.8b) and virtual pressure waves (VPW $^{\pm}$ - see 8.8a) between Sender (VR $_S$) and Receiver (VR $_R$), should be the same.

8.4 Possible theoretical background of S. Shnoll "Macroscopic fluctuations"

It is quite possible, that macroscopic flicker noise, so important in experiments described above, has the same physical nature as "Macroscopic fluctuations", discovered by Simon Shnoll³⁶ and his team on very different test-systems and proved during of about 50 years systematic investigations (1954-2003). 'Macroscopic' means that fluctuations are coherent at least in the volume of test systems.

The following systems where under study:

- biochemical (activity of enzymes, cells, etc.);
- chemical (Belousov-Zabotinsky oscillatory reaction parameters, water properties, etc.);
- physical (radioactive decay, etc.).

Each of these system at the same place and time of 24 hours displayed the identical character of fluctuations in form of histograms, independently of big difference in activation energy of corresponding processes.

It was revealed, that even at very remote places of the Earth surface - from hundreds to thousands kilometers, the histograms have very similar shapes, if the fluctuations in test-systems where measured at the same *local* time. This means that test- system in the same position/distance as respect to Sun and Moon displays similar fluctuations.

One more important observation was done by this group. During the time of Sun eclipse, i.e. 'screening' of Sun by Moon, the histograms over all the Earth surface, obtained by any test systems were similar by shape and this shape was much more 'simple' than in non eclipse time.

The authors of this huge by volume and time-span work did not presented yet theoretical explanations of their important discoveries, as far it is obviously out of existing scientific paradigms.

Our Unified Model UM) may present the following explanation of macroscopic fluctuation phenomenon.

It could be a result of fluctuations of Sun's Virtual Replica (VR $_S$), correlated with Sun entropy fluctuations, modulated by relative positions of the Earth, Moon, other planets and their Virtual Replicas (VR $_{planets}$).

In such a scenario of interaction between *Sender [S] - Sun* and *receiver [R] - test system* the beats between virtual pressure waves (VPW $^{\pm}$) and interference between virtual spin waves (VirSW) of Sender and Receiver occur:

$$VPW_S^{\pm} \simeq VPW_R^{\pm} \quad 8.15$$

$$VirSW_S \simeq VirSW_R \quad 8.15a$$

As was mentioned earlier, the interaction (8.15) may be accompanied by fluctuations of superfluous energy of asymmetric Bivacuum, different on the surface of Sun and Earth. For the other hand VirSW (8.15) may form virtual wave-guides *VirWG*, able to transport virtual and real photons from [S] to [R].

The VirSW may also perturb the Bivacuum properties due to realization of virtual Pauli repulsion between Bivacuum fermions ($\mathbf{BVF}^{\cup} < \Rightarrow \mathbf{BVF}^{\cup}$) with similar spins and the exchange attraction between \mathbf{BVF} with opposite spins ($\mathbf{BVF}^{\cup} \bowtie \mathbf{BVF}^{\cup}$). *These complex phenomena and competition between them make the influence of Bivacuum on the test-systems very unstable with properties of flicker noise or macroscopic fluctuations (MF).*

The independence of character of MF of any processes on different physical nature of test-systems and corresponding histograms, we may explain by fundamental background of test-systems perturbation by [Sender], like frequency, phase and amplitude of coherent $[C \rightleftharpoons W]$ pulsation of elementary particles (electrons, nucleons), composing any kind of test systems [Receiver].

The phenomenon of MF looks to be a result of macroscopic quantum entanglement between modulated by the influence of planets Sun's huge number of elementary particles in coherent state of Bose condensation (BC) and coherent elementary particles of the test-systems in state of mesoscopic Bose condensation (mBC).

We suppose that even very high-temperature BC (and superconductivity) is possible in the internal regions of Sun and other Stars, as far it is compensated by the huge pressure. Correlated fluctuations of dimensions of these internal Solar BC domains, related directly to the amplitude of coherent $[C \rightleftharpoons W]$ pulsation of elementary particles, composing these domains, could be a source of macroscopic fluctuations.

8.5 The life-times of Virtual Replicas (phantom effects)

Very interesting experimental results were obtained by Tiller, Dibble and Kohane (2001)³¹ with *Intention Imprinted Electronic Device (IIED)* and aqueous solutions. These results can be considered as a confirmation of introduced in our work *Bivacuum-Mediated Interaction (BMI)* between Sender/Source [S] of Bivacuum perturbation (IIED) and Receiver/Target [R] - water and important role of virtual replicas: VR_S and VR_R formation in this new fundamental interaction. The intention imprintment of device has been realized by gifted psychic.

The following data are in-line with proposed mechanism of Bivacuum-Mediated Interaction between Sender/Source [S] of Bivacuum perturbation (IIED) and Receiver/Target [R]:

- the induced oscillation of pH and temperature (T) of the aqueous solutions $[R_{IIED}]$ under the influence of activated IIED with fundamental period of tens of minutes;
- interaction between the intention imprinted solution $[R_{IIED}]$ and other remote vessels (the distance from $[R_{IIED}]$: 30 to 270 meters), containing water: $[R_1]$, $[R_2]$, $[R_3]$ where accompanied by correlated with $[R_{IIED}]$ oscillations of pH and T of solution and the air outside the vessels. The amplitude of these unusual T oscillations was about 2-3 C and easily registered.

The effects, induced by *Intention Imprinted Electronic Device (IIED)*, were the same inside and outside of the Faraday cage, screening the EM fields. Our analysis of presented by Tiller, Dibble and Kohane³¹ Fourier transformed amplitude spectra of the air temperature oscillations with fundamental period of 46.5 min and five harmonics as well as similar analysis of some other spectra confirm the validity of relation (6.41) and related mechanism proposed.

In one set of experiments the weak interaction between the imprinted by intention vessel with water solution and another one, with distance between them about 15 km, was revealed.

All these results can be explained by the *coherent flicker noise* of Bivacuum VR_{res} around the vessels of [S] and [R] and their VR_S and VR_R , modulated by VR_{IIED} , i.e. by Bivacuum Mediated Interaction (BMI).

The longer the same experimental system, including the Faraday cage, where exposed to activated device IIED (few month sometime), the bigger were the effects of interaction: amplitude and correlation between phase of pH and T oscillations of Sender and Receiver aqueous solutions. This means that formation of stable VR_S of Sender, which determines the degree of perturbation of VR_{res} and, consequently, VR_R needs a long time.

The long relaxation time (phantom effect) of perturbation of virtual replica of receiver [R]/target (about 30 min), exerted by psychic, separated by distance from few meters to few kilometers, after the Psi-channel and active Bivacuum mediated interaction was switched off, was revealed also in experiments with Gas-Discharge-Detector (GDD - Korotkov, 2002)³³ and micro-teslameter (Dulnev, 2002)²⁶.

Similar 'phantom' effects were revealed in a system of interacting 'charged' by intention

vessel of water and few other distant vessels with aqueous solutions, surrounding the 'charged' vessel (Tiller, Dibble and Kohane, 2001)³¹. After replacing the 'charged' vessel far out of system, the 'memory' of its presence remains for a long time. The presence and orientation of large quartz crystal strongly affected the amplitude of 'phantom' effect.

In all experiment, described above, screening of the target [R] from electromagnetic fields by Faraday's cage did not influence on the distant interaction between [S] and [R] and the 'phantom' - the perturbation of resulting VR_{res} effect around the target.

8.6 The Superfluous Energy of Bivacuum and the Ways of its Regulation

The Superfluous, uncompensated Energy of Bivacuum is a result of following phenomena:

a) the Bivacuum mass, electric and magnetic dipoles, named Bivacuum fermions ($BVF_{\pm}^{\uparrow} \equiv [V^{+}\uparrow\uparrow V^{-}]$ and $BVF_{\pm}^{\downarrow} \equiv [V^{+}\downarrow\downarrow V^{-}]$ symmetry shift (positive or negative), when the properties of rotors (V^{+}) and antirotors (V^{-}) becomes non equal:

$$\Delta m_C = m_{BVF_{\pm}} = |m_C^{\uparrow}| - |m_C^{\downarrow}| > 0 \quad 8.16$$

$$\Delta m_C = m_{BVF_{\pm}} = |m_C^{\uparrow}| - |m_C^{\downarrow}| < 0 \quad 8.16a$$

and

$$\Delta e = e_{BVF_{\pm}} = |e_{+}| - |e_{-}| > 0 \quad 8.17$$

$$\Delta e = e_{BVF_{\pm}} = |e_{+}| - |e_{-}| < 0 \quad 8.17a$$

The (8.16-8.17a) conditions mean that Bivacuum fermions (dipoles) acquire the nonzero mass and charge.

It is a consequence that BVF^{\uparrow} gain nonzero transversal translational velocity ($v_{ext} = v > 0$) (see 5.22c) under the influence of corresponding momentums, generating by cumulative effect of huge number of unpaired sub-elementary particles of the Earth, i.e. its gravitational field (see 5.28-5.28b).

The nonzero charge mean, that BVF_{\pm}^{\uparrow} can be polarized in sufficiently strong electric field, changing the macroscopically averaged Bivacuum symmetry, responsible for electromagnetic and gravitational fields. These symmetry shifts in BVF are induced by gravitational potential of the Earth. In rotating cylinders or disks corresponding shifts are due to centripetal acceleration and may be regulated by velocity of rotation. However, the rotation of mass needs the consuming of external energy itself;

b) the consequence of symmetry shifts (8.16 and 8.17a) is the increasing the excessive virtual pressure (ΔVP^{\pm}), defined by difference of energy of positive and negative virtual clouds (VC^{+} and VC^{-}), activated the virtual pressure waves: VPW^{+} and VPW^{-} , as a result of quantum transitions of virtual Cooper pairs $[BVF_{\pm}^{\uparrow} \bowtie BVF_{\pm}^{\downarrow}]^{j-k}$ between sub-levels [k and j] (see eqs. 5.1-5.3):

$$\Delta VP^{\pm} = [VP^{+} - VP^{-}]^{j-k} \sim (VC^{+} - VC^{-})^{j-k} \sim [VPW^{+} - VPW^{-}]^{j-k} \sim \Delta m_C c^2 \quad 8.18$$

b) shifting the dynamic equilibrium $BVF^{\uparrow} \rightleftharpoons BVF^{\downarrow}$ to the left or to the right, changing the attractive spin-spin exchange interaction and Bivacuum 'contraction' or repulsive interaction between BVF of similar spins due to Pauli principle action, leading to Bivacuum 'expansion';

c) increasing the kinetic energy (acceleration) of the charged particles, as far it is accompanied by radiation of photons and gravitational waves by unpaired sub-elementary particles of triplets $\langle [F_{\uparrow}^{-} \bowtie F_{\downarrow}^{+}] + F_{\uparrow}^{\pm} \rangle$.

The experimental approaches to reach the above effects of symmetry shifts (8.16-8.17a) between rotor and antirotor of Bivacuum dipoles (Bivacuum fermions -BVF are the follows:

a) gravitational fields: natural, like generated by the Earth, and the artificial, generated by centripetal acceleration of rotating cylinder or disk;

b) static and saw-shape electric fields. This consequence of our theory is confirmed

experimentally by Townsend Brown electro-gravitational effect. The reduction of increasing the weight of capacitors is dependent on relative position of charged plates. If the positive plate is upside, the weight decreases. If the negative plate is above, the weight of capacitor increases. Later Dan Davidson et al. observed that these gravitational effects increase, if a smaller capacitor is nested under the larger;

- c) static and saw-shape magnetic fields (the Bearden motionless electromagnetic generator (see Kaivarainen, <http://arXiv.org/abs/physics/0207027>, section 14);
- d) rotation magnetic (spin) fields, affecting the gravitational interaction of rotating magnetic system with the Earth; (magneto-gravitational Searl effect, see Kaivarainen, <http://arXiv.org/abs/physics/0207027>, section 13);
- e) the in-phase acceleration of coherent groups of charged particles (electrons or ions) in electric and magnetic fields, like in cyclotron or undulator (see section 6.9 of this paper);
- f) vortices of liquids of the charged molecules, providing the in-phase charges acceleration;
- g) recursive arrays of capacitors providing cumulative Brown effect (Naudin, 2000-2003, Winter, 2003) with cone or pyramid geometry, providing the negative Casimir effect.

It follows from our theory, that the capacitors with some specific shape, like two separated hemispheres, cones or pyramids may provide the negative Casimir effect, i.e. repulsion between two opposite parts of condensers with well conducting internal surface, containing lot of free electrons, like in gold.

I named such capacitors *Virtual Jet Generators (VJG)*, see [Kaivarainen, <http://arXiv.org/abs/physics/0003001>].

The capacitors, prepared from the halves of eggs, with internal surfaces covered with gold film (Dan Winter, <http://www.zayra.de/soulcom/thrust/>) may also have a function of capacitors with negative Casimir effect.

Our Unified model predicts, that the symmetry shift of Bivacuum fermions (dipoles): BVF_{\pm}^{\uparrow} and BVF_{\pm}^{\downarrow} in the Earth gravitational field may be responsible for generation the difference of the electric and gravitational potentials on the opposite sides of asymmetric condensers. *It can be anticipated, that array of [pyramid (cone) + plate] condensers, following the Golden mean rules, will be effective in attempts to get the Gravitational thrust of such a system.* The effectiveness of arrays of such asymmetric condensers, as a source of pure energy, may be elevated by the rotation of platform with such system (see 10.18).

8.7 Generation of unstable groups of coherent photons, electrons and positrons by fields, shifting Bivacuum fermions (dipoles) symmetry

Let us consider the possible results of symmetry shift of virtual *Cooper - like pairs* of Bivacuum fermions (BVF^{\uparrow}) and antifermions (BVF^{\downarrow}) with opposite spins (eq. 5.1), acquiring the opposite mass and charge in gravitational (G), electric (E) and magnetic (H) fields.

The first stage can be considered as clusterization or polymerization of *pairs* of virtual (unstable) sub-elementary particles and antiparticles:

$$[BVF^{\uparrow} \bowtie BVF^{\downarrow}]_{S=0} \equiv [(V^{+\uparrow} V^{-}) \bowtie (V^{+\downarrow} V^{-})]_{S=0} \xrightarrow{\text{G, E, H-fields}} \quad 8.19$$

$$2[BVF^{\uparrow}_+ \bowtie BVF^{\downarrow}_-] \rightleftharpoons 3[BVF^{\uparrow}_+ \bowtie BVF^{\downarrow}_-] \rightleftharpoons n[BVF^{\uparrow}_+ \bowtie BVF^{\downarrow}_-] \quad 8.19a$$

$$\text{or : VirBC} = n[F^{\uparrow}_+ \bowtie F^{\downarrow}_-]^{Vir} \quad (\text{the cluster of } n \text{ virtual pairs}) \quad 8.19b$$

We suppose, that the symmetry shifts in Bivacuum fermions and antifermions are opposite due to exchange spin-spin interaction between them and introduced in this work Bivacuum symmetry compensation principle (section 5.4). As far such Cooper pairs has a virtual bosons properties with zero or integer spins, they may tend to virtual Bose condensation (VirBC) because of very small translational momentums and big de Broglie wave length of pairs $[BVF^{\uparrow}_+ \bowtie BVF^{\downarrow}_-]$:

$$\lambda_{[\mathbf{BVF}_\downarrow \bowtie \mathbf{BVF}_\uparrow]} = h/(m\mathbf{v})_{[\mathbf{BVF}_\downarrow \bowtie \mathbf{BVF}_\uparrow]} \gg L_0 \quad 8.20$$

where $L_0 = \hbar/m_0c$ is the characteristic dimension (radius) of BVF, as a pair of rotor and antirotor.

The second stage of virtual photons, particles and antiparticles origination in asymmetric Bivacuum is dissociation of the big coherent cluster of virtual Bose condensate (8.19b), induced by the gradients of fields potentials, to sextet (virtual photons) and then to triplets (virtual electrons and positrons) of metastable sub-elementary particles:

$$a) \quad \mathbf{n}[\mathbf{F}_\uparrow^+ \bowtie \mathbf{F}_\downarrow^-]^{Vir} \xrightarrow{e^- \text{ and } e^+} \frac{\mathbf{n}}{3} [3\mathbf{F}_\uparrow^+ \bowtie 3\mathbf{F}_\downarrow^-]^{Vir} \equiv \frac{\mathbf{n}}{3} [\text{Virtual photons}] \quad 8.21$$

$$b) \quad \frac{\mathbf{n}}{3} [3\mathbf{F}_\uparrow^+ \bowtie 3\mathbf{F}_\downarrow^-]^{Vir} \xrightarrow{\text{grad}(\mathbf{G}, \mathbf{E}, \mathbf{H})} \frac{\mathbf{n}}{3} \{ \langle [\mathbf{F}_\uparrow^+ \bowtie \mathbf{F}_\downarrow^-] + \mathbf{F}_\downarrow^- \rangle_{Vir}^{e^-} + \langle [\mathbf{F}_\uparrow^+ \bowtie \mathbf{F}_\downarrow^-] + \mathbf{F}_\uparrow^+ \rangle_{Vir}^{e^+} \} \quad 8.21a$$

These metastable (virtual) photons, electrons and positrons may turn to stable ones, if the value of BVF symmetry shifts (8.16-8.17a) will increase to that, corresponding to Golden mean condition, when the resonance energy exchange of sub-elementary particles with Bivacuum in a course of their $[C \rightleftharpoons W]$ pulsation, becomes possible:

$$\Delta \mathbf{m}_C = \mathbf{m}_{\mathbf{BVF}_\pm} = |m_C^+| - |m_C^-| \rightarrow m_0 \quad 8.22$$

$$\text{and : } \mathbf{BVF}_\downarrow^\uparrow \rightarrow \mathbf{F}_\uparrow^+; \quad \mathbf{BVF}_\uparrow^\downarrow \rightarrow \mathbf{F}_\downarrow^- \quad 8.22a$$

However, the dissociation of clusters of metastable photons in state of virtual BC (VirBC) to metastable electrons (e^-) and positrons (e^+) (8.21a) is energetically much easier, than that of stable photons, and may occur even in small fields gradients.

It is important to note, that synchronization of $[C \rightleftharpoons W]$ pulsation of triplets of metastable e^- and e^+ (8.21a), as a condition of quantum entanglement, remains unchanged even after their spatial separation to the two coherent groups (ke^- and ke^+ , where k can be about or more than 10) in magnetic or electric fields or under the influence of virtual spin waves (VirSW), generated by the angular momentum of rotating elementary particles, atoms, molecules and even macroscopic bodies.

Very interesting results, confirming our description of coherent groups of metastable charged particles origination from asymmetric Bivacuum, has been obtained in works of Keith Fredericks (2002)³⁸ and Sue Benford (2001)³⁷.

Fredericks analyzed the trucks on Kodak photo-emulsions, placed in vicinity of human hands during 5-30 minutes. The plastic isolator was used between the fingers and the photographic emulsion. *The results point to existing of correlation in dynamics - twisting of trajectories of big group of charged particles (about 20) in weak magnetic field.* The irregular but in-phase character of set of the trajectories may reflect the influence of geomagnetic flicker noise on the charged particles.

In these experiments the Bivacuum symmetry shift, necessary for metastable particles origination, can be induced by the electric and magnetic potentials around biosystems, including human's body and its fingers. Dissociation of metastable photons and separation of coherent groups of metastable electrons and positrons may occur under the influence of virtual spin waves (VirSW), emitted by microtubules (MTs) of biocells.

The mechanism of VirSW excitation can be explained in the framework of our Hierarchic theory of condensed matter, including the water and ice (see section 1 of this paper). It is related to the fast reversible conversions between primary librational effectons and primary translational effectons (convertons) of water in MTs. The convertons represents 'flickering clusters', i.e. [dissociation \rightleftharpoons association] of coherent water cluster, representing mesoscopic molecular Bose condensate (mBC), accompanied by oscillation of the water molecules angular momentum with the same frequency about 10^7 s^{-1} . If the flickering of water clusters in MTs of the same cell and, even better, between 'tuned' group of cells is in-phase, then the cumulative effect of VirSW

generation by human's finger near photoemulsion can be strong enough for producing the observed tracks.

In work of Sue Benford (2001)³⁷ the special device - *spin field generator* was demonstrated to produce a tracks on the dental film, placed on a distance of 2 cm from generator and exposed to its action for 7 min.

The spin field generator represents rotating hollow cylinder or ring made of ferrite-magnetic material with the axis of rotation coinciding with the cylinder's main symmetry axis. Four permanent (wedge-like) magnets are inserted into the cylinder. It rotates with velocity several thousand revolutions per minute.

The effect of this generator is decreasing with distance and becomes undetectable by the dental films after the distance from the top of cylinder bigger than 8 cm.

The dots and tracks on dental X-ray films were reproduced over 200 trials. They are similar to charged particle tracks on surface emulsions. However, the more exact identification of particles by the experts failed.

The uncommon features of these tracks may be a result of unusual properties of metastable short-living electrons and positrons, presented by (8.21a).

8.8 The experimental program for verification of the proposed fundamental Bivacuum - Mediated Interaction (BMI)

Such a program should include the following directions:

1. Finding a way for increasing the psychic abilities to make the results of experiments more reliable and reproducible (Audio-Video Skin Transmitter: www.karelia.ru/~alexk [see: "Innovations"]);

2. The monitoring of behavior of microtubules in nerve (and other) cells in cells culture and pure system of microtubules 'in vitro' may confirm our conjecture of role of MTs in telepathic contacts and remote healing;

3. Confirmation of data, pointing to ability of crystals for imprinting of Psi- or Biofield and elucidation of mechanism of imprinting (monitoring of water properties);

4. Systematic study of Bivacuum perturbation by biofield, using Casimir attraction between conducting plates and spectral Lamb shift in the same set of experiments;

5. Confirmation of interrelation between the shape of body and properties of virtual replica, generated by this body. For example, influence of the hollow pyramid and cube on water parameters inside them, should be different (pH, conductivity, etc.);

6. Confirmation of consequence of our theory that any dissipative processes, like melting or boiling, are accompanied by replacement of virtual replica of the previous stable phase of condensed matter by the new one and modulation the flicker noise of the resulting virtual replica. This kind of modulation, like generated by psychic, may influence the noise of electronic devices. Consequently, boiling of water near random number generator (RNG) may affect the events probability distribution;

7. The influence of vessel with boiling water on sonoluminescence or spontaneous ultraweak EM radiation of control water in other distant vessel by means of Bivacuum mediated interaction. It should be a confirmation of the influence of Virtual Replica of sender [S] on permittivity and permeability of Bivacuum in receiver [R], changing its intermolecular Van der Waals interaction.

9. Conclusion

Our Unified Model (UM) suggests, that each kind of fields, radiated by triplets $\langle [\mathbf{F}_\uparrow \boxtimes \mathbf{F}_\downarrow] + \mathbf{F}_\uparrow^\pm \rangle^i$, forming elementary particles, is a consequence of corresponding kind of their uncompensated sub-elementary particles \mathbf{F}_\uparrow^\pm dynamics and different contributions to energy of its [W] phase in form of cumulative virtual cloud (CVC):

spin field in form of virtual spin waves in Bivacuum (VirSW), representing oscillation of Bivacuum fermions with opposite spins equilibrium, are excited by spinning of cumulative virtual clouds CVC^\cup or CVC^\cup of [W] phase;

the electromagnetic and gravitational fields are result of modulation of CVC by longitudinal and transversal components of momentum and kinetic energy of $\mathbf{F}_{\uparrow}^{\pm}$ as respect to direction of particle propagation.

The specific *nonlocal virtual wave-guide (VirWG)*, formed by *VirSW*, responsible for targeting in Remote Vision (RV), Remote Healing (RH) and other Psi-phenomena, is supposed to be modulated by the nerve impulse propagation along the axons, depolarization of nerve cells membranes in 'tuned' ensemble of neuron cells. This VirWG, characterized by much bigger internal magnetic field and refraction index, than the external ones ($\mathbf{H}_{in} > \mathbf{H}_{ext}$; $\mathbf{n}_{in} > \mathbf{n}_{ext}$). Such wave-guides of photons is formed by massless virtual spin waves (VirSW), representing dynamic equilibrium of Bivacuum fermions of opposite spins [$\mathbf{BVF}^{\uparrow} \rightleftharpoons \mathbf{BVF}^{\downarrow}$] shift.

VirWG is most sensitive to variations of specific magnetic field, radiated by [Sender] in series of elementary acts of consciousness, perturbing in such a way the local Virtual Replica and quantum neurodynamics of [Receptor]. The Psi-channel between [S] and [R] works better, if the frequency of geomagnetic Schumann waves have the same frequency (around 8 Hz), close to brain waves frequency, is the same in their location, providing better resonance conditions.

Modulation of Schumann waves and other geomagnetic and cosmic flicker noise by low frequency brain waves may participate in synchronization of signals exchange between macroscopic (whole body) and mesoscopic (neurons) systems of [S] and [R]. The virtual wave-guide between [S] and [R], formed by nonlocal VirSW, corresponds to finest tuning in telepathic contact on level of virtual replicas (VR) of coherent clusters of water in state of molecular Bose condensate in microtubules of nerve cells.

The VR, generated by pairs [$\mathbf{F}_{\uparrow}^{-} \otimes \mathbf{F}_{\downarrow}^{+}$] of triplets $\langle [\mathbf{F}_{\uparrow}^{-} \otimes \mathbf{F}_{\downarrow}^{+}] + \mathbf{F}_{\uparrow}^{\pm} \rangle$, forming elementary particles and atoms of matter, can be subdivided to the internal local (VR^{in}) and the external (VR^{ext}) contributions. The *internal - local* contribution of VR^{in} represents all kinds of virtual 3D standing de Broglie waves (VC^{\pm}) in the volume of condensed matter, corresponding to [W] phase of all particles of matter and interactions, mediated by virtual quanta exchange, i.e. from nuclear to intermolecular electromagnetic Van-der Waals interaction.

The overall shape of the total internal virtual replica is a superposition of virtual replicas of its elements is close to shape of body, including the human's one, corresponds to notion of the "ether body (EB)" in Eastern philosophy:

$$EB \equiv VR_{tot}^{in} = \sum VR^{in} \quad 9.1$$

The *external* VR^{ext} contribution has a properties of *quantum hologram*, containing two modulated by matter inseparable components:

1) the *distant* in forms of superposition of Virtual Pressure Waves (VPW^{+} and VPW^{-}) of positive and negative vacuum (VR_{dis}^{ext}), generated by pairs [$\mathbf{F}_{\uparrow}^{-} \otimes \mathbf{F}_{\downarrow}^{+}$] and electromagnetic and gravitational contributions, reflected in longitudinal and transversal vibrations of each of sub-elementary particles of triplets $\langle [\mathbf{F}_{\uparrow}^{-} \otimes \mathbf{F}_{\downarrow}^{+}] + \mathbf{F}_{\uparrow}^{\pm} \rangle$;

2) the *nonlocal* (VR_{nl}^{ext}), related with repulsion/attraction between Bivacuum fermions ($\mathbf{BVF}^{\uparrow\downarrow}$) in virtual wave-guide, provided by Pauli principle and spin-spin exchange interaction, correspondingly.

The superposition of all kind of external virtual replicas may correspond to notion of the "astral body (AB)":

$$AB \equiv VR_{tot}^{ext} = \sum VR_{dis}^{ext} + \sum VR_{nl}^{ext} \quad 9.2$$

The nonlocal and distant VR_{nl}^{ext} and VR_{dis}^{ext} are responsible for the *phase and amplitude* signals transmission between [S] and [R], correspondingly, in the process of Bivacuum mediated interactions.

We may resume now, that our explanation of Mind-Matter (remote vision, remote healing, telekinesis, etc.) and Mind-Matter (telepathy) includes the following 4 stages:

1. 'Targeting' of Receiver [R] by Sender [S] in the process of *remote vision or remote healing* is superposition of their "astral bodies" - distant VR, mediated and spatially directed virtual wave-guide (VirWG), formed by massless standing virtual spin waves (VirSW) with nonlocal properties. Corresponding optimal guide-channel between [S] and [R] is created due to Principle of least action realization (see eq.6.1). The reason of bigger internal refraction index of virtual wave-guide (VirWG) as compared to the external one ($\mathbf{n}_{in} > \mathbf{n}_{ext}$), is a consequence of bigger internal magnetic field, than external one ($\mathbf{H}_{in} > \mathbf{H}_{ext}$). In turn, the excessive internal magnetic field in VirWG is a result of shift of $[\mathbf{B}\mathbf{V}\mathbf{F}^{\uparrow} \rightleftharpoons \mathbf{B}\mathbf{V}\mathbf{F}^{\downarrow}]$ equilibrium to the left or to the right;

2. Synchronization of dynamics of [S] and [R] (macroscopic entanglement) is realized under the influence of Bivacuum Harmonization force (HaF, eq. 5.51a) and spatially coherent geomagnetic flicker noise, determined by fluctuation in Solar system virtual replica (SVR, see eqs. 6.40-6.41 and 6.20c) and Schumann's frequency waves;

3. The nonlocal virtual waveguides (VirWG) with such properties are able to conduct the *information in form of phase (spin)* of sub-elementary particles of triplets $\langle [\mathbf{F}_{\uparrow}^- \otimes \mathbf{F}_{\downarrow}^+] + \mathbf{F}_{\uparrow}^{\pm} \rangle$ and the *energy in form of virtual photons* between [S] and [R]. The Faraday cage can not screen such a mechanism of EM energy transmission-tunnelling. The energy exchange between virtual replicas of Sender and Receiver: $\mathbf{V}\mathbf{R}_S \rightleftharpoons \mathbf{V}\mathbf{R}_R$ can be provided also by uncompensated pressure $\Delta\mathbf{V}\mathbf{P}^{\pm} = \mathbf{V}\mathbf{P}^+ - \mathbf{V}\mathbf{P}^-$ of virtual pressure waves ($\mathbf{V}\mathbf{P}\mathbf{W}^+$ and $\mathbf{V}\mathbf{P}\mathbf{W}^-$), excited by the in-phase $[\mathbf{C} \rightleftharpoons \mathbf{W}]$ pulsation of pairs $[\mathbf{F}_{\uparrow}^- \otimes \mathbf{F}_{\downarrow}^+]$. The informational/phase exchange between [S] and [R] can be a result of partial superposition: $[\mathbf{V}\mathbf{R}_S \approx \mathbf{V}\mathbf{R}_R]^{Hol}$, representing hologram-like virtual 3D standing waves (see eqs. 5.1-5.3). The *remote vision* can be explained by such mechanism of informational exchange;

4. The active information and energy exchange, between [S] and [R], dependent on intention, like telepathy and remote healing, can be a consequence of modulation of $\mathbf{V}\mathbf{R}_{tot}^{in}$ and $\mathbf{V}\mathbf{R}_{tot}^{ext}$ of [Sender] and virtual wave-guide (VirWG) between [S] and [R] by selective electromagnetic activity of nerve system and brain of [S].

The following parameters of corresponding signals can be Sender intention dependent:

a) the phase/spin of VirSW, transmitting the information via virtual wave-guide $[\mathbf{V}\mathbf{R}\mathbf{W}\mathbf{G}_S \approx \mathbf{V}\mathbf{R}\mathbf{W}\mathbf{G}_R]$;

b) the amplitude of signals, i.e. density of energy of virtual photons channelling via virtual wave-guide $[\mathbf{S} \approx \mathbf{R}]$ and value of excessive virtual pressure $\Delta\mathbf{V}\mathbf{P}^{\pm} = \mathbf{V}\mathbf{P}^+ - \mathbf{V}\mathbf{P}^-$. The EM energy of virtual photons is dependent on the fraction of coherent electrons in the nerve system cells of [S]. The value of $\Delta\mathbf{V}\mathbf{P}^{\pm}$ is related directly to fraction of coherent water molecules in the nerve cells of [S] and [R], 'tuned' to each other via guide $[\mathbf{S} \approx \mathbf{R}]$ and $[\mathbf{V}\mathbf{R}_S \approx \mathbf{V}\mathbf{R}_R]^{Hol}$. The excessive virtual pressure exchange may influence the dielectric permeability (ϵ) and permittivity (μ) of Bivacuum and internal virtual replicas $\mathbf{V}\mathbf{R}_{tot}^{in}$ of [S] and [R], changing the van der Waals interactions between water molecules and probability of cavitation fluctuations.

This probability is related with probability of **gel** \rightleftharpoons **sol** transitions in nerve cells bodies and redistribution of synaptic contacts, representing in accordance to our model the elementary act of consciousness (see Chapter 4 of this paper).

Such a mechanism can provide *telepathic contact* between [S] and [R]. The mechanism of remote healing could be the same, but the local targets in the body of patient [R] should be not necessarily the MTs of nerve cells, but MTs or other microfilaments (i.e. actin fibers) in cells of the ill organs, which also have their 'ether body' and can be targeted by healer.

Each elementary particle, atom and molecule may have own characteristic virtual replica with properties of Quantum hologram. The same is true for coherent clusters of atoms/molecules in quantum state of [mBC]. The [mBC] may exist in macromolecules, like proteins, DNA, membranes, water, chromosomes, bones and any other kind of condensed matter. The $\mathbf{V}\mathbf{R}^{ext}$ of *complex systems* represents the hierarchy of $\mathbf{V}\mathbf{R}^{ext}$ of their *subsystems*, *very sensitive to oscillation of Bivacuum symmetry shift with frequencies, close to resonant ones*.

The superposition of $\mathbf{V}\mathbf{P}\mathbf{W}_{Bv}^{\pm}$ of Bivacuum and $\mathbf{V}\mathbf{P}\mathbf{W}_{M}^{\pm}$, generated by matter, forming ($\mathbf{V}\mathbf{R}_{dis}^{ext}$),

has a properties of virtual quantum hologram. The *primary* modulation of VPW_{Bv}^{\pm} by matter is a result of superposition of $(VC^{\pm})_{Bv}$ with virtual clouds $(VC^{\pm})_{M}$, emitted and absorbed in a course of $[C \rightleftharpoons W]$ pulsation of symmetric pairs $[\mathbf{F}_{\uparrow}^{-} \bowtie \mathbf{F}_{\downarrow}^{+}]$ of elementary particles of Matter with frequency, close to that of Golden mean:

$$\omega_{C \rightleftharpoons W}^{\phi} = \omega_{VPW_{Bv}^{\pm}} = \omega_0 = m_0 c^2 / \hbar$$

For the regular e -electron the frequency of $[C \rightleftharpoons W]$ pulsation is $\omega_0^e \simeq 9 \cdot 10^{21} s^{-1}$.

In turn, the *secondary* modulation of pulsation frequency $\omega_{C \rightleftharpoons W}$ and VPW^{\pm} occur with frequency (Ω) of *coherent vibrations* (translations, librations) of atoms and molecules of matter, much lower, than that of VPW^{\pm} . The high frequency coherent VPW_{Bv}^{\pm} of Bivacuum may play the role of the pilot waves in quantum hologram (VR_{dis}^{ext}) of matter. *The modulated by matter virtual pressure waves VPW^{+} and VPW^{-} are responsible for the distant component of (VR_{dis}^{ext}) of [S] and [R].*

The notion of nonlocal Universe Virtual Replica (UVR) is introduced, as superposition of all material replicas of the Universe, including living organisms. The possible subtle influence of human's cumulative VR in some special states on the Universe VR (UVR) in bifurcation points of UVR self-organization, means possibility of the active role of human's consciousness in evolution of the Universe. *The possibility of UVR to self-organization is a consequence of nonequilibrium active medium of Bivacuum, composed from double cells - dipoles, the active elements.* Unification of the evolution of humans consciousness (including their brains and bodies) with evolution of Universe Virtual Replica occur under the permanent influence of Harmonization force (HaF) of Bivacuum, driving Superconsciousness, as a Quantum Supercomputer, to Golden Mean conditions.

One of possible applications of Unified model is related to conclusion, that so called 'free energy' is a result of virtual Bivacuum fermions (dipoles) symmetry shift by gravitational, electric and/or magnetic fields, making the mass and charge of these asymmetric dipoles nonzero. The antigravitation effect (which can be used also as a source of pure energy) can be achieved by the certain superposition of artificial gravitation, generated by centripetal acceleration, strong permanent magnetic and electric fields of corresponding arrays/system of asymmetric condensers. The artificial antigravitation in fact, means generation of the opposite Bivacuum symmetry shift to that, characteristic to natural gravitation.

10 Abbreviations and Definitions, Introduced in Unified Model of Matter - Fields Duality & Bivacuum Mediated Interactions*

- (\mathbf{V}^{+}) and (\mathbf{V}^{-}) are correlated actual rotor and complementary antirotor of Bivacuum, formed by subquantum particles of the opposite quantized energy, virtual mass, spin, charge and magnetic moments, separated by energetic gap (see p.29);

- $(\mathbf{BVF}^{\uparrow} = \mathbf{V}^{+} \uparrow\uparrow \mathbf{V}^{-})^i$ and $(\mathbf{BVF}^{\downarrow} = \mathbf{V}^{+} \downarrow\downarrow \mathbf{V}^{-})^i$ are cells-dipoles, named Bivacuum fermions and Bivacuum antifermions. Their opposite half integer spins $S = \pm \frac{1}{2} \hbar$, notated as (\uparrow and \downarrow), depend on direction of clockwise or anticlockwise rotation of pairs of [rotor (\mathbf{V}^{+}) + antirotor (\mathbf{V}^{-})], forming them (see p.30);

- $(\mathbf{BVB}^{\pm} = \mathbf{V}^{+} \updownarrow \mathbf{V}^{-})^i$ are Bivacuum bosons, representing the intermediate transition state between \mathbf{BVF}^{\uparrow} and $\mathbf{BVF}^{\downarrow}$ (see p.30). The index: $i = e, \mu, \tau$ define the energy and other properties of three lepton generations;

- $(\mathbf{VC}_{j,k}^{+} \sim V_j^{+} - V_k^{+})^i$ and $(\mathbf{VC}_{j,k}^{-} \sim V_j^{-} - V_k^{-})^i$ are virtual clouds and anticlouds, composed from sub-quantum particles. Virtual clouds and anticlouds emission/absorption accompany the correlated transitions between different excitation states (j, k) of rotors $(V_{j,k}^{+})^i$ and antirotors $(V_{j,k}^{-})^i$ of Bivacuum dipoles $[\mathbf{BVF}^{\uparrow}]^i$ and $[\mathbf{BVB}^{\pm}]^i$. *Virtual particles and antiparticles* in our model are the result of certain superpositions of virtual clouds: $\mathbf{VC}_{j,k}^{+}$ and $\mathbf{VC}_{j,k}^{-}$ (see p.30);

- \mathbf{VP}^\pm is *virtual pressure*, resulted from the process of [creation \rightleftharpoons annihilation] of virtual clouds ($\mathbf{VC}_{j,k}^\pm$) (see p.30-31);
- \mathbf{VPW}^+ and \mathbf{VPW}^- are the *positive and negative virtual pressure waves*, related with oscillations of (\mathbf{VP}^\pm); (see p.30);
- $\Delta\mathbf{VP}^\pm = |\mathbf{VP}^+ - \mathbf{VP}^-| \sim |\mathbf{VPW}^+ - \mathbf{VPW}^-| \sim |\mathbf{VC}_{j,k}^+ - \mathbf{VC}_{j,k}^-|_{S=0} \geq 0$ means the excessive virtual pressure, being the consequence of secondary Bivacuum asymmetry (see p. 30);
- \mathbf{F}_\uparrow^+ and \mathbf{F}_\uparrow^- are sub-elementary *fermions and antifermions* of the opposite charge (+/-) and energy. They emerge due to stable symmetry shift between the *actual* (V^+) and *complementary* (V^-) rotors of \mathbf{BVF}^\dagger cells-dipoles: [$\mathbf{BVF}^\dagger \rightarrow \mathbf{F}_\uparrow^\pm$] to the regions of positive or negative energy of Bivacuum dipoles, correspondingly. Their stability is determined by the resonant exchange interaction with Bivacuum in the process of [**Corpuscle** \rightleftharpoons **Wave**] pulsations (see p.32);
- $\langle [\mathbf{F}_\uparrow^- \bowtie \mathbf{F}_\uparrow^+] + \mathbf{F}_\uparrow^\pm \rangle^{e^+}$ is the coherent triplet of two sub-elementary fermions and one sub-elementary antifermion, representing the positron (see p.32);
- $\langle [\mathbf{F}_\uparrow^+ \bowtie \mathbf{F}_\uparrow^-] + \mathbf{F}_\uparrow^\pm \rangle^{e^-}$ is the coherent triplet of two sub-elementary antifermions and one sub-elementary fermion, representing the electron. The absolute values of energy of sub-elementary particles/antiparticles in both triplets are equal and determined presumably by energy of *uncompensated* [\mathbf{F}_\uparrow^\pm] (see p.32);
- (**CVC**) is *cumulative virtual cloud* of sub-quantum particles, representing [**W**] phase of sub-elementary particles, pulsating between the Corpuscular [**C**] and the Wave [**W**] phase: [**C** \rightleftharpoons **W**]. These reversible high-frequency quantum beats are accompanied by [emission \rightleftharpoons absorption] of **CVC** (see p.37);
- $\phi = (\mathbf{v}^2/c^2)^{ext, in} = 0.6180339887$ is a **Golden mean** (see p. 39);
- **VirBC** is *virtual Bose condensation* of Cooper - like pairs [$\mathbf{BVF}^\dagger \bowtie \mathbf{BVF}^\dagger$] and [\mathbf{BVB}^\pm], providing the nonlocal properties of Bivacuum domains (see p.47). These domains represent multilayer structure. Each of 2D layer is formed by pairs [$\mathbf{BVF}^\dagger \bowtie \mathbf{BVF}^\dagger$] with defects, created by [\mathbf{BVB}^\pm];
- **HaE** and **HaF** are *Harmonization Energy and Harmonization Force* of secondary Bivacuum, correspondingly, driving the matter to Golden Mean conditions and responsible for its evolution on all hierarchic levels (see p. 48);
- **VirSW** are *Virtual spin waves*, excited by the angular moments of cumulative virtual clouds (CVC) of sub-elementary particles in triplets $\langle [\mathbf{F}_\uparrow^- \bowtie \mathbf{F}_\uparrow^+] + \mathbf{F}_\uparrow^\pm \rangle$. They are highly anisotropic, depending on orientation (polarization) of triplets in space (see p. 50);
- **VirWG** are the *nonlocal virtual wave-guides* of virtual and real photons, formed by **VirSW**. The internal magnetic field and refraction index of **VirWG** are much higher than the external ones: $\mathbf{H}_{in} \gg \mathbf{H}_{ext}$; $n_{in} > n_{ext}$ (see p. 50);
- (**mBC**) means *mesoscopic molecular Bose condensate*, representing, for example, the coherent fraction of water in *microtubules* (**MT**) of neurons. It plays the important role in Bivacuum mediated Mind-Matter and Mind-Mind interaction in accordance to our theory (see p.60);
- **VR** is the *Virtual Replica (phantom)* of elementary, particles, atoms, molecules, matter and its different forms, including living organisms, created as a result of perturbation of Bivacuum by electromagnetic and gravitational contributions of the energy of each of sub-elementary particles of pairs [$\mathbf{F}_\uparrow^- \bowtie \mathbf{F}_\uparrow^+$] of triplets $\langle [\mathbf{F}_\uparrow^- \bowtie \mathbf{F}_\uparrow^+] + \mathbf{F}_\uparrow^\pm \rangle$. This perturbation is a result of \mathbf{F}_\uparrow^- and \mathbf{F}_\uparrow^+ of pairs in-phase [**C** \rightleftharpoons **W**] pulsation, accompanied by the exchange interaction with Bivacuum (see p.52);
- (**EVR**) is the Earth **VR** (see p.62);
- (**SVR**) is a Star (Sun, in private case) system Virtual Replica (p.68);
- **SSC** is a star system consciousness (p.67);
- **GVR** is the Galactical Virtual Replica, resulting from superposition of its all **SVR** (see p. 67);
- [**SC(t)**] is a Superconsciousness, originating from superposition of all Virtual Replicas of the Universe. The (**SC**) could be considered, as a Quantum Supercomputer, acting as a

self-organizing and evolving hierarchical hologram-like system in both time directions (future and past) (see p.67);

- **BMI** is the new fundamental Bivacuum Mediated Interaction, including electromagnetic, gravitational, weak, strong and nonlocal interactions between different kinds of quantum coherent systems (see p.76).

**The abbreviations are not in alphabetic, but in logical order to make this glossary more useful for perception of new notions, introduced in this work.*

REFERENCES

1. Kaiväräinen A., Theory of condensed state as a Hierarchical system of quasiparticles formed by phonons and three-dimensional de Broglie waves of molecules. Application of the theory for description of thermodynamic properties of water and ice. J. Mol. Liquids, 41, 53 (1989).
2. Kaivarainen A., Book: Hierarchic concept of matter and field. Water, biosystems and elementary particles. New York, NY, pp. 482, ISBN 0-9642557-0-7 (1995); New Hierarchic theory of water and its role in biosystems. The quantum Psi problem. Proceedings of the International conference: "Energy and informational transfer in biological systems: How physics could enrich biological understanding". F. Musumeci, L.S. Brishik, M.W. Ho (editors), World Scientific, pp. 82-147, (2003); http://www.karelia.ru/~alexk/new_articles/index.html
3. Kaivarainen A., Hierarchic theory of condensed matter and its computerized application to water and ice. Archives of Los-Alamos: <http://arXiv.org/abs/physics/0102086>, (2001).
4. Eisenberg D., Kauzmann W., The structure and properties of water. Oxford University Press, Oxford, (1969).
5. Kaivarainen A., Solvent-dependent flexibility of proteins and principles of their function. D.Reidel Publ.Co., Dordrecht, Boston, Lancaster, (1985).
6. Kaivarainen A., Mechanism of antifreeze proteins action, based on Hierarchic theory of water and new "clusterphilic" interaction. Archives of Los-Alamos: <http://arXiv.org/abs/physics/0105067>, (2000).
7. Kaivarainen A., Hierarchic theory of matter, general for liquids and solids: ice, water and phase transitions. American Institute of Physics Conference Proceedings, **573**, 181 (2001).
8. Clegg J.S. and Drost-Hansen W. On the biochemistry and cell physiology of water. In: Hochachka and Mommsen (eds.). Biochemistry and molecular biology of fishes. Elsevier Science Publ. **1**, Ch.1, 1 (1991).
9. Dicke R.H. Coherence in spontaneous radiation processes. Phys.Rev. **93**, 99 (1954).
10. Kaivarainen A., Hierarchic model of consciousness: from molecular Bose condensation to synaptic reorganization. Archives of Los-Alamos: <http://arXiv.org/abs/physics/0003045> (2000).
11. Kaivarainen A., CASYS: Hierarchic model of consciousness: from molecular Bose condensation to synaptic reorganization. International Journal of Computing Anticipatory Systems. **10**, 322-338, (2001).
12. Hameroff S. Proceedings of 2nd Annual advanced water science symposium. Dallas, Texas, USA (1996).
13. Hameroff S.R. and Penrose R. In: Toward a Science of Consciousness - Tucson I, S. Hameroff, a. Kaszniak and A.Scott (eds.). MIT Press, Cambridge, MA. 507 (1996).

14. Singer W. *Annu. Rev. Physiol.*, 55, 349 (1993).
15. Albrecht-Buehler G. *J. Cell Biol.*, **114**, 493 (1991).
16. Albrecht-Buehler G. Rudimentary form of cellular "vision". *Proc. Natl. Acad. Sci. USA*, **89**, 8288 (1992).
17. Kaivarainen A., *CASYS: International Journal of Computing Anticipatory Systems*, **10**, 121 (2001); Unified Model of Bivacuum, Particles Duality, Electromagnetism, Gravitation & Time. Archives of Los-Alamos <http://arXiv.org/abs/physics/0207027>, (2002).
18. S. Savva *MISAAH Issue 24-27*, February (2000).
19. Puthoff H. and Targ R. Direct Perception of Remote Geographical Locations. In *The Iceland Papers*, A. Puharich, Editor, 1979. Republished by The Planetary Association for Clean Energy, Ottawa, Canada, 17 (1996).
20. Benor, D. *Healing Research*, Vol.1, Helix, UK, 366 (1992).
21. Sidorov, L. (2001) On the Possible Mechanism of Intent in Paranormal Phenomena. *Journal of Theoretics*, July (2001); (URL www.journaloftheoretics.com/Links/links-papers.htm); *JNLRMI* 1 (1) January 2002 (URL www.emergentmind.org/sidorov_I.htm)
22. Sidorov, L. (2002) The Imprinting and Transmission of Mentally-Directed Bioinformation. *JNLRMI* 1(1) January 2002; (URL: www.emergentmind.org/sidorov_II.htm)
23. Nakamura, H., Kokubo, H., Parkhomtchouk, D., Chen, W., Tanaka, M., Zhang, T., Kokado, T., Yamamoto, M. and Fukuda, N. Biophoton and temperature changes of human hand during Qigong. *Journal of ISLIS* 18(2) September (2000).
24. Oschman, J.L. The Electromagnetic Environment: Implications for Bodywork. Part I: Environmental Energies. *Journal of Bodywork and Movement Therapies* **4** (1) 56 January (2000).
25. Parkhomov A.G. Experiments and thoughts. In book: *Physicist in parapsychology. Essays. "Hatrol"*, Moscow, 2002, p.15-38.
26. Dulnev G.N. Registration of phenomena of psychokinesis by means of magnetic devices. In book: *Physicist in parapsychology. Essays. "Hatrol"*, Moscow, 2002, p.48-51.
27. Adamenko A.A., Levchuk Yu.N. The use of the microbiological sensor for the biogenesis fields investigations. *Parapsychology and psychophysics*, 1994, v14, N 2, p. 34-41 (in Russian).
28. Korotaev S.M., Serdyuk V.O., Sorokin M.O., Abramov J.M. Geophysical manifestation of interaction of the processes through the active properties of time // *Physics and Chemistry of the Earth*. A. 1999. v. 24. №8. p. 735-740.
29. Korotaev S.M., Serdyuk V.O. and Sorokin M.O. Manifestation of macroscopic nonlocality in the geomagnetic and solar-ionospheric processes. *Geomagnetism and Aeronomy*. 2000, v.40. №3, pp. 56-64, (in Russian).
30. Korotaev S.M., Serdyuk V.O. and Sorokin M.O. Experimental verification of Kozyrev's interaction of natural processes // *Galilean Electrodynamics*. 2000, v.11. S.I. 2. pp. 23-29.
31. Tiller W.A., Dibble W.E., Jr. and Kohane M.J. *Conscious Acts of Creation: The emergence of a new physics*. Pavior Publishing, Walnut Creek, CA, USA (2001).
32. Campbell T. *My Big Toe: A trilogy unifying philosophy, physics and metaphysics*, 2003; <http://www.My-Big-TOE.com>.
33. Korotkov K.G., Registration of biofield influence on a gas-discharge detector. In book: *Physicist in parapsychology. Essays. "Hatrol"*, Moscow, 2002, pp. 44-47.
34. Narimanov A.A. On the pyramid form effects. *Biophysics*, 2001, N5, p. 951-957 (in Russian).

35. Miakin S.V. The influence of the pyramid on the matter objects. Consciousness and physical reality, 2002, N2, p. 45-53.
36. Shnoll S.E. The form of the macroscopic fluctuation spectra depends on the Earth rotation. Biophysics, 1995, N 4, p. 865-874; Shnoll S.E., Zenchenko T.A., Zenchenko K.I., Pozharskii V.A., Kolombet V.A., Kondradov A.A. Regular variation of the fine structure of statistical distributions as a consequence of cosmophysical agents. Uspekhi Fizicheskikh Nauk, Russian Acad. Sci. 2000, v.43 (2), p. 205-209.
37. Benford M.S. Probable axion detection via consistent radiographic finding after exposure to a Shpilman axion generator. J. Theoretics, vol.4-1, 2002.
38. Fredericks K., The photographic detection of tachyons in human body radiation. Journal of Nonlocality and Remote Mental Interaction, 2002.
39. Germiné M. Scientific validation of planetary consciousness. Journal of Nonlocality and Remote Mental Interaction, v.I, Nr. 3, 2002; www.emergentmind.org/germineI3.htm
40. Stapp H.P. Mind, matter and quantum mechanics. New York: Springer-Verlag.
41. Gariaev P.P., Tertishny G.G., Iarochenko A.M., Maximenko V.V., Leonova E.A. The spectroscopy of biophotons in non-local genetic regulation. Journal of Nonlocality and Remote Mental Interaction, v.I, Nr. 3, 2002; www.emergentmind.org/gariaevI3.htm
42. Winter D. Research Proposal. <http://www.zayra.de/soulcom/thrust/>